

**DEVELOPMENT OF HIGH EARLY-STRENGTH CONCRETE FOR  
ACCELERATED BRIDGE CONSTRUCTION CLOSURE POUR  
CONNECTIONS**

**Dr. Sergio F. Breña, PI  
Dr. Scott A. Civjan, Co PI  
Stephanie Castine, Graduate Student Assistant  
Gercelino Ramos, Graduate Student Assistant**

**Prepared for  
The New England Transportation Consortium  
December 2018  
NETCR115                      No. 13-1**

This report, prepared in cooperation with the New England Transportation Consortium, does not constitute a standard, specification, or regulation. The contents of this report reflect the views of the authors who are responsible for the facts and the accuracy of the data presented herein. The contents do not necessarily reflect the views of the New England Transportation Consortium or the Federal Highway Administration.

## **Acknowledgements**

The following are the members of the Technical Committee that developed the scope of the work for the project and provided technical oversight throughout the course of the research:

Maura Sullivan, Massachusetts DOT, Chairperson  
Daniel John, New Hampshire DOT  
Christopher Hart, Rhode Island DOT  
Ali Jamalipour, Connecticut DOT  
Jose Lima, Rhode Island DOT  
Michael Redmond, Maine DOT  
Robert Young, Vermont Agency of Transportation

**Technical Report Documentation Page**

1. Report No. NETCR115	2. Government Accession No. N/A	3. Recipient's Catalog No. N/A	
4. Title and Subtitle  <i>Development of High Early-Strength Concrete for Accelerated Bridge Construction Closure Pour Connections</i>		5. Report Date December 2018	
		6. Performing Organization Code N/A	
7. Author(s) Sergio F. Breña, Scott A. Civjan, Stephanie L. Castine, Gercelino Ramos		8. Performing Organization Report No. NETCR115	
9. Performing Organization Name and Address University of Massachusetts Amherst 130 Natural Resources Rd, Marston Hall 233 Amherst, MA, 01003		10. Work Unit No. (TRAIS) N/A	
		11. Contract or Grant No. N/A	
12. Sponsoring Agency Name and Address New England Transportation Consortium C/O Transportation Research Center University of Vermont, Farrell Hall 210 Colchester Avenue Burlington, VT 05405		13. Type of Report and Period Covered Final Report	
		14. Sponsoring Agency Code NETC 13-1. A study conducted in cooperation with the U.S. DOT	
15. Supplementary Notes N/A			
16. Abstract  Accelerated bridge construction (ABC) has become a popular alternative to using traditional construction techniques in new bridge construction and existing bridge deck replacement because of the reduction of time spent in field activities. A key feature of bridges built using ABC techniques is the extensive use of prefabricated components. Prefabricated components are joined in the field using small volume closure pours involving high performance materials (steel and concrete) to ensure adequate transfer of forces between components. To date, the materials developed for closure pours have been based on proprietary components, so a need has arisen for development of mixes that use generic components. The goal of this research was to create a method to develop concrete mixtures that are designed using generic constituents and that satisfy performance requirements of accelerated bridge construction closure pours in New England, primarily high early strength and long-term durability. Two concrete mixtures were developed with a primary goal of reaching high-early strength while maintaining constructability. The secondary goal of the concrete mixtures was to be durable; therefore, measures were taken during the development of the concrete mixture to generate a mixture that also had durable properties.			
17. Key Words  <b>ACCELERATED BRIDGE CONSTRUCTION, CLOSURE POURS, HIGH EARLY STRENGTH CONCRETE</b>		18. Distribution Statement  No restriction. This document is available to the public through the National Technical Information Service, Springfield, Virginia 22161	
19. Security Classif. (of this report) Unclassified	20. Security Classif. (of this page) Unclassified	21. No. of Pages 211	22. Price N/A

<b>SI* (MODERN METRIC) CONVERSION FACTORS</b>				
<b>APPROXIMATE CONVERSIONS TO SI UNITS</b>				
<b>SYMBOL</b>	<b>WHEN YOU KNOW</b>	<b>MULTIPLY BY</b>	<b>TO FIND</b>	<b>SYMBOL</b>
<b>LENGTH</b>				
in	inches	25.4	millimeters	mm
ft	feet	0.305	meters	m
yd	yards	0.914	meters	m
mi	miles	1.61	kilometers	km
<b>AREA</b>				
in <sup>2</sup>	square inches	645.2	square millimeters	mm <sup>2</sup>
ft <sup>2</sup>	square feet	0.093	square meters	m <sup>2</sup>
yd <sup>2</sup>	square yard	0.836	square meters	m <sup>2</sup>
ac	acres	0.405	hectares	ha
mi <sup>2</sup>	square miles	2.59	square kilometers	km <sup>2</sup>
<b>VOLUME</b>				
fl oz	fluid ounces	29.57	milliliters	mL
gal	gallons	3.785	liters	L
ft <sup>3</sup>	cubic feet	0.028	cubic meters	m <sup>3</sup>
yd <sup>3</sup>	cubic yards	0.765	cubic meters	m <sup>3</sup>
NOTE: volumes greater than 1000 L shall be shown in m <sup>3</sup>				
<b>MASS</b>				
oz	ounces	28.35	grams	g
lb	pounds	0.454	kilograms	kg
T	short tons (2000 lb)	0.907	megagrams (or "metric ton")	Mg (or "t")
<b>TEMPERATURE (exact degrees)</b>				
°F	Fahrenheit	5 (F-32)/9 or (F-32)/1.8	Celsius	°C
<b>ILLUMINATION</b>				
fc	foot-candles	10.76	lux	lx
fl	foot-Lamberts	3.426	candela/m <sup>2</sup>	cd/m <sup>2</sup>
<b>FORCE and PRESSURE or STRESS</b>				
lbf	poundforce	4.45	newtons	N
lbf/in <sup>2</sup>	poundforce per square inch	6.89	kilopascals	kPa
<b>APPROXIMATE CONVERSIONS FROM SI UNITS</b>				
<b>SYMBOL</b>	<b>WHEN YOU KNOW</b>	<b>MULTIPLY BY</b>	<b>TO FIND</b>	<b>SYMBOL</b>
<b>LENGTH</b>				
mm	millimeters	0.039	inches	in
m	meters	3.28	feet	ft
m	meters	1.09	yards	yd
km	kilometers	0.621	miles	mi
<b>AREA</b>				
mm <sup>2</sup>	square millimeters	0.0016	square inches	in <sup>2</sup>
m <sup>2</sup>	square meters	10.764	square feet	ft <sup>2</sup>
m <sup>2</sup>	square meters	1.195	square yards	yd <sup>2</sup>
ha	hectares	2.47	acres	ac
km <sup>2</sup>	square kilometers	0.386	square miles	mi <sup>2</sup>
<b>VOLUME</b>				
mL	milliliters	0.034	fluid ounces	fl oz
L	liters	0.264	gallons	gal
m <sup>3</sup>	cubic meters	35.314	cubic feet	ft <sup>3</sup>
m <sup>3</sup>	cubic meters	1.307	cubic yards	yd <sup>3</sup>
<b>MASS</b>				
g	grams	0.035	ounces	oz
kg	kilograms	2.202	pounds	lb
Mg (or "t")	megagrams (or "metric ton")	1.103	short tons (2000 lb)	T
<b>TEMPERATURE (exact degrees)</b>				
°C	Celsius	1.8C+32	Fahrenheit	°F
<b>ILLUMINATION</b>				
lx	lux	0.0929	foot-candles	fc
cd/m <sup>2</sup>	candela/m <sup>2</sup>	0.2919	foot-Lamberts	fl
<b>FORCE and PRESSURE or STRESS</b>				
N	newtons	0.225	poundforce	lbf
kPa	kilopascals	0.145	poundforce per square inch	lbf/in <sup>2</sup>

\*SI is the symbol for the International System of Units. Appropriate rounding should be made to comply with Section 4 of ASTM E380.

## **Abstract**

Accelerated bridge construction (ABC) has become a popular alternative to using traditional construction techniques in new bridge construction and existing bridge deck replacement because of the reduction of time spent in field activities. A key feature of bridges built using ABC techniques is the extensive use of prefabricated components. Prefabricated components are joined in the field using small volume closure pours involving high performance materials (steel and concrete) to ensure adequate transfer of forces between components. To date, the materials developed for closure pours have been based on proprietary components, so a need has arisen for development of mixes that use generic components. The goal of this research was to create a method to develop concrete mixtures that are designed using generic constituents and that satisfy performance requirements of accelerated bridge construction closure pours in New England, primarily high early strength and long-term durability. Two concrete mixtures were developed with a primary goal of reaching high-early strength while maintaining constructability. The secondary goal of the concrete mixtures was to be durable; therefore, measures were taken during the development of the concrete mixture to generate a mixture that also had durable properties.

## TABLE OF CONTENTS

Abstract.....	v
TABLE OF CONTENTS.....	vi
LIST OF TABLES.....	ix
LIST OF FIGURES .....	xi
1 INTRODUCTION.....	1
1.1 Motivation for Study.....	1
1.2 Research Objective.....	4
1.3 Scope of Work.....	5
2 BACKGROUND.....	7
2.1 Literature Review.....	7
2.1.1 Hydraulic Cements.....	7
2.1.2 Aggregates.....	8
2.1.3 Additional Cementitious Materials.....	15
2.1.4 Chemical Admixtures.....	18
2.1.5 Proportioning.....	21
2.1.6 Curing Conditions.....	23
2.2 State of Practice.....	23
2.2.1 State of Practice Mix Designs.....	24
2.2.2 Key Performance Features of ABC Closure Concrete (from survey) 26	
3 DEVELOPMENT OF CONCRETE MIXTURE DESIGN.....	27
3.1 Methodology.....	27
3.1.1 Trial Batches.....	28
3.1.2 Additional Short-term Testing.....	29
3.1.3 Long-term Testing.....	32
3.2 Materials.....	32
3.2.1 Aggregates.....	32
3.2.2 Cementitious Materials.....	34
3.2.3 Chemical Admixtures.....	35
3.3 Proportioning.....	36

	3.3.1	Replication of State-of-Practice Concrete Mixtures .....	36
	3.3.2	ACI 211.4 Guidelines Report Method .....	37
	3.3.1	Maximum Compaction of Aggregates .....	39
4		LABORATORY TESTING AND PROCEDURES .....	65
	4.1	Preparation and Storage of Materials .....	65
	4.2	Mixing Procedure .....	66
	4.3	Aggregate Testing Procedures.....	69
	4.3.1	Gradation Curves.....	70
	4.3.2	Bulk Density and Voids .....	70
	4.3.3	Density, Relative Density and Absorption .....	71
	4.4	High Range Water Reducing Admixture Dosage Analysis .....	71
	4.5	Concrete Testing Procedures.....	74
	4.5.1	Strength .....	74
	4.5.2	Constructability .....	75
	4.5.1	Durability .....	80
5		RESULTS OF CONCRETE MIXTURE TESTING .....	106
	5.1	Strength .....	106
	5.1.1	Compressive Strength .....	106
	5.2	Constructability .....	112
	5.2.1	Slump/Spread .....	112
	5.2.2	Set Time .....	119
	5.3	Additional Testing.....	121
	5.3.1	Air Content.....	121
	5.3.2	Bar Pullout .....	123
	5.3.3	Confined Shrinkage.....	129
	5.3.4	Alkali Silica Reactivity .....	144
	5.3.5	Freeze-Thaw Durability .....	145
6		LARGE-SCALE LABORATORY TESTS .....	150
	6.1	Overview .....	150
	6.2	Specimen Design.....	150
	6.3	Specimen Fabrication .....	153

6.3.1	Panel Fabrication.....	153
6.3.1	Joint Construction .....	155
6.4	Test Set Up.....	157
6.5	Design Strength.....	159
6.6	Testing.....	161
6.7	Test Results .....	162
7	CONCLUSIONS .....	168
7.1	Recommendations for Concrete Specification .....	173
APPENDIX A	.....	180
APPENDIX B	.....	183
APPENDIX C	.....	189
APPENDIX D	.....	194



## LIST OF TABLES

Table	Page
Table 2-1: Compilation of State-of-Practice Concrete Mixtures used for Accelerated Bridge Construction Closure Pours in New England .....	25
Table 2-2: Key Performance Features of ABC Closure Pour Concrete Collected Compiled from Surveys.....	26
Table 3-1: Short-term Tests Performed at Trial Batch Stage.....	29
Table 3-2: Short-term Tests Performed on Developed Concrete Mixture .....	29
Table 3-3: Long-term Tests Prepared to Run on Developed Concrete Mixture .....	32
Table 3-4: Concrete Mixture Trial Batch Developed Using ACI 211.4R Guideline.....	39
Table 3-5: Trial Batch Concrete Mixtures Developed using the Maximum Compaction of Aggregates Method with Reported Compressive Strengths and Consistency of Concrete .....	62
Table 3-6: Trial Batch Mixtures Measuring the Effects of HRWR Dosage and Increased Curing Temperature on the Selected Mixture Designs .....	64
Table 4-1: Sieve Sizes Chosen for Determining Aggregate Gradation .....	70
Table 4-2: Mortar Batch Mix Designs Used for ASR Testing.....	88
Table 5-1: Comparison of Average Compressive Strength Values with Varying w/cm Ratios	108
Table 5-2: Comparison of Average Compressive Strength Values with Varying $V_{paste}/V_{voids}$ Ratios .....	109
Table 5-3: Comparison of Average Compressive Strength Values with Varying Coarse Aggregate Size .....	110
Table 5-4: Compressive Strength Values for Selected Concrete Mixtures.....	111
Table 5-5: Slump and Spread Values for Selected Concrete Mixtures.....	114
Table 5-6: Air Content of Two Selected Mixtures with and without HRWR Dosage Change .	123
Table 5-7: Bar Pullout Test Specimen Labels and Results .....	124
Table 5-8: Normal Concrete Mix Design Used for Confined Shrinkage Test.....	130

Table 5-9: Summary of Confined Shrinkage Specimen Parameters.....	132
Table 5-10: Summary of Freeze-Thaw Results – Prism 1-Set A.....	147
Table 5-11: Summary of Freeze-Thaw Results – Prism 2-Set A.....	148
Table 5-12: Summary of Freeze-Thaw Results – Prism 1-Set B .....	148
Table 5-13: Summary of Freeze-Thaw Results – Prism 2-Set B .....	149
Table 6-1: Summary of Specimen Capacity .....	161
Table 6-2: Compressive Strength Measured from Cylinder Tests.....	161
Table 6-3: Calculated Capacity and Experimental Failure Load Comparison.....	167
Table A-1: Summary of Source 1 and Source 2 Coarse and Fine Aggregate Properties.....	182
Table B-1: Trial Batch Concrete Mixture Design Quantities per Cubic Yard of Concrete (MIX 1 – MIX 4) .....	183
Table B-2: Trial Batch Concrete Mixture Design Quantities per Cubic Yard of Concrete Cont. (MIX 5 – MIX 7) .....	184
Table B-3: Trial Batch Concrete Mixture Design Quantities per Cubic Yard of Concrete Cont. (MIX 7A – MIX 9) .....	185
Table B-4: Trial Batch Concrete Mixture Design Quantities per Cubic Yard of Concrete Cont. (MIX 10 – MIX 12) .....	186
Table B-5: Trial Batch Concrete Mixture Design Quantities per Cubic Yard of Concrete Cont. (MIX 13 – MIX 15) .....	187
Table B-6: Trial Batch Concrete Mixture Design Quantities per Cubic Yard of Concrete Cont. (MIX 15-HD – MIX 18) .....	188
Table C-1: Results from Compressive Strength Tests of Concrete Mixtures .....	189
Table C-2: Results from Compressive Strength Tests of Concrete Mixtures (Cont.).....	190
Table C-3: Air Content Measured in Concrete Mixtures.....	191
Table C-4: Slump and Spread Measured in Concrete Mixtures .....	192
Table C-5: Slump and Spread Measured in Concrete Mixtures (Cont.) .....	193
Table D-1: ABC Closure Pour Concrete Mix Design Recommendations .....	195
Table D-2: ABC Closure Pour Concrete Specifications .....	196

## LIST OF FIGURES

Figure	Page
Figure 1-1: Closure pours in a Massachusetts precast bulb-tee bridge using UHPC (pictures courtesy of S. Brena) .....	2
Figure 2-1: Schematic of Weak Interfacial Transition Zone Forming Pathway (Shane et al. 2000) .....	11
Figure 2-2: Schematic Representations of Different Aggregate Gradations and Corresponding Gradation Curves (Young et al. 1998).....	12
Figure 2-3: Schematic Description of Concepts of Dense Gradation (Young et al., 1998).....	13
Figure 2-4: Fuller-Thompson Maximum Density (Minimum Void Content) Gradation Curves (Young et al. 1998) .....	14
Figure 2-5: Power .45 Curves Used for Maximum Aggregate Density.....	15
Figure 2-6: Strength and Permeability as a Function of W/CM (Hover and Stokes 1995) .....	21
Figure 2-7: Cylinders of Concrete Made with Increasing Paste Volume from Left to Right (Taylor et al. 2015) .....	22
Figure 3-1: Flowchart of Experimental Testing Procedure.....	31
Figure 3-2: Source 1 Aggregates. From Left to Right: 3/4” Coarse Aggregate, 1/2” Coarse Aggregate, Fine Aggregate .....	33
Figure 3-3: Source 2 Aggregates. From Left to Right: 3/4” Coarse Aggregate, 1/2” Coarse Aggregate, 3/8” Coarse Aggregate, Fine Aggregate.....	33
Figure 3-4: Compressive Strength vs. HRWR (Superplasticizer) Dosage as a Percentage of Cementitious Materials by Mass for W/C = 0.3 (Han et al. 2013) .....	38
Figure 3-5: Recommended w/cm Ratios Provided by ACI 211.4R.....	40
Figure 3-6: 1/2” Coarse Aggregate in Combination with Fine Aggregate Gradation Curves Plotted Against 1/2” Maximum Compaction Fuller Thompson Curves .....	43
Figure 3-7: Correlation Between Fuller-Thompson Curves and One Coarse Size Aggregate (1/2” and 3/8”) .....	43
Figure 3-8: 3/8” Coarse Aggregate in Combination with Fine Aggregate Gradation Curves Plotted Against 3/8” Maximum Compaction Fuller Thompson Curves .....	45

Figure 3-9: Correlation between Fuller-Thompson Curves and Two Coarse Size Aggregate (1/2” and 3/8”) .....	45
Figure 3-10: 1/2” Maximum Aggregate Size Gradation Curves Plotted Against 1/2” Maximum Compaction Fuller Thompson Curves .....	46
Figure 3-11: Gap Gradation Analysis of the Optimal Maximum Aggregate Compaction Gradation Curve for Each Coarse Aggregate Size Evaluated.....	47
Figure 3-12: HRWR Dosage Effects on the Workability of Concrete.....	51
Figure 3-13: MIX 1 Thick Consistency Shown in Wheelbarrow and in Compression Strength Molds .....	54
Figure 3-14: MIX 11 in Wheelbarrow Showing Segregation with Thin Paste on Top and Aggregates Being Scooped up from the Bottom .....	55
Figure 3-15: Concrete Mix with Acceptable Consistency .....	57
Figure 4-1: Measured Concrete Constituents Before Mixing .....	68
Figure 4-2: Removal of Concrete from the Machine Mixer in Preparation for Testing and Casting .....	69
Figure 4-3: Concrete Batch in Machine Mixer during Rest Period with the Plastic Cover .....	69
Figure 4-4: Concrete Hand-Mixed for HRWR Dosage Analysis Small-Scale Trial Batches.....	72
Figure 4-5: Slump Test Setup Performed on the Small-Scale Trial Batches for the HRWR Dosage Analysis .....	73
Figure 4-6: Slump Measurement Being Taken on Concrete Containing a HRWR Dosage of 16 oz./cwt.....	73
Figure 4-7: Cylindrical Mold .....	75
Figure 4-8: Measuring the Slump of a Concrete Mixture .....	76
Figure 4-9: Lifting of Spread Test Mold and Measuring of the Resulting Circular Spread of Concrete .....	77
Figure 4-10: Acme Penetrometer Used to Measure Initial and Final Set Time of Concrete Mixtures & Various Penetrometer Needle Sizes .....	78
Figure 4-11: Sieving Coarse Aggregates out of Concrete to Form Mortar for Set Time Test.....	79
Figure 4-12: Plastic Cylindrical Mold Cut to be used for Set Time Penetrometer Tests.....	79
Figure 4-13: Water Injected Through Petcock of Type-B Meter for Air Content Test .....	80
Figure 4-14: Formwork for Shrinkage Ring Test Setup .....	82

Figure 4-15: Bonded Strain Gauge to Steel Ring for Shrinkage Test.....	83
Figure 4-16: Wet Curing of the Top Surface of the Shrinkage Rings using Prewetted Burlap and Plastic Covering.....	83
Figure 4-17: Micro Measurements P3 Strain Indicator and Recorder, Version 2.11 Used to Record Strains During the Shrinkage Test.....	85
Figure 4-18: Required Gradation of Aggregates Used in Alkali-Silica Reactivity Testing as Specified by ASTM C1567.....	87
Figure 4-19: Gradation of Source 2 Fine Aggregate and Stone Dust Compared to Required Aggregate Gradation for Use in ASR Test.....	87
Figure 4-20: Hand Mixing the Mortar for ASR Testing.....	89
Figure 4-21: Mortar Cast into Molds for ASR Testing.....	89
Figure 4-22: ASR Specimens Submerged in Sodium Hydroxide Solution.....	91
Figure 4-23: ASR Specimens Drying on Rags before Taking Length Change Measurements ...	92
Figure 4-24: Length Comparator Shown Being Zeroed on Left and Taking a Reading of an ASR Specimen on Right.....	92
Figure 4-25: Prisms used for Freeze-Thaw Testing.....	93
Figure 4-26: Schematic of Bar Pullout Test Reinforcement for No.4 Test Bar.....	96
Figure 4-27: Schematic of Bar Pullout Test Reinforcement for No.6 Test Bar.....	97
Figure 4-28: Formwork and Steel Reinforcement Schematic for Bar Pullout Test Specimens Using a No. 4 Test Bar.....	98
Figure 4-29: Apparatus Used for Measuring Slip During Bar Pullout Test.....	100
Figure 4-30: Top View of Test Apparatus Schematic.....	102
Figure 4-31: Side View of Test Apparatus Schematic.....	103
Figure 4-32: Bar Pullout Test Apparatus.....	104
Figure 5-1: Strength Gain Curves of Trial Batch and Selected Concrete Mixtures (Light to Dark).....	107
Figure 5-2: Compressive Strength Curves of Selected Concrete Mixtures.....	110
Figure 5-3: Example of MIX 6-HD with Stiff Consistency.....	113
Figure 5-4: Example of MIX 6-HD with Flowable Consistency.....	113

Figure 5-5: Example of MIX 15-HD with Stiff Consistency.....	115
Figure 5-6: Example of MIX 15-HD with Flowable Consistency.....	116
Figure 5-7: Temperature and Relative Humidity Recordings at Time of Mixing Versus Spread and Slump Readings of the Selected Concrete Mixtures.....	116
Figure 5-8: Spread and Slump Readings of Concrete Mixtures .....	118
Figure 5-9: Set Time Penetration Tests Performed on Trial Batch and Selected Concrete Mixtures .....	120
Figure 5-10: Air Content of Trial Batch and Selected Concrete Mixtures .....	122
Figure 5-11: Typical Failure of Bar Pullout Tests with No.4 Test Bar.....	126
Figure 5-12: Concrete Cracking in Bar Pullout Tests with No.4 Test Bar .....	126
Figure 5-13: Load versus Displacement Plots for Bar Pullout Specimens Containing No.6 Test Bars .....	127
Figure 5-14: Concrete Cracking of Test Specimen 6-HD-6 .....	128
Figure 5-15: Concrete Cracking of Test Specimen 15-HD-6 .....	129
Figure 5-16: Confined Shrinkage Test Results for MIX 6-HD, Including Time to Cracking, Strain versus Time and 12-Hour Compressive Strength .....	131
Figure 5-17: Confined Shrinkage Test Results for MIX 15-HD, Including Time to Cracking, Strain versus Time and 12-Hour Compressive Strength.....	135
Figure 5-18: Typical Crack Formation in a Confined Shrinkage Ring.....	137
Figure 5-19: Shrinkage Cracking Occurring as One Crack in a Confined Shrinkage Ring.....	138
Figure 5-20: Shrinkage Cracking Occurring as Two Cracks in a Confined Shrinkage Ring ....	138
Figure 5-21: Crack Widths of MIX 6-HD Confined Shrinkage Specimens Plotted with Change in Strain that Occurred at Cracking.....	139
Figure 5-22: Crack Widths of MIX 6-HD Confined Shrinkage Specimens Plotted with Change in Strain that Occurred at Cracking.....	140
Figure 5-23: Confined Shrinkage Test Results for Normal Concrete, Including Time to Cracking Strain versus Time .....	142
Figure 5-24: Ring Shrinkage Test Results of Normal Concrete and High Performance Concrete with and without Shrinkage Reducing Admixture (See et al. 2003).....	143
Figure 5-25: Expansion Alkali Silica Reactivity Test Specimens .....	145

Figure 5-26: Condition of Sets of Prisms after 36 Cycles of Freeze-Thaw Testing .....	146
Figure 6-1: Details of Specimen 1: (a) Elevation View of Test Specimen; (b) Joint Detail.....	152
Figure 6-2: Details of Specimen 2: (a) Elevation View of Test Specimen; (b) Joint Detail.....	152
Figure 6-3: Specimen 1 Reinforcement: (a) Plan View of Test Specimen; (b) Joint Detail.....	153
Figure 6-4: Details of Specimen 2: (a) Plan View of Test Specimen; (b) Joint Detail .....	154
Figure 6-5: Panel Fabrication: (a) Formwork and Reinforcement; (b) Casting; (c) Cured Panels .....	156
Figure 6-6: Joint Construction: (a) Panels Positioning (b) Concrete Casting (c) Finished Surface and Side View of Joint.....	158
Figure 6-7: Schematic of the Specimen Test Set Up .....	158
Figure 6-8: Test Set Up.....	159
Figure 6-9: Test Specimen Force Application Diagram and Shear and Moment Diagrams.....	160
Figure 6-10: Crack in the Joint: Specimen 1 (left); Specimen 2 (right).....	163
Figure 6-11: Hairline Flexural Cracks in the Panels: Specimen 1 (left); Specimen 2 (right) ...	164
Figure 6-12: Crack Propagation: Specimen 1 (left); Specimen 2 (right) .....	164
Figure 6-13: Concrete Crushing: Specimen 1 (left); Specimen 2 (right).....	164
Figure 6-14: Top View after Failure: Specimen 1 (left); Specimen 2 (right) .....	165
Figure 6-15: Detail View (Front) of the Joint after Failure: Specimen 1(left); Specimen 2 (right) .....	165
Figure 6-16: Detail View (Back) of the Joint after Failure: Specimen 1 (left); Specimen 2 (right) .....	165
Figure 6-17: Load-Deflection Plot from Specimen 1 Test .....	166
Figure 6-18: Load-Deflection Plot from Specimen 2 Test .....	167
Figure A-0-1: 1/2” Aggregate Gradation Curves of Source 1 and Source 2 Aggregates .....	180
Figure A-0-2: 3/4” Aggregate Gradation Curves of Source 1 and Source 2 Aggregates .....	180
Figure A-0-3: 3/8” Aggregate Gradation Curves of Source 2 Aggregates .....	181
Figure A-0-4: Fine Aggregate Gradation Curves of Source 1 and Source 2 Aggregates .....	181

# 1 INTRODUCTION

## 1.1 Motivation for Study

Accelerated bridge construction (ABC) is a construction technique that has become popular with existing bridge deck replacement and even with some new bridge construction projects because of the reduction in on-site activities. By reducing the on-site activities, ABC techniques reduce the overall construction time, which results in economic savings. ABC techniques also create safer roadway conditions and reduce traffic delays when compared to traditional construction techniques.

One common technology used with ABC is prefabricated bridge elements and systems. When this technology is utilized for ABC, structural components of the bridge are built offsite or adjacent to the alignment. When the structural components of the bridge are prefabricated, they can be fabricated concurrently with other construction activities and shipped to the site. This is unlike traditional construction methods, where structural members are constructed on site sequentially (i.e. the pier columns and caps must be built before the beams and decks are placed, etc.). The prefabricated structural members are the components of ABC technology which allows for a reduction in construction time and cost (Beerman 2016). Prefabricated components are joined on site with small volume closure pours using high performance materials, commonly comprised of steel and concrete. Concrete closure pours must ensure adequate load transfer between structural components before the bridge is in use by developing high strengths in a short period of time.

Currently, most materials used for closure pours contain proprietary components, such as ultra-high performance concrete (UHPC) that contains steel fibers, or rapid setting concrete that contains proprietary cements (Ultimax Cement, Rapid Set DOT Cement, etc.). The proprietary nature of these materials makes it difficult to specify in federally funded projects making their use



sparse and only on selected projects. Research has been conducted by the Federal Highway Administration (FHWA), the American Concrete Institute (ACI) and the New Jersey Department of Transportation (NJDOT) that demonstrates UHPC and rapid setting concrete can successfully meet the demands required of connections between prefabricated components (Al-manaseer et al. 2000; Balaguru and Bhatt 2001; Najm and Balaguru 2005; Russell and Graybeal 2013). Rapid setting concrete mixtures have shown to reach 2000 psi (14 MPa) in as little as 3 hours. UHPC has displayed a range of ultimate strengths from 20 to 30 ksi (140 to 200 MPa). An example of an UHPC in a recently constructed bulb-tee bridge in Massachusetts can be seen in Figure 1-1.

As mentioned, the materials currently used for ABC closure pours utilize properties of proprietary components, making it expensive for extensive use and hindering the widespread application of these materials. It is also difficult to sole-source proprietary materials in state bridge projects, which often makes it impractical to specify these materials for ABC.



Figure 1-1: Closure pours in a Massachusetts precast bulb-tee bridge using UHPC (pictures courtesy of S. Brena)

Consequently, a need for the development of concrete mixtures comprised of generic components

has emerged. These concrete mixtures must still satisfy some of the performance requirements of ABC closure pours, including a high strength gain rate and long-term durability for their use in highway bridge projects.

Most of the past research on UHPC and rapid setting concrete has not incorporated the working and environmental conditions specific to New England (Najm and Balaguru 2005; Russell and Graybeal 2013). During both construction and operation, bridges in New England are subjected to unique demands. The very wide range in temperatures that are encountered need to be considered for construction; temperatures in New England range from highs above 90°F in the summer to lows near 0°F in the winter. Even if measures are taken to avoid casting concrete for closure pours in extreme temperatures, a wide range of temperatures need to be accommodated for concrete mixtures with intended use in New England. Temperature at the time of placement affects short-term and long-term concrete properties, including set time, strength gain rate, ultimate strength, plastic shrinkage, drying shrinkage and workability. During the winter, bridges are also subjected to freeze-thaw cycles and the use of deicing chemicals, both of which could negatively affect the durability of the concrete used for closure pours.

The rate at which concrete gains strength is fundamental for concrete to successfully be used for closure pours in ABC. If the high-early strength properties are satisfied with generic components, there are other concrete properties that may be impaired by the high cement contents that high-early strength concrete might have as part of its mix design. One property of high-early strength concrete that may be of concern is the workability, measured by its set time and slump. The slump and set time are typically reduced with high-early strength concrete mixtures. This is especially an area of concern when the concrete is placed in warm temperatures. Advice has been provided to yield a longer window of workability with a greater slump based on the results of prior research (Balaguru and Bhatt 2001; Najm and Balaguru 2005). It is advised to keep concrete mixing until time of placing; movement helps to maintain workability. Retarding admixtures have

also been useful to create a longer period of workability, but should be used with caution because they may reduce early strength gains.

High-early strength concrete is also more susceptible to plastic and drying shrinkage than normal concrete (Najm and Balaguru 2005). The presence of cracking in closure pour concrete is especially problematic for bridges in New England because cracking will increase the effects of freeze-thaw damage and the penetration of deicing chemicals, which can lead to premature deterioration and structural deficiency of bridges (Zhuang 2009).

There are various methods to mitigate shrinkage cracking in concrete; these methods will be considered when developing a high-early strength concrete for closure pour use. One method used to decrease shrinkage cracking is the addition of a shrinkage reducing admixture (SRA). The benefits as well as the disadvantages of SRA are later discussed in Section 2.1.4.2. Another method used to reduce shrinking is the addition of fly ash. Concrete containing fly ash does not have an increased tensile strength, but does have lower internal stresses caused by shrinkage, as later explained in Section 2.1.3.1.

The broader use of ABC construction techniques in bridge projects in New England therefore relies on the development of non-proprietary concrete mixtures that meet performance requirements of closure pours and can withstand the construction and operational conditions that are particular to the regional environment.

## **1.2 Research Objective**

The main objective of this research project was to develop and validate concrete mixtures that develop high-early strength without detrimentally affecting their long-term performance. The concrete mixtures designed for this research project were developed for use in ABC in New England; therefore, attention was paid to conditions specific to the environment in the region

when developing the mixtures, such as freeze-thaw cycles, the use of deicing materials and concrete placement under a varied range of temperatures.

### **1.3 Scope of Work**

The concrete mixtures developed in this research project have a primary goal of achieving high-early strength while maintaining constructability. The concrete mixtures were designed to achieve a compressive strength of 4000 psi in 12 hours. This strength development was defined in consultation with the project technical committee and the PCI-NE Bridge Technical Committee. The constructability of the concrete was evaluated qualitatively by the ability to cast the concrete into common molds used for various material tests, and by measuring slump or spread tests depending on mix flowability, and through set time tests. Trial batches were modified through an iterative process, as described in section 3.1, until desired strength and constructability goals were met.

The secondary goal of the concrete developed in this research project was for it to be durable. Measures were taken during the development of the concrete mixture design to generate a mixture that also had durable properties. Once concrete mixtures achieved the primary strength and constructability goals, two mixtures were selected for further testing. The two selected mixtures were tested for air content, shrinkage, bond strength of reinforcement with concrete, and alkali-silica reactivity. The test results were analyzed and reported in Section 5.

In addition to characterizing the material properties of the high early-strength concrete mixture developed as part of this project, large-scale laboratory tests were conducted with the goal of gaining insight into the constructability and strength of the material in conditions that are more representative of a field application. One of the two selected mixtures was used in a longitudinal closure pour of two large-scale slabs that simulate the connection between two precast bridge deck panels. The specimens were tested one day after casting the closure pour to

determine if the selected mixture the connection is capable of developing high strength and ensure adequate transfer of forces between two structural components in a short period of time.

Freeze-thaw and chloride permeability test is recommended to be performed to further analyze the durability of the selected concrete mixtures. Because of the long-term nature of these tests and/or the need for specialized equipment, freeze-thaw testing has not been completed and chloride permeability test will not be performed as part of this project.

The research project activities initiated with a literature review that summarizes technical articles and reports related to this research area. A survey was conducted to document the current experience of personnel in DOTs and other transportation agencies within the New England region on the use of high-early strength concrete in previous transportation projects. The state of practice and key performance features required of ABC closure pour concrete was identified through this survey as well.

Based on all test results, the literature review and the survey responses, a mixture design specification was developed that provides the characteristics of the mix required to meet the desired performance of the concrete. This specification will directly provide requirements to develop future concrete mixtures (including testing) to ensure adequate strength development, constructability and durability required of ABC closure pour concretes.

## 2 BACKGROUND

### 2.1 Literature Review

A literature review was performed on each of the constituents that will be considered in the development of the high-early strength concrete mixture designs.

#### 2.1.1 Hydraulic Cements

Several studies have investigated the effect of cement type on of high-early strength development in concrete. Many cements that are used to produce a high-early strength concrete mixture are proprietary, such as Ultimax Cement and CTS Cement. The compressive strength of concrete containing Ultimax Cement was determined to be 20 to 40% higher than concrete containing ASTM Type I/II Cement, without chemical or mineral admixtures being added to any mix (Al-manaseer et al. 2000). Other proprietary cement types have shown similar effects on strength gain of concrete (Balaguru and Bhatt 2001). The objective of this research is to develop a mix using non-proprietary materials; therefore, the use of these proprietary cements was not considered an option.

Non-proprietary cement considered for this project were ASTM Type I, I/II, II and III. While ASTM Type I/II cement is the most widely used and available, ASTM Type III cement is high early strength so it seemed the most appropriate for the requirements of high early strength development in this project. ASTM Type III cement has shown to have the most significant strength gain increase at 1 day and earlier, compared to other non-proprietary cements (Freyne et al. 2004). During this study Freyne et al. also found that ASTM Type III cement reached the highest splitting tensile strength of the non-proprietary cements tested in their research. The early strength development of ASTM Type III cement has been attributed to a greater fineness of particles, which often exceeds 500 m<sup>2</sup>surface area per kg of cement (500 m<sup>2</sup>/kg). The increased fineness of cement means results in a higher surface area of cement particles that interact with

mixing water in the concrete mixture compared with normal strength cement (ASTM Type I/II). The larger surface area has a direct effect on the rate at which cement hydrates, predominantly during the early period of hydration, and therefore, the rate at which strength is gained (ACI Committee E-701 2013). Accordingly, ASTM Type III was the hydraulic cement type selected for this research project.

### **2.1.2 Aggregates**

Aggregate properties significantly affect the workability of fresh concrete, as well as the strength, durability, density and thermal properties of hardened concrete. The following sections discuss these effects.

#### ***2.1.2.1 Aggregate Texture and Aggregate Shape***

The texture of aggregates is a property that alters the workability of and strength of concrete mixtures. Surface texture of aggregates refers to the degree of irregularity or roughness of the aggregate particle surface. Terms such as rough or granular are used to define aggregate particles that have a large amount of irregularity in their surface. Alternatively, smooth or glassy are used to describe aggregate particles with very little surface irregularity. Studies have shown that there are benefits of both types of surface textures, depending of the desired properties of a concrete mixture. Smooth particles require less mixing water, and therefore require less cementitious material at a fixed  $w/cm$  ratio and workability of concrete. One of the functions of water in a fluid concrete mixture is to lubricate aggregate surfaces so aggregates with smooth surfaces require less lubrication to result in a workable mixture compared with aggregates having surface irregularities. The ability to use less cementitious material is an economical advantage; thus, the use of smooth aggregates is often a cost-efficient option. Using aggregates with rough surfaces have a strength benefit over using aggregates with smooth surfaces. This is due to the

larger bonding area rough aggregate surfaces have with cement paste in comparison with smooth aggregate surfaces (ACI Committee E-701 1999).

The shape of aggregates is another property that contributes to the workability of fresh concrete as well as the strength of hardened concrete. Rounded aggregates, such as a natural river stone, are best in terms of the workability of concrete. The higher the sphericity of a particle, the lower the surface area and, therefore, the lower the demand for mixing water in concrete to yield the same workability. Aggregates with angular shape, such as crushed stone, are best to develop higher strength concrete compared with spherical aggregates. (ACI Committee E-701 1999; Taylor et al. 2015)

#### ***2.1.2.2 Aggregate Size***

The maximum aggregate size has a strong impact on the strength of concrete. The main reason for this is attributed to the change in bond strength between coarse aggregates and cement paste with different aggregate sizes (Xie et al. 2012). There is contradictory information that can be found regarding the optimal maximum coarse aggregate size. There have been studies showing that concrete containing larger coarse aggregate sizes are stronger, and that coarse aggregates should be graded up to the maximum size that is practical based on constructability considerations (Transportation Research Board 2013; Xie et al. 2012). Other resources indicate that smaller maximum coarse aggregate sizes increase the strength of concrete (ACI Committee 211 2008; ACI Committee E-701 1999; Koehler and Fowler 2007). Although there is discrepancy about the optimal maximum aggregate size, there is agreement on the strong correlation between maximum aggregate size and bond strength between coarse aggregates and cement paste.

The bond strength between paste and aggregates, which develops at the interfacial transition zones, is not as high as the cement paste or aggregates alone. The interfacial transition zone is the portion of the cement paste that surrounds each aggregate within concrete. Generally,



the interfacial transition zone is less dense than the bulk hydrated zone (non-interfacial transition zone) of the cement paste. The size difference between the cement particles and aggregates is significant in the transition zone forming a “wall effect”, which has been identified as the main source for the transition zone weakness. The “wall effect” causes there to be a surplus of water and a deficiency of cement particles near the aggregate surface, relative to the bulk hydrated cement paste. Due to this deficiency in the interfacial transition zone of concrete, a weak point forms in the concrete and provides a preferable pathway for the ingress of potentially harmful chloride ions, as shown in Figure 2-1 (Byard and Ries 2011). The two arguments that can be made regarding the optimal maximum coarse aggregate size are the following: (1) by having larger coarse aggregates, the number of interfacial transition zones decrease, so larger coarse aggregates result in higher strength concrete (Xie et al. 2012); and (2) stresses generated at the interfacial transition zone are greater with larger coarse aggregate because of the greater size difference between the cement particles and aggregates, so using smaller coarse aggregates results in higher concrete strength (ACI Committee E-701 1999). Because of the discrepancy in these arguments, trial batches were performed with different maximum coarse aggregate sizes to determine the optimal size that resulted in maximum strength of the concrete mixtures for this project.

The use of larger coarse aggregates decreases demand for cement paste within a concrete mixture. The decrease of cement paste will decrease shrinkage and provide a stronger interlock in pavement joints. Thus, maximum coarse aggregate size should be considered when the desire is to control plastic shrinkage (Transportation Research Board 2013).

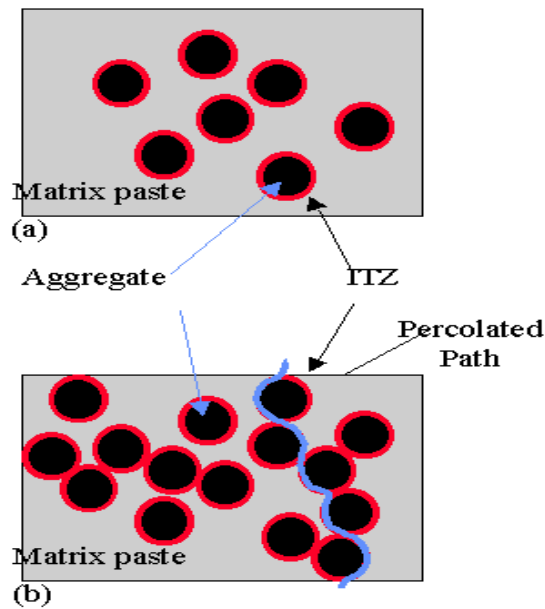

Figure 2-1: Schematic of Weak Interfacial Transition Zone Forming Pathway (Shane et al. 2000)

The maximum aggregate size is also limited by the application of the concrete. The coarse aggregates need to be small enough that bridging does not occur during consolidation and they need to be able to fit around reinforcement, wire mesh, ducts, etc. when concrete is being placed. Guidelines for choosing maximum coarse aggregate size for high-strength concrete can be found in ACI 211.4R (ACI Committee 211 2008; Transportation Research Board 2013).

### 2.1.2.3 Aggregate Gradation

Although the particle size distribution or gradation of aggregates within concrete have been proven to affect the workability and strength of concrete, a universally optimal gradation has not yet been established. There are several types of aggregate gradations. In general, continuously graded aggregate and gradations with high packing densities are favorable to develop high strength concrete (Koehler and Fowler 2006; Young et al. 1998). Gap gradations often result in a concrete with a more fluid consistency, which means less high-range water reducing (HRWR) admixture is required for a desired workability. Gap gradation can also be beneficial to concrete strength because it can help reach high packing density (Koehler 2014). However, extreme gap

gradation should be avoided, especially with large maximum coarse aggregate sizes, because it can lead to segregation between the cement paste and coarse aggregates. Schematic and gradation curves for continuous, uniform and gap-graded aggregates can be seen Figure 2-2.

One way to ensure that gap gradation is avoided and a relatively uniform gradation is reached is by setting limits within the percent retained chart, which is defined in ASTM C136: *Sieve Analysis of Fine and Coarse Aggregate*. The percent of aggregates retained on any two consecutive sieves is greater than 10% and less than 35% of the total aggregates (Koehler 2014).

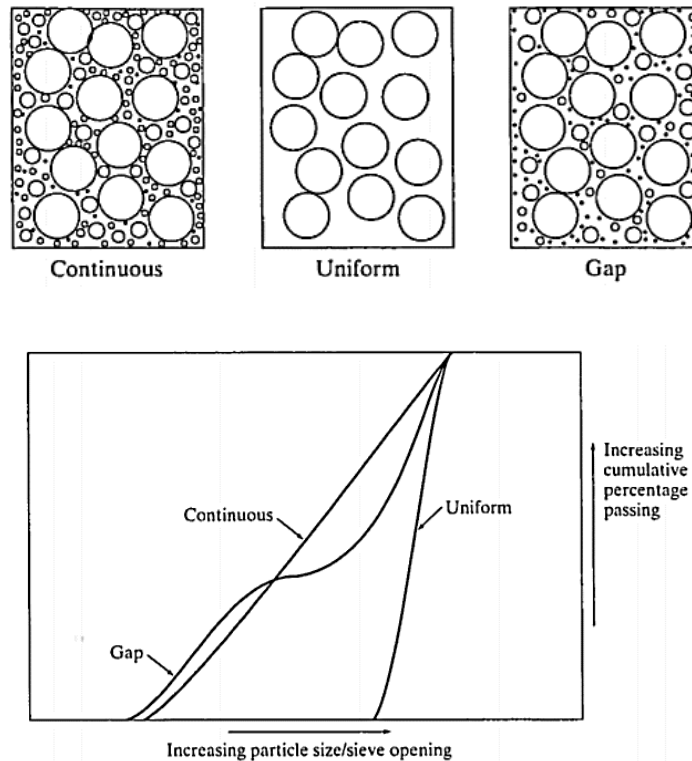

Figure 2-2: Schematic Representations of Different Aggregate Gradations and Corresponding Gradation Curves (Young et al. 1998)

One method to determining maximum density aggregate gradation is by using the Fuller-Thompson maximum density (minimum void content) gradation curves (Young et al. 1998). This method provides gradation curves for each maximum aggregate size that will produce the greatest density, as shown in Figure 2-4.

A schematic depicting the concept of dense gradation can be found in Figure 2-3. To use this method, the proportion of fine aggregate to coarse aggregate is modified to best fit the appropriate curve for the maximum aggregate size. Aggregates that are typically obtained commercially from an aggregate source (quarry) may not conform to these gradation curves; therefore, two or more aggregates with different gradation curves may have to be blended to obtain these results. There has also been some criticism of this method; stating that the parabolic gradations simply do not work and there needs to be a certain proportion of fine aggregate for workability purposes (Mindess and Young 1981).

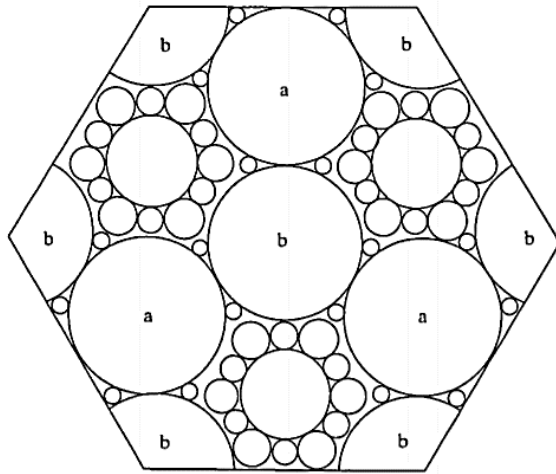

Figure 2-3: Schematic Description of Concepts of Dense Gradation (Young et al., 1998)

Another method (a modified version of the Fuller-Thompson curves) used for determining maximum aggregate compaction is the Power .45 Curve. This method was developed by The Bureau of Public Roads (now the Federal Highway Administration) and published in a report titled *Aggregate Gradation for Highways*. The power .45 curve is formed on a plot of percent passing versus size where the aggregate sizes are raised to the 0.45 power. A straight line is drawn between the No. 200 sieve (the smallest sieve size) and the maximum aggregate size sieve. This straight line is the maximum density gradation for this method. To reach maximum packing of aggregates, the gradation curve should be at the .45 power curve or finer (Koehler

2014). A plot showing power .45 curves for various maximum aggregate sizes can be seen in Figure 2-5.

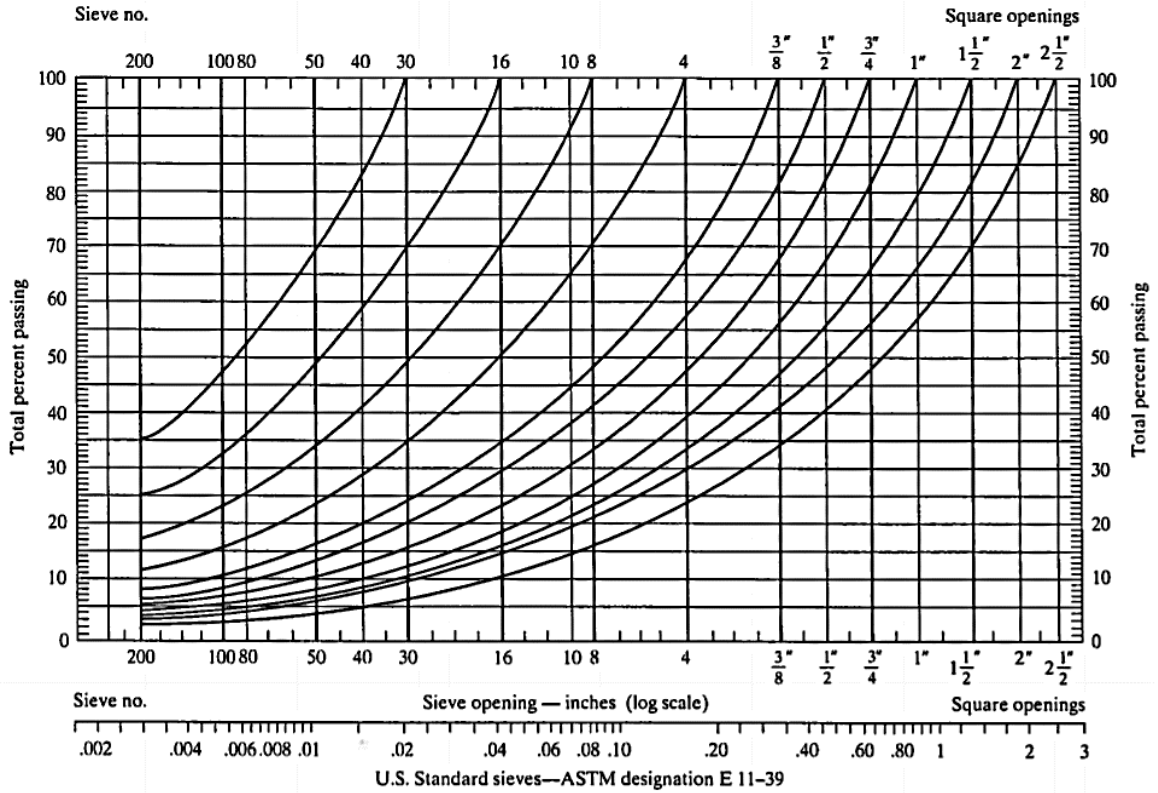

Figure 2-4: Fuller-Thompson Maximum Density (Minimum Void Content) Gradation Curves (Young et al. 1998)

As mentioned, maximum aggregate compaction or maximum density of aggregates is recognized as a favorable gradation, but these methods do not necessarily provide the optimal aggregate gradation. Trial batches are needed to determine the optimal gradation for a specific concrete mixture and application.

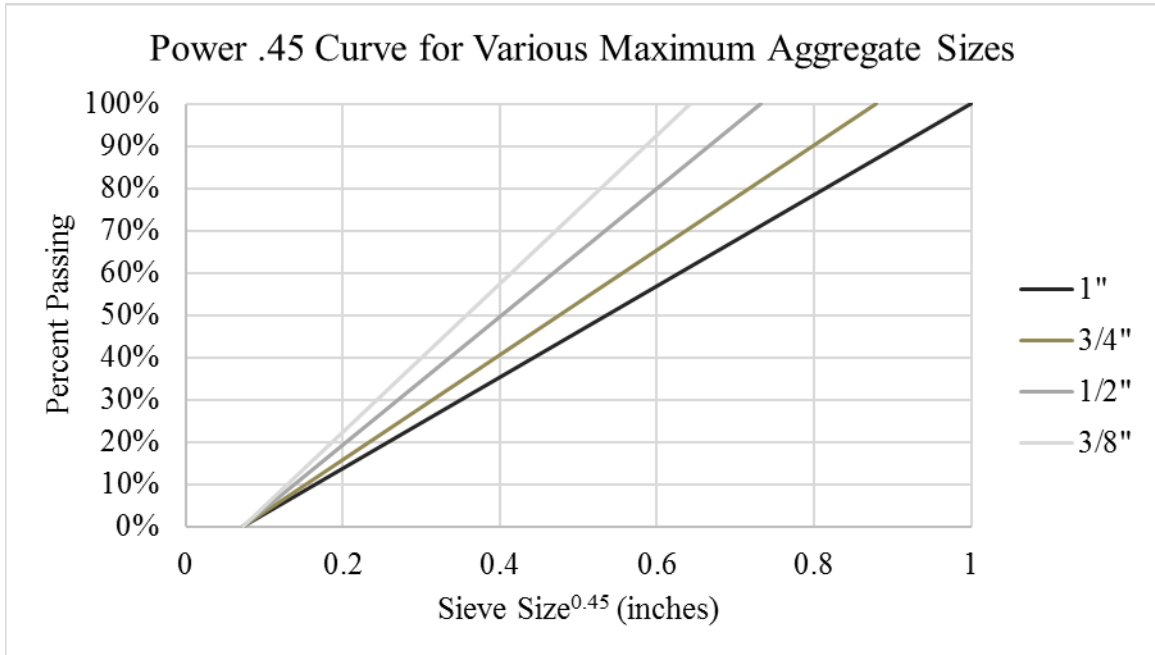

Figure 2-5: Power .45 Curves Used for Maximum Aggregate Density

### 2.1.3 Additional Cementitious Materials

#### 2.1.3.1 Fly Ash

Fly-ash is a byproduct of burning coal that has been crushed and ground. There are two groups of fly ash: Class F and Class C. These two groups are defined by the way they are produced. Class F fly ash is normally produced from coals with higher heat energy, such as bituminous and anthracite and Class C fly ash is typically produced from burning lignite or subbituminous coal, as defined in *ASTM C618: Standard Specification for Coal Fly Ash and Raw or Calcined Natural Pozzolan for Use in Concrete*. The largest difference between the two groups of fly ash in terms of chemical composition is that Class C fly ash has a significantly higher percentage of calcium oxide than Class F. Due to the different means of production, and therefore, different chemical composition, Class F and Class C fly ash have different performance characteristics.

As previously discussed, Class F and Class C fly ash are defined by the way they are produced. Therefore, the geographic availability of each group of fly ash is dependent on the type of coal that is burned in a specific area. It is not always economically achievable to have both groups of fly ash available to an area. This becomes important because a concrete mixture containing fly ash must comply with the availability of the product in a region.

In general concrete mixtures that contain fly ash as a partial replacement of Portland cement will have higher ultimate strengths but lower early strengths in comparison to concrete containing Portland cement as the sole cementitious material in the mixture (ACI Committee E-701 2013) (Akkaya et al. 2007). Class C fly ash typically shows a higher rate of reaction at early ages resulting in concrete with higher early strength than concrete containing Class F fly ash, but strengths are still lower than concrete containing only Portland cement. Elevated temperature curing has a greater effect on the strength gain of concrete containing fly ash than concrete without fly ash (ACI Committee 232 2003).

Fly ash also affects set time of concrete. Generally, fly ash has been found to retard the set time of concrete, with greater retardation occurring at higher replacement levels (Brooks et al. 2000). This property may be useful in hot weather concreting conditions.

Fly ash in concrete mixtures has been shown to improve the workability of concrete or to reduce the water to cementitious material ratio (w/cm) to maintain a given workability. This property has been attributed to the general spherical shape of fly ash particles (Brown 1980). The use of fly ash generally results in an increase in plasticity and cohesiveness, but the increase in cohesiveness assumes that the fly ash replaces the cement on a mass by mass basis and no adjustments are made to the proportions based on the change in specific gravity (volume of the paste) (ACI Committee 232 2003; Lane 1983).

The use of fly ash as a partial replacement of Portland cement, when compared to concrete mixtures containing only Portland cement, has proven to delay total shrinkage and cracking of the concrete through the reduction of autogenous shrinkage (Akkaya et al. 2007; Riding et al. 2008). Less autogenous shrinkage occurs when fly ash is used due to the reduction in heat of hydration, which lowers thermal strain.

Studies have shown that the permeability of concrete incorporating the use of fly ash is significantly lower than that of concrete without fly ash. This is due to the pore refinement that occurs as a result of the long term pozzolanic action of fly ash (ACI Committee E-701 2013). Decreased permeability will have positive effects on the long-term durability of the concrete. Since the primary use of the concrete mixtures developed in this research are for areas where deicing salt use is anticipated, high permeability detrimentally affects durability. Consequently, fly ash will be tested as a partial replacement of Portland cement during this research project to control shrinkage strains and to provide long-term durability. To increase the early strength of concrete as desired for this project, the use of chemical admixtures was investigated.

Typical values for fly ash replacement of Portland cement is 15 to 35% by mass of total cementitious material (ACI Committee 232 2003). Class F fly ash is recommended to be added at smaller replacement percentages than Class C, where Class F fly ash replacement ranges between 15 to 25% of cement by mass and Class C fly ash typically is used to replace 20 to 35% of cement content by mass (ACI Committee 211 2008). The most effective method to determine the performance of a given quantity of fly ash in a concrete mixture and establish the desired mixture proportions is to conduct trial batches using the aggregates and cement that will be used for the mixture.



## 2.1.4 Chemical Admixtures

### 2.1.4.1 Water-reducing Admixtures

There are many different types of water reducing admixtures, including conventional water reducers, mid-range water reducers and high-range water reducers (HRWR). The purpose of water reducing admixtures as stated by ACI Committee 212.3R (2010) in their *Report on Chemical Admixtures for Concrete* is to: “reduce the water requirement of the mixture for a given slump, produce concrete of higher strength, obtain specified strength at lower cement content, or increase the slump of a given mixture without an increase in water content.” Conventional water reducers will reduce the water added to concrete between approximately 5 and 12% and HRWRs will reduce the water by more than 30%, with mid-range water reducers falling somewhere in between (ACI Committee E-701 2003).

There are many potential benefits of using HRWR, also known as superplasticizers, rather than conventional or mid-range water reducers as defined by ACI Committee E-701. HRWRs act in a similar manner to conventional water reducers, except that HRWRs have a greater dispersion effect on cementitious materials. One of the primary differences between high range water reducers and conventional water reducers is that high range water reducers may minimize set retardation that may occur when using conventional water reducers. The use of HRWR has also shown to improve strength properties of hardened concrete. The strength of concrete containing HRWR is normally higher than what is expected of the lower w/cm ratio alone.

There are also several potential disadvantages of using HRWR instead of conventional or mid-range water reducers. One disadvantage is the greater cost of the HRWR admixture. The other drawback of using HRWR in concrete is that their effect on increasing slump is only maintained for about 30 to 60 minutes, making it difficult to place concrete (ACI Committee E-

701 2003). Due to the short window of workability time, HRWR can be, and often is, added at the jobsite.

A study performed by Han et al. (2013) performed to determine the effect of HRWR on strength of concrete investigated the effect of various HRWR dosages to cement ratios (by mass), in the range from 0 to 1.2%. These dosages were studied for a high and low w/cm ratio. The optimum HRWR dosage leading to the ideal dispersion of cement particles in the mortar and maximum compressive strength was found to be 1% for the w/cm ratios studied (0.3 and 0.6).

Water reducing admixtures have also shown to increase the entrained air in concrete (ACI Committee E-701 2003; Kosmatka et al. 2003). Consequently, the air content in the mixture should be checked when water reducers are used, and the air entraining admixture dosage may have to be modified. Water reducing admixtures may also increase drying shrinkage, despite the water reduction. This increase is typically small compared to other factors that cause shrinkage (Kosmatka et al. 2003).

#### ***2.1.4.2 Shrinkage Reducing Admixtures***

Shrinkage-reducing admixtures are organic based formulations that reduce surface tension of water in capillary pores of concrete. By reducing the surface tension of this water, the tensile forces within the overall concrete matrix are reduced causing a reduction in drying shrinkage (ACI Committee E-701 2003). Shrinkage-reducing admixtures have been proven to significantly reduce overall drying shrinkage potential, including the shrinkage rate and restrained shrinkage cracking (Folliard and Berke 1997; See et al. 2003). Shrinkage-reducing admixtures have proven effective even with very short moist curing periods.

Shrinkage reducing admixtures should be used with caution when high-early strengths are desired because concrete containing shrinkage-reducing admixtures have exhibited lower early strengths than concrete without shrinkage-reducing admixtures (Folliard and Berke 1997).

Shrinkage-reducing admixture alone did affect the set time of concrete, but in combination with superplasticizer it caused a retarding effect on the initial and the final set times up to 10 percent (Brooks et al. 2000). For these reasons, the use of shrinkage reducing admixtures were not considered a priority to satisfy the main objective of this research project.

#### ***2.1.4.3 Accelerating Admixtures***

Accelerating admixtures are used to accelerate the rate of hydration that occurs in concrete, which accelerates the set time and the early strength development of concrete. There are many chemicals used to accelerate the rate of hydration, but calcium chloride is the one most commonly used in accelerating admixtures. Calcium chloride has been proven to shorten the set time and accelerate the early strength development. The increased rate of hydration will also result in other benefits including earlier finishing time, reduced bleeding, improved protection against early exposure to freeze thaw cycles and earlier use of a structure.

There are also some disadvantages with using calcium chloride as an accelerating admixture, including an increase in drying shrinkage, potential for causing corrosion of reinforcing steel, and discoloration of concrete. Calcium chloride accelerating admixtures should be used with caution. They should always be added to the concrete in a solution form, which can be achieved by mixing with water. Calcium chloride use should be avoided in reinforced concrete that is in a moist condition. Even with non-reinforced concrete, the amount of calcium chloride used should never exceed 2% by mass of cementitious material (ACI Committee E-701 2003; Kosmatka et al. 2003). Other types of accelerating admixtures that do not contain chlorides are typically not as effective as those that do.

## 2.1.5 Proportioning

### 2.1.5.1 Water-to-Cementitious Materials Ratio

The water-to-cementitious materials ratio (w/cm) has a significant impact on many properties of plastic and hardened concrete. In fact, w/cm has been recognized as the most important quantity associated with strength and durability (Hover and Stokes 1995). Many studies have shown the correlation between compressive strength and permeability with w/cm, such as the one shown in Figure 2-6. Lower w/cm ratio results in higher compressive strength and lower permeability. By lowering the w/cm ratio, the water content is decreased and in turn, drying shrinkage and cracking is also reduced (Kosmatka et al. 2003).

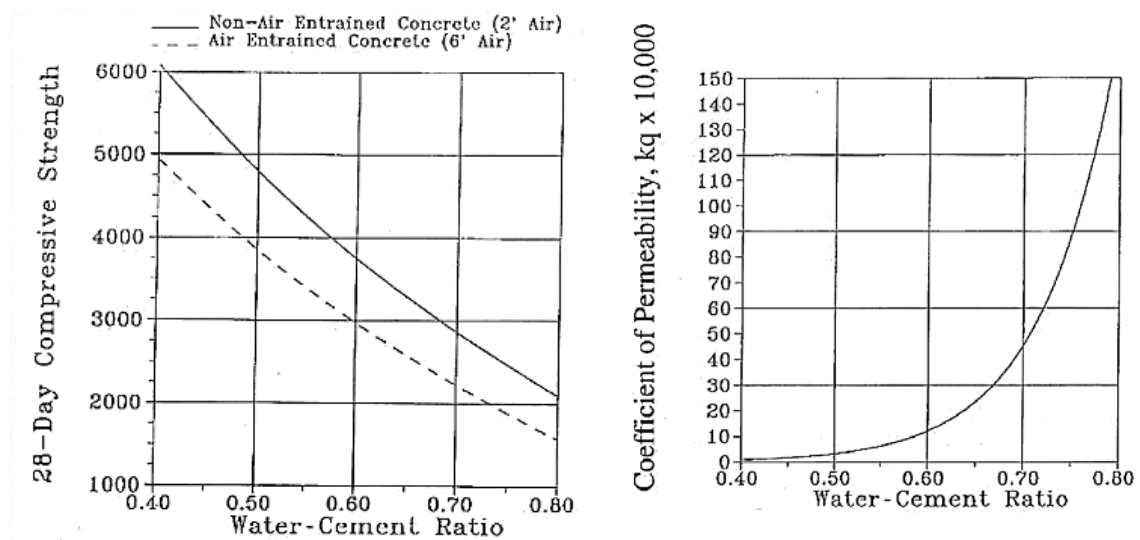

Figure 2-6: Strength and Permeability as a Function of W/CM (Hover and Stokes 1995)

Although low w/cm ratios have long-term as well as short-term benefits, low w/cm ratios have a negative effect on the workability of concrete. Lower slump results from having a low w/cm ratio in the mixture. To utilize the high strength and low permeability properties of low w/cm ratios without compromising workability, other cementitious materials or chemical admixtures such as water reducers can be used. The use of chemical admixtures and other

cementitious materials has proven essential to improve placement of concrete with low w/cm ratios. Guidelines for choosing a w/cm ratio for high-strength concrete can be found in ACI 211.4R (ACI Committee 211 2008).

### ***2.1.5.2 Volume of Paste***

The amount of cement paste in a concrete mixture must be determined to fill the voids between aggregates, as well as cover the aggregates and separate them to reduce inter-particle friction between aggregates while the concrete is in its fresh state (Koehler 2014; Kosmatka et al. 2003; Taylor et al. 2015). Figure 2-7 shows hardened concrete cylinders containing various volumes of cement paste. The figure illustrates air voids that can form in concrete when the volume of cement paste in the concrete mixture is insufficient. The parameter that defines the required amount of paste within the aggregate system is the paste-to-voids volume ratio ( $V_{\text{paste}}/V_{\text{voids}}$ ).  $V_{\text{paste}}$  is simply the volume of paste in a concrete mixture, where the paste includes the cementitious materials and water in concrete.  $V_{\text{voids}}$  is the volume of voids between compacted, combined coarse and fine aggregates. There is no optimal  $V_{\text{paste}}/V_{\text{voids}}$  ratio, but the ideal ratio for most concrete mixtures typically lies within the range of 1.25 to 1.75. Increased  $V_{\text{paste}}/V_{\text{voids}}$  has shown to increase chloride penetration and also affect slump and compressive strength of concrete mixtures (Taylor et al. 2015).



Figure 2-7: Cylinders of Concrete Made with Increasing Paste Volume from Left to Right (Taylor et al. 2015)

### **2.1.6 Curing Conditions**

The curing temperature of concrete is arguably the one parameter that has the most significant effect on the rate of hydration (Schindler 2004), and, therefore, has a highly significant effect on strength gain of concrete. Early strength of concrete is increased with higher curing temperatures due to the more rapid hydration. Alternatively, the ultimate strength of concrete typically decreases with higher curing temperatures (Mindess and Young 1981). Since high-early strength development is the priority in this research project, higher curing temperatures are beneficial. For hot-weather curing, this will not be an issue. For cold-weather curing, there are measures that can be taken in the field to ensure the necessary curing temperature will be maintained, such as heating blankets. Heating blankets can be used to heat concrete up to 60°F above ambient temperature at curing, as stated by Heat Authority, a heating blanket company (Heat Authority 2015).

Although hot-weather curing is not a cause for concern in terms of curing temperature, it can be a concern for plastic shrinkage. Concrete that is cured in hot-weather conditions should be protected from drying elements, such as direct sun or wind, and should be covered after finishing, even before moist curing begins (Mindess and Young 1981).

## **2.2 State of Practice**

As part of the literature review for this project, a survey on application and practices using high-early strength concrete was prepared and distributed to DOTs, other transportation agencies and pre-casters throughout New England. This survey information was collected to supplement the information found from research reports and technical papers. From this survey, key performance features required of ABC closure pour concrete mixtures were documented as well as past concrete mixes that were used for this application.

### **2.2.1 State of Practice Mix Designs**

Ten concrete mixture designs used for accelerated bridge construction closure pour connections were collected from DOTs and pre-casters throughout New England. Many of these concrete mixtures were found to be proprietary due to the use of specialty or blended cements. The concrete mixtures using proprietary, blended cements reached strengths as high as 3450 psi (24 MPa) in 2 hours, which is significantly higher than the target strength of this project, as described in Section 1.2 (4000 psi compressive strength in 12-hour). The remaining concrete mixtures obtained from the survey responses utilize the high-early strength properties of ASTM Type III Cement. These mixtures reached about 2500 psi (17 MPa) in 24 hours; these strengths are significantly lower than the desired strength gain for this application. The maximum coarse aggregate size in these mixes varied from 3/8" to 1" and the water to cementitious materials (w/cm) ratio varied from 0.26 to 0.41. The types and dosage of chemical admixtures added to each concrete mixture also varied; the following chemical admixtures were used in one or more of the state-of-practice mixtures: air entrainer, water reducer, corrosion inhibitor, shrinkage reducer, retarder, stabilizer and accelerator. The state-of-practice concrete mixtures currently used for accelerated bridge construction closure pours vary greatly. The ten collected concrete mixture designs can be found in Table 2-1. The non-proprietary concrete mixtures from the survey were used as a baseline for concrete mixture design development in this project. Details regarding the use of these concrete mixtures can be found in Section 3.3.1.

Table 2-1: Compilation of State-of-Practice Concrete Mixtures used for Accelerated Bridge Construction Closure Pours in New England

Component	Material	Quantity / yd <sup>3</sup> of Mixture										Units
		SOP-1	SOP-2	SOP-3	SOP-4	SOP-5	SOP-6	SOP-7	SOP-8	SOP-9	SOP-10	
Coarse aggregate	1"				1373					1541	1539	lb
	3/4"	1150	1460						1800			lb
	1/2"					1566						lb
	3/8"	500					1450	1500				lb
Fine aggregate	Concrete sand	1170	1340	1524	1409	1265	1600	1500	1200	1323	1210	lb
Cement	Type III Portland Cement	680	600									lb
	Type I/II Portland Cement			775								lb
	Specialty/Blended				801	801	559	750	666	725	680	lb
Fly ash	Class F	170	150				99				120	lb
Silica Fume	N/A			50								lb
Free Water	N/A	26.3	28.5	31.0	30.8	31.9	35.5	30.0	32.5	29.0	26.5	gal
Chemical Admixtures	Air Entrainment	12	38	2.6		29				12	7.3	oz
	Water Reducer	51	195	50						80	64	oz
	Stabilizer			17						80	64	oz
	Corrosion Inhibitor	640										oz
	Accelerator			165								oz
	Retarder									10	17	oz
	Shrinkage Reducer		192									oz
Reported Compressive Strength (psi)		3500 36-hour	2500 24-hour	5100 28-day	3450 2-hour	2900 2-hour	4000 3-hour	3700 3-hour	2000 6-hour	5600 3-hour	6000 3-hour	



### 2.2.2 Key Performance Features of ABC Closure Concrete (from survey)

Responses regarding key performance features were collected from the survey sent to DOTs and pre-casters and compiled in Figure 3-1. Where single values are reported, all survey responses reported the same value.

Table 2-2. Many of the responses had a great range of values. Some of the performance features did not receive many responses, such as flexural strength, bond strength and shrinkage. The minimum workability time and compressive strength seemed to be areas of vast importance. The responses for minimum workability ranged from 30 to 90 minutes. The responses for the compressive strength values showed that the target strength of 4000 psi in 12 hours set for this project is acceptable. Some responses indicated that reaching 2500 psi in 12 hours would even be sufficient. These responses were considered for the mixture design specification as well as the first round of trial batches, as described in Figure 3-1. Where single values are reported, all survey responses reported the same value.

Table 2-2: Key Performance Features of ABC Closure Pour Concrete Collected Compiled from Surveys

<b>Performance Feature</b>	<b>Responses</b>
Workability Time (minutes)	30 - 90
Air Content (%)	3 - 7
28-Day Bond Strength (psi)	2200
28-Day Flexural Strength (psi)	1200
Chloride Permeability (coulombs)	1500
Shrinkage Values at 28 Days (%)	0.04
Freeze-thaw Relative Dynamic Modulus (%)	80 (300 cycles); 91 (1000) cycles
Freeze-thaw Durability Factor	80
12-Hour Compressive Strength (psi)	2500 - 4000

### 3 DEVELOPMENT OF CONCRETE MIXTURE DESIGN

#### 3.1 Methodology

To develop the concrete mixture designs intended for the application specified in Section 1.2: Research Objective, a series of iterative trial batch concrete mixtures were conducted. The trial batch concrete mixtures had a goal of achieving adequate strength and constructability, while taking measures to generate a concrete mixture with durable properties. The iterative process of mixing and testing trial batch concrete mixtures led to the development of two selected concrete mixture designs. Two of the concrete mixtures, which satisfied the target strength and constructability properties were selected for further testing. Once selected, a set of additional short-term tests were conducted. For this research project, short term tests refer to tests that take less than 30 days to complete. One of the selected mixtures was used in a closure pour application to simulate the condition in the field corresponding to joining two precast bridge deck panels. In addition to examining the constructability in a more realistic condition, the specimens were tested to failure to investigate their load transfer capabilities. Finally, a concrete mixture design specification was developed for ABC closure pour concrete mixtures, where guidelines are provided to develop concrete mixtures for this specific application. A flowchart depicting the experimental testing plan is shown in Figure 3-1. This section provides an overview of the experimental testing performed throughout this project, which is shown in this figure. This section also discusses the trial batches which were mixed and tested, as well as the iterative process used to develop the concrete mixtures designs. In other words, this section covers up to the “selected concrete mixtures” step in Figure 3-1. A full report of trial batch test results is provided in Section 5. Test results of the selected concrete mixtures, depicted by the final box in the schematic shown in Figure 3-1, are discussed in Section 5 as well.

### 3.1.1 Trial Batches

An essential process used for concrete mixture design is the development of trial batches, which is used to determine preliminary compliance. For this research project, three selected performance requirements were used to evaluate whether a concrete mixture design met strength and constructability needs. The tests performed at this stage along with the corresponding standards used to perform each of these tests can be found in Table 3-1. This iterative process is depicted in Figure 3-1 as a loop that starts with trial batches and ends with selected concrete mixtures.

The compressive strength was used to determine if the concrete reached the target compressive strength of 4000 psi in 12 hours. Strength gain curves, shown in Section 5.1.1, were also constructed from the compressive strength tests and used to evaluate strength gain.

Either a slump or spread test was performed on each trial batch concrete mixture; the decision of which test to run was determined as described in Section 4.5.2.1. The slump or spread test was used to determine if the concrete had adequate workability and flowability for an ABC closure pour application. A concrete mixture with a workability that yield a slump greater than 3 inches without segregation is considered acceptable. Acceptance criteria will be further developed throughout the project. The set time test determined both the initial and final sets of concrete mixture trial batches. Measuring set times ensures that adequate time before hardening is achieved. Results of the slump, spread and set time testing can be found in Section 0.

Trial batch concrete mixtures were altered until the desired strength and constructability properties were reached. As mentioned, once the desired strength and constructability properties were reached, two of the concrete mixture designs that reached the preliminary goals were chosen to move forward with further testing.

### 3.1.2 Additional Short-term Testing

The additional short-term tests performed on the two selected concrete mixtures are shown in

Table 3-2. The air content was determined and used as an indicator of freeze-thaw resistance, which is an important property to enhance long-term durability.

The bond strength between the concrete and reinforcing bars was evaluated using a bar pullout test. Two typical sizes of reinforcing bars used in concrete decks, No. 4 and No. 6, were used for the bar pullout test. The reinforcing bars were epoxy coated in this test method, also to mimic typical connections in ABC.

Table 3-1: Short-term Tests Performed at Trial Batch Stage

<b>Concrete Property</b>	<b>Standard Followed</b>
Compressive Strength	ASTM C39-14
Slump or Spread	ASTM C143-12 or ASTM C1611-05
Set Time	ASTM C403-08

Table 3-2: Short-term Tests Performed on Developed Concrete Mixture

<b>Concrete Property</b>	<b>Standard Followed</b>
Air Content	ASTM C231-10
Concrete to Rebar Bond Strength (Bar Pullout)	ASTM A944-10
Confined Shrinkage (Ring Test)	AASHTO PP 34-99 (2005)
Alkali Silica Reactivity	ASTM C1567-07

The shrinkage of the selected concrete mixtures was measured using a confined shrinkage ring test. This shrinkage test was intended to be a comparative test that measures time until cracking and shrinkage rate. Since this test was comparative, it was also performed on “normal” concrete (as defined in Section 5.3.1) and compared to the two selected concrete mixtures.

The final short-term test that was performed on the two selected concrete mixtures was an alkali-silica reactivity (ASR) test. This test was used to determine the reactivity potential of aggregates used in the two selected concrete mixtures with Type III ASTM Cement and Class F fly ash. If an alkali-silica reaction takes place a concrete mixture, it produces expansion of hardened concrete causing disintegration of concrete elements in relatively short periods of time. ASR may be triggered when aggregates containing silica react with cement or cementitious materials used in a concrete mixture. The accelerated test procedure used for this research project detects the potential for ASR in as little as 14 days, compared with over 2 years needed for other tests used to determine ASR (ASTM C1293). Results from this test, however, should be used with caution since the test may sometimes falsely identify concrete with good field performance as having the potential for ASR. The results from each of these four short-term tests are reported in Section 5.3.4. Other ASR accelerated testing procedures were not considered in this project.

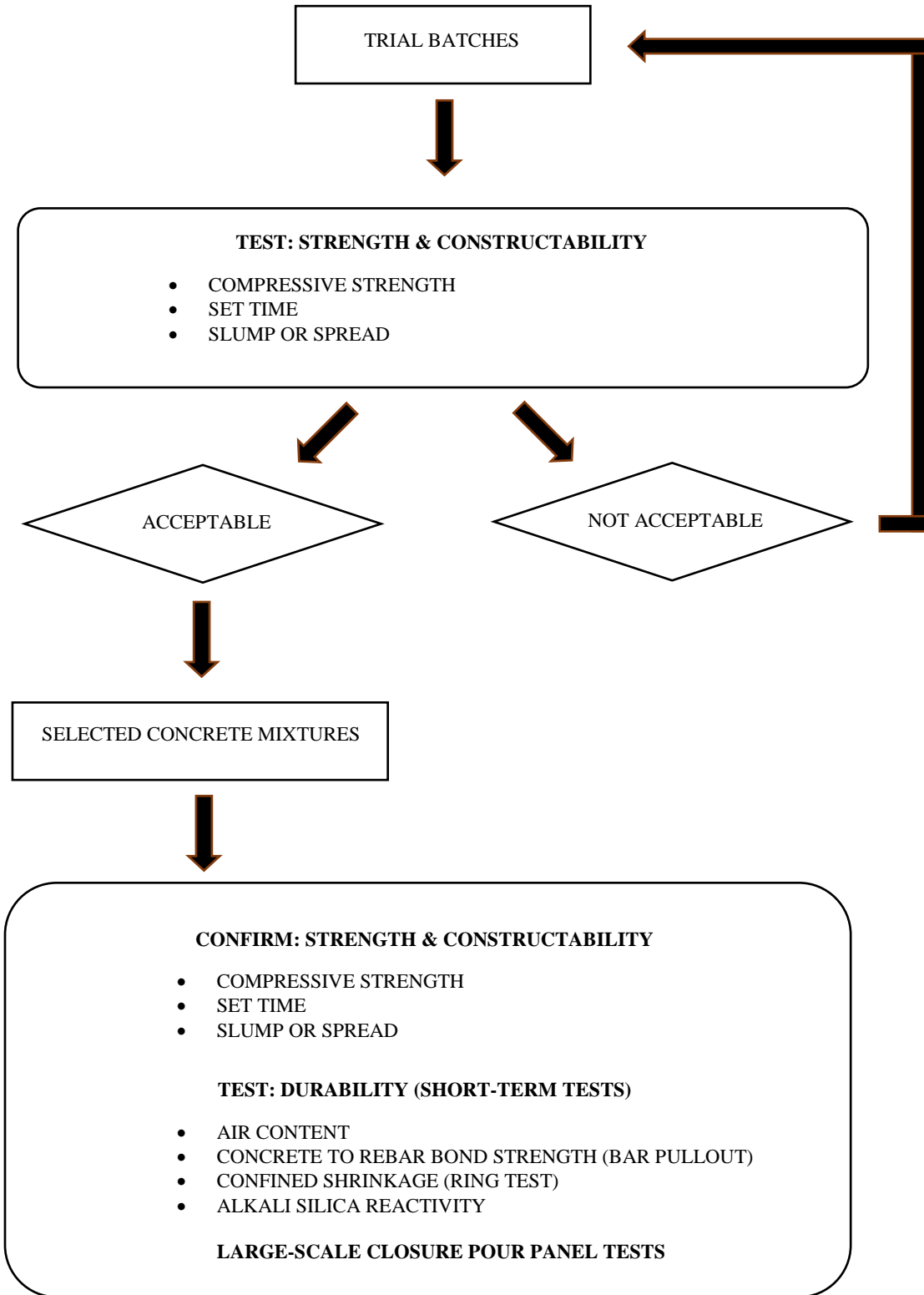

Figure 3-1: Flowchart of Experimental Testing Procedure

### 3.1.3 Long-term Testing

The two long-term tests that are recommended to be performed on the two concrete mixtures can be found in Table 3-3. Because of the timeline of the project, only freeze-thaw resistance testing was performed at a MassDOT testing facility. Chloride permeability testing is recommended to gain a more complete understanding of durability properties of the two selected concrete mixtures.

Table 3-3: Long-term Tests Prepared to Run on Developed Concrete Mixture

Concrete Property	Standard Followed
Freeze-Thaw Resistance	ASTM C666-08
Chloride Permeability	ASTM C1543-10a & ASTM C672-12

## 3.2 Materials

The first step in designing trial batch concrete mixtures is to determine the materials to be used. This section will describe which aggregates, cementitious materials and chemical admixtures were used for the trial batch concrete mixtures in this research project.

### 3.2.1 Aggregates

Two aggregate sources were used for this project, for both the fine and coarse aggregate. Aggregates from these two sources were not considered reactive. The aggregate sources were chosen based on proximity to the laboratory; they are both located in Western Massachusetts, and, therefore easily accessible for this research project, which was performed in University of Massachusetts laboratories. One source, Source 1, was Delta Sand and Gravel, Inc., located in Sunderland, MA. The other source, Source 2, was J.S. Lane & Son, Inc.; the coarse aggregate quarry was located in Amherst, MA and the fine aggregate pit was located in Westfield, MA.

Source 1 provided coarse and fine aggregate developed from river stone. Source 2 also provided a river stone fine aggregate, but the coarse aggregate was a crushed basalt stone. The river stone coarse aggregate (Source 1) has properties that are round and smooth. The crushed stone coarse aggregate (Source 2) has properties that are more angular and rough. The aggregates from Source 1 and Source 2 and shown in Figure 3-2 and Figure 3-3, respectively. More information on the aggregates properties, including gradation, absorption and various densities can be found in Appendix A.



Figure 3-2: Source 1 Aggregates. From Left to Right: 3/4" Coarse Aggregate, 1/2" Coarse Aggregate, Fine Aggregate



Figure 3-3: Source 2 Aggregates. From Left to Right: 3/4" Coarse Aggregate, 1/2" Coarse Aggregate, 3/8" Coarse Aggregate, Fine Aggregate



Based on the literature review, it was assumed that crushed stone (Source 2 coarse aggregate) would provide greater strength but less workability, and alternatively, the river stone (Source 1 coarse aggregate) would provide greater workability but lower strength due to texture and shape properties of the two aggregate sources. To determine which aggregate source to use, the desired workability and strength properties of the concrete were considered. Based on survey responses from regional DOTs and pre-casters (Section 2.2), the workability of state-of-practice concrete mixtures used for closure pour applications was typically not within desired limits, making it difficult to place in the field. Therefore, workability was considered a property of concern during mixture development. High early strength was of highest priority in the development of this concrete mixture. Source 1 coarse aggregates were used initially, but when the target strength (4000 psi in 12 hours) was not being reached, the coarse aggregate source was switched to Source 2. The workability seemed more feasible to correct using other measures, such as chemical admixtures, than problems observed with slow strength gain.

The fine aggregates from Source 1 and Source 2 had similar aggregate properties, such as stone type, gradation and densities. The fine aggregate source used was always the same as the coarse aggregate source. In other words, if the Source 1 coarse aggregate was used in a concrete mixture, the Source 1 fine aggregate was used in that concrete mixture. Similarly, if the Source 2 coarse aggregate was used in a concrete mixture, the Source 2 fine aggregate was used in that concrete mixture. Subsequently, the Source 2 coarse and fine aggregates were used in the majority of the concrete mixtures in this research project.

### **3.2.2 Cementitious Materials**

As discussed in Section 2.1, ASTM Type III cement has proven to achieve the highest rate of compressive strength development allowing the mixtures to reach the target strength at early ages. Therefore, ASTM Type III cement was the only cement type considered throughout this

project. During preparation of the proposal for this research project, Northeast PCA was contacted to ensure availability of Type III cement in the region. Although not widely available, it was indicated that Type III cement could be acquired in bulk within the region.

Class C and Class F fly ash as defined by *ASTM C618* were both considered for use in this research. It appeared, based on the literature review, that Class C fly ash would produce concrete with a higher early strength gain than Class F fly ash. However, Class C fly ash is not available for use in New England. The distance that the Class C fly ash would have to be shipped for use in New England is not an economically feasible solution for regular use. Since the concrete mixtures developed from this research project have intended use in the New England region, Class C fly ash was not an ideal choice, and the results found from using Class C fly ash would have had to be significantly different from those found from using Class F fly ash to validate its use. Both types of fly ash used in this project were sourced from Headwaters Resources. Class F fly ash was produced in Brayton Point Plant, located in eastern Massachusetts and Class C fly ash was produced in Miller Plant located in Alabama.

No other cementitious materials (slag, silica fume, metakaolin) were considered for this study. These materials have conflicting reviews regarding their high-early strength properties, especially in combination with other cementitious materials. Therefore, the research only investigated the use of fly ash in the mixes.

### **3.2.3 Chemical Admixtures**

The chemical admixtures used for this project were an accelerator and a high-range water reducer. Admixtures were supplied by W.R. Grace and Company for the majority of the concrete mixtures. Euclid Chemical admixtures were used when reproducing a concrete mixture design reported during the state-of-practice survey, where the concrete mixture used Euclid Chemical admixtures. Select concrete mixtures developed with W.R. Grace and Company admixtures were

mixed using Euclid Chemical Admixtures to analyze the effect of the chemical admixture supplier on the concrete mixture properties.

### **3.3 Proportioning**

Various methods were used to determine proportioning of the trial batch concrete mixtures. The first method used was to replicate select state-of-practice concrete mixtures, as described in Section 2.2.1. The compressive strength and constructability results from these trial batches were not satisfactory; therefore, two other methods were considered. One method was to follow the *Guide for Selecting Proportions for High-Strength Concrete Using Portland Cement and Other Cementitious Materials* written by ACI Committee 211 (ACI 211.4R) and the other was to use maximum compaction of aggregates, which has also shown to achieve high-strength of concrete, as discussed in Section 2.1.2.3 of the literature review. Both of these methods produced reasonably satisfactory results, in terms of compressive strength and workability. Test results supporting this statement can be found in Section 5. Although both methods produced acceptable results, the maximum compaction of aggregates method was chosen to be used for further trial batches. It was chosen over the ACI 211.4R Guidelines because of the clear proportions used with the maximum aggregate compaction and the greater understanding of how each proportion was developed. With clear proportions, a more comprehensive approach could be used when altering trial batches. Each of the three proportioning methods are described in the following subsections.

#### **3.3.1 Replication of State-of-Practice Concrete Mixtures**

The first trial batch concrete mixtures that were mixed and tested for this research project consisted of two state-of-practice concrete mixtures. The two state-of-practice concrete mixtures that were chosen from Table 2-1 were those that contained non-proprietary, ASTM Type III cement. The intention of mixing these concrete trial batches was to obtain compressive strength

results similar to those reported in Table 2-1, and then modify the concrete mixture designs to achieve other desired properties. When the state-of-practice concrete mixtures were mixed, the results obtained were not as expected; the compressive strengths were reaching less than half of the target compressive strength in the first 12 hours, and the consistency of the concrete was very stiff, almost to a degree where it could not be cast into cylindrical molds for the compressive strength tests. To improve these results, some slight modifications of the admixtures were made, such as increasing the high-range water reducer or decreasing the air-entraining admixture. These modifications made only slight changes to the compressive strength and workability properties of the concrete; therefore, at this point, it was decided to try different approaches to proportioning.

### **3.3.2 ACI 211.4 Guidelines Report Method**

As mentioned, one alternative approach used to determine optimal proportioning was the *Guide for Selecting Proportions for High-Strength Concrete Using Portland Cement and Other Cementitious Materials* written by ACI Committee 211 (ACI 211.4R). This guideline was followed step-by-step to determine concrete mixture proportions. *Step 1* in the guide requires a 28-day compressive strength target to be defined. Based on the target compressive strength of 4000 psi in 12 hours, the target 28-day compressive strength value was selected to be approximately 10,000 psi. This target 28-day compressive strength was used to provide guidelines on the maximum coarse aggregate size to be used.

The guide recommended for a target 28-day compressive strength equal to 9000 psi or greater, to use a maximum coarse aggregate size of either 3/8" or 1/2". As mentioned in Section 3, during the literature review, there are conflicting views on the effects the maximum coarse aggregate size has on strength development of concrete. The maximum aggregate size was chosen as 1/2" for a starting point, and a maximum aggregate size of 3/8" would have been considered as an alternative if necessary.

The target 28-day compressive strength was also used to determine the w/cm to use for the concrete mixture design. Based on the  $f'_c$  value of 10,000 psi, an  $f'_{cr}$  value was calculated to be 11,700 psi. Using the table shown in Figure 3-5 and an approximate  $f'_{cr}$  value of 12,000 psi, the w/cm ratio was selected to be 0.26.

In the ACI 211.4R guideline, the use of a HRWR admixture is provided as an option. The ACI 211.4 guideline states that the “HRWR dosage should be adequate for both the anticipated contribution to strength and desired workability.” For the ACI 211.4R concrete mixture trial batch, the HRWR dosage used was equal to 1% of the cementitious material by mass. This decision was based on a study performed by Han et al. (2013) on the effects of HRWR dosage. The HRWR used in the study was a polycarbonate-based HRWR, similar to the HRWR used the trial batch concrete mixtures of this research project. As shown in Figure 3-4, the study determines an optimal dosage of HRWR to be 1% of cementitious material by mass for w/c ratio similar to 0.29 (Han et al. 2013).

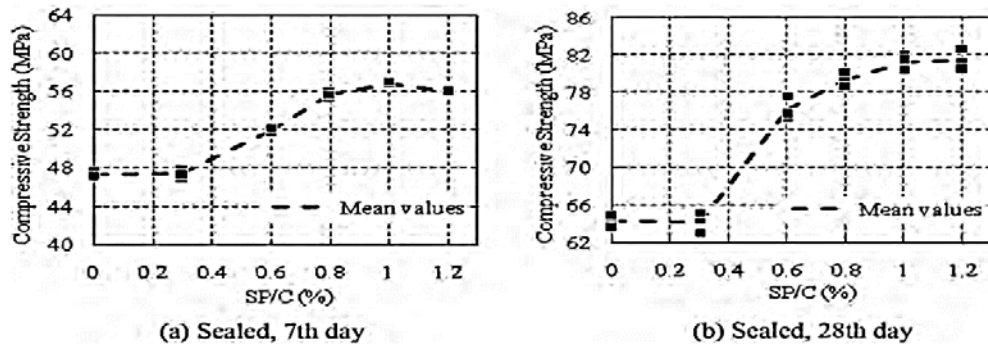

Figure 3-4: Compressive Strength vs. HRWR (Superplasticizer) Dosage as a Percentage of Cementitious Materials by Mass for W/C = 0.3 (Han et al. 2013)

The trial batch concrete mixture developed using the ACI 211.4R guidelines can be seen in Table 3-4. The compressive strength this trial batch concrete mixture reached in 12 hours was approximately equal to the target 12-hour compressive strength of 4000 psi. The set time tests indicated acceptable constructability, but the consistency of the trial batch concrete mixture was

very fluid and some segregation was observed. The compressive strength, slump and set time test results can be found in Section 5.

Table 3-4: Concrete Mixture Trial Batch Developed Using ACI 211.4R Guideline

Component	Material	ACI 211.4R Guidelines Mix	Units
Coarse aggregate	1/2" crushed stone	1753	lb
	3/8" crushed stone	-	lb
Fine aggregate	Concrete sand	490	lb
Cement	Type III portland cement	1079	lb
Fly ash	Class F	-	lb
Free Water	N/A	337	lb
Chemical Admixtures	Accelerator	-	fl oz
	Superplasticizer	4591	fl oz

### 3.3.1 Maximum Compaction of Aggregates

The other method used to determine optimal proportioning of the concrete was based on the maximum compaction of aggregates method. The maximum compaction of aggregates method determines the aggregate gradation used for a concrete mixture. The proportional quantities of water and cementitious materials needed to be determined using other methods in parallel with the maximum compaction of aggregates method. The following ratios were used to determine the other mixture quantities: w/cm, percent fly ash replacement and volume of paste to volume of voids (as discussed in the literature review, Section 2.1.5.2). These ratios, along with the aggregate gradation determined by maximum compaction of aggregates were used in combination to fully summarize the proportions of each trial batch concrete mixture using this method. The methods used to determine each of these ratios, including the aggregate gradations are described in the following sections.

SELECTING PROPORTIONS FOR HIGH-STRENGTH CONCRETE

211.4R-9

**Table 6.5—Recommended maximum  $w/cm$  for high-strength concrete**

Required average compressive strength $f'_{cr}$ ,* psi		$w/cm$							
		Maximum-size coarse aggregate, in.							
		3/8		1/2		3/4		1	
		with HRWRA	without HRWRA	with HRWRA	without HRWRA	with HRWRA	without HRWRA	with HRWRA	without HRWRA
7000	28-day	0.50	0.42	0.48	0.41	0.45	0.40	0.43	0.39
	56-day	0.55	0.46	0.52	0.45	0.48	0.44	0.46	0.43
8000	28-day	0.44	0.35	0.42	0.34	0.40	0.33	0.38	0.33
	56-day	0.48	0.38	0.45	0.37	0.42	0.36	0.40	0.35
9000	28-day	0.38	0.30	0.36	0.29	0.35	0.29	0.34	0.28
	56-day	0.42	0.33	0.39	0.32	0.37	0.31	0.36	0.30
10,000	28-day	0.33	0.26	0.32	0.26	0.31	0.25	0.30	0.25
	56-day	0.37	0.29	0.35	0.28	0.33	0.27	0.32	0.26
11,000	28-day	0.30	—	0.29	—	0.27	—	0.27	—
	56-day	0.33	—	0.31	—	0.29	—	0.29	—
12,000	28-day	0.27	—	0.26	—	0.25	—	0.25	—
	56-day	0.30	—	0.28	—	0.27	—	0.26	—

\* $f'_{cr}$  =  $1.10f'_c$  + 700 psi.

Figure 3-5: Recommended  $w/cm$  Ratios Provided by ACI 211.4R

### ***3.3.1.1 Aggregate Gradation***

As previously mentioned, using this method, the aggregate gradations were determined using maximum aggregate compaction, more specially, the Fuller Thompson curves, as described in Section 2.1.2.3 of the literature review. The coarse aggregate size is as defined from the aggregate source (quarry), where the majority of the aggregate is the size as labeled. The gradation curves for each aggregate size used in this research project can be found in Appendix A. As seen in Table 2-1, concrete mixtures typically contain one coarse aggregate size. This is due to efficiency in batching the concrete and simplicity in the concrete mixture proportions. Although, there can be value in mixing multiple coarse aggregate sizes, such as reducing any gaps in the gradation.

The maximum compaction analysis was initially performed using one coarse aggregate size in combination with fine aggregate, and then later the combination of two maximum coarse aggregates sizes, again in combination with fine aggregate was investigated. The first coarse aggregate size chosen was 1/2" aggregate; this decision was made based on the ACI 211.4R guidelines using the same reasoning described in Section 3.3.2. To determine the maximum aggregate compaction that can be achieved with 1/2" coarse aggregate in combination with fine aggregate, various 1/2" coarse aggregate to fine aggregate ratios, ranging from 0.5 to 2.5, were evaluated. Gradation curves were developed showing the aggregate size distribution which resulted from each of these ratios. The gradation curves were then plotted against the gradation curve defined by Fuller-Thompson maximum aggregate compaction for a maximum aggregate size of 1/2".

The maximum aggregate gradation possible with these two aggregate sizes was defined by how close the gradation curve was to the Fuller-Thompson gradation curve. To determine how close a maximum aggregate compaction gradation curve was to the Fuller-Thompson curve, the



strength of the linear relationship between the two curves was found using a linear correlation coefficient. The correlation coefficients for each 1/2" coarse aggregate to fine aggregate (CA/FA) ratio can be seen in Figure 3-7. As shown in this figure, the optimal 1/2" CA/FA ratio is 1.2 with a correlation coefficient of 0.984. The optimal gradation curve formed by a 1/2" CA/FA ratio equal to 1.2 is shown in Figure 3-6. Also in this plot, gradation curves formed by several other 1/2" CA/FA ratios are shown, demonstrating convergence to the optimal gradation curve for this size coarse aggregate.

As discussed in Section 3.3.3.6, studying trial batches with alternative coarse aggregate sizes was explored. The next coarse aggregate size used in the trial batch concrete mixtures was 3/8" coarse aggregate. Again, the maximum aggregate compaction that could be achieved with 3/8" coarse aggregate in combination with fine aggregate was found by evaluating various CA/FA ratios. The process used to determine the maximum compaction of 1/2" coarse aggregate in combination with fine aggregate was used. Gradation curves were formed using various 3/8" CA/FA ratios, again ranging from 0.5 to 2.5. Correlation coefficients were then calculated based on the linear relationship between each gradation curve and the 3/8" maximum aggregate compaction Fuller-Thompson gradation curve. The correlation coefficients found for the various 3/8" CA/FA ratios are plotted with the correlation coefficients found for the various 1/2" CA/FA ratios in Figure 3-7. The optimal 3/8" CA/FA ratio, as shown in Figure 3-7, is 1.0. It should be noted that there are different maximum aggregate compaction Fuller-Thompson gradation curves for different maximum coarse aggregate sizes. This is shown in Figure 3-8, where gradation curves formed by various 3/8" CA/FA ratios, including the optimal CA/FA ratio of 1.0, are plotted against the 3/8" maximum aggregate compaction Fuller-Thompson gradation curve.

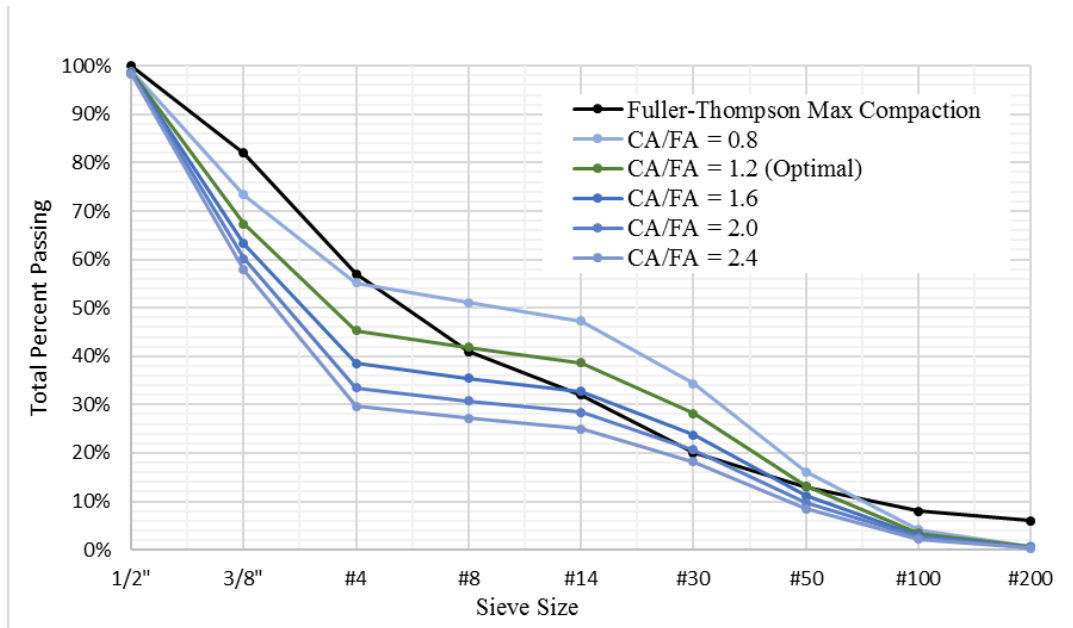

Figure 3-6: 1/2" Coarse Aggregate in Combination with Fine Aggregate Gradation Curves Plotted Against 1/2" Maximum Compaction Fuller Thompson Curves

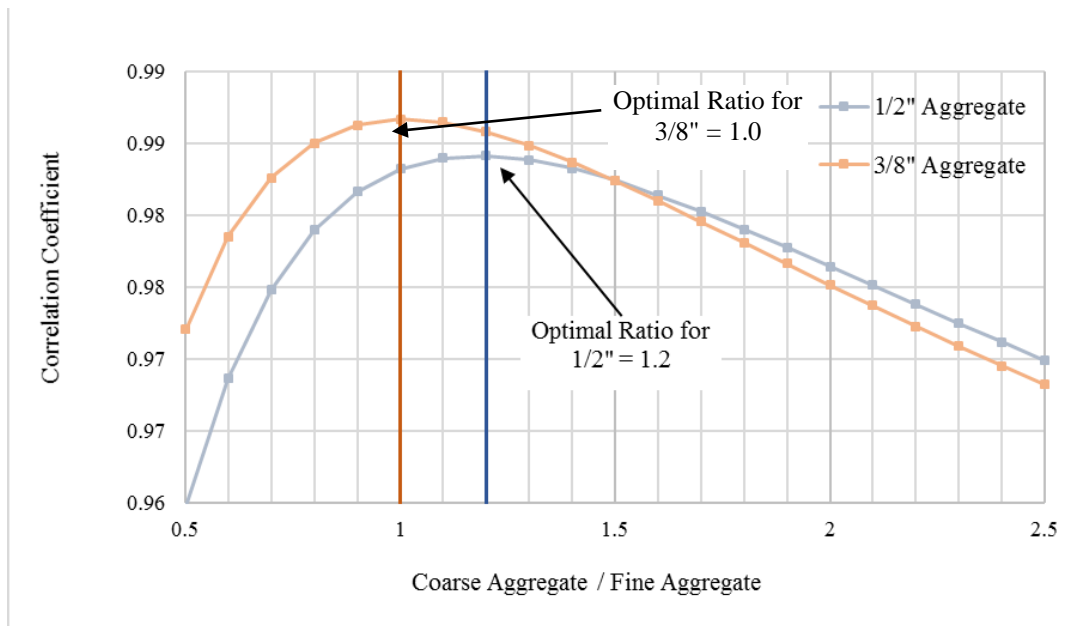

Figure 3-7: Correlation Between Fuller-Thompson Curves and One Coarse Size Aggregate (1/2" and 3/8")

The use of two coarse aggregate sizes was also considered during the trial batch concrete mixture development process. 1/2" coarse aggregate, 3/8" coarse aggregate and fine aggregate in

combination studied as a potential aggregate combination. Two ratios were used to define the aggregate proportions in this case: the CA/FA ratio, as used in the previous two cases, and the 1/2" coarse aggregate to 3/8" coarse aggregate ratio (1/2"/3/8" ratio). The range of CA/FA ratios evaluated was from 0.6 to 1.2 and the range of 1/2"/3/8" ratios evaluated was from 0.1 to 1.5 with every combination of the ratios considered. For each ratio combination, a gradation curve was formed and compared to the 1/2" maximum aggregate compaction Fuller-Thompson gradation curve. Even though there are two coarse aggregate sizes, the maximum aggregate size was 1/2"; therefore, the 1/2" Fuller-Thompson curve was used. Correlation coefficients were also calculated for this case and plotted against the two ratios, shown in Figure 3-9. This plot confirms that the optimal ratio combination of CA/FA equal to 0.7 and a 1/2"/3/8" ratio equal to 0.9 is encompassed by the ratio ranges chosen. Figure 3-10 shows the optimal gradation curve plotted along with the 1/2" maximum aggregate compaction Fuller-Thompson curve. On this plot, the gradation curve formed by the maximum aggregate compaction of only 1/2" coarse aggregate in combination with fine aggregate is also shown. It can be seen that with the addition of 3/8" coarse aggregate, the gradation curve has a slightly stronger linear correlation to the Fuller-Thompson curve. The correlation coefficient between the combined 1/2" and 3/8" coarse aggregate gradation curve and the Fuller-Thompson curve is 0.99, and it is only 0.98 for the case where 1/2" is the sole coarse aggregate size. Although the use of combined coarse aggregate sizes produced a slightly higher aggregate compaction, a larger gap in the aggregate gradation is formed.

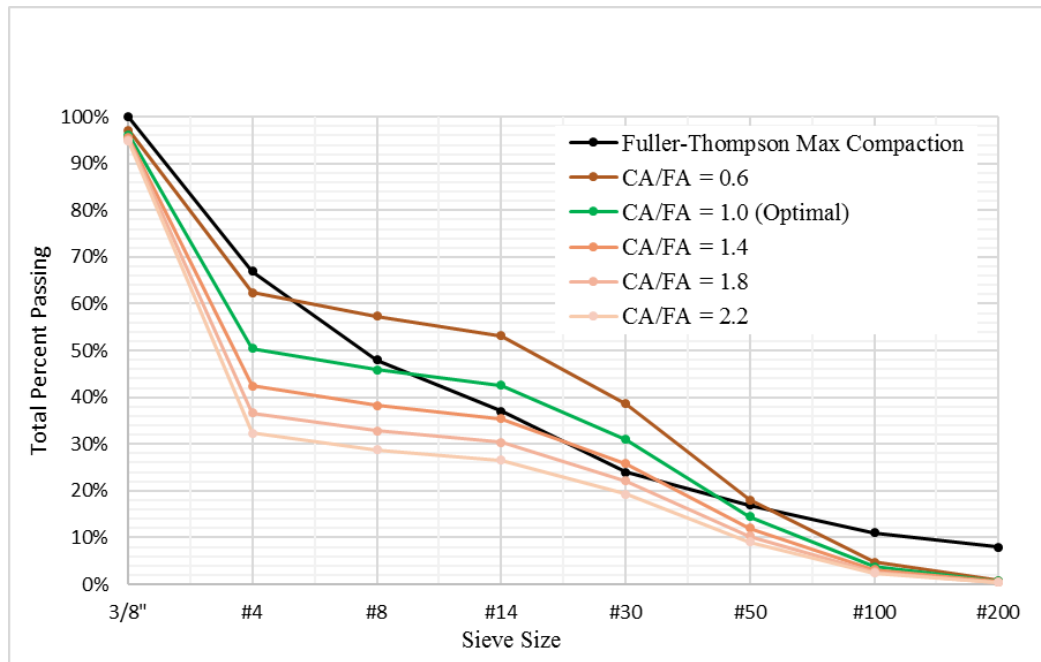

Figure 3-8: 3/8" Coarse Aggregate in Combination with Fine Aggregate Gradation Curves Plotted Against 3/8" Maximum Compaction Fuller Thompson Curves

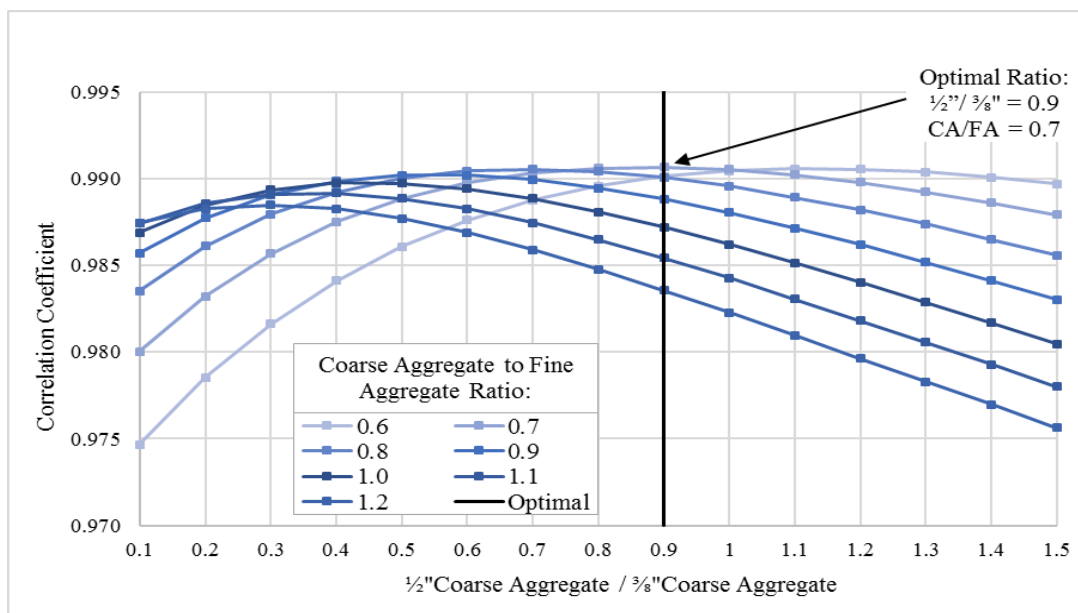

Figure 3-9: Correlation between Fuller-Thompson Curves and Two Coarse Size Aggregate (1/2" and 3/8")

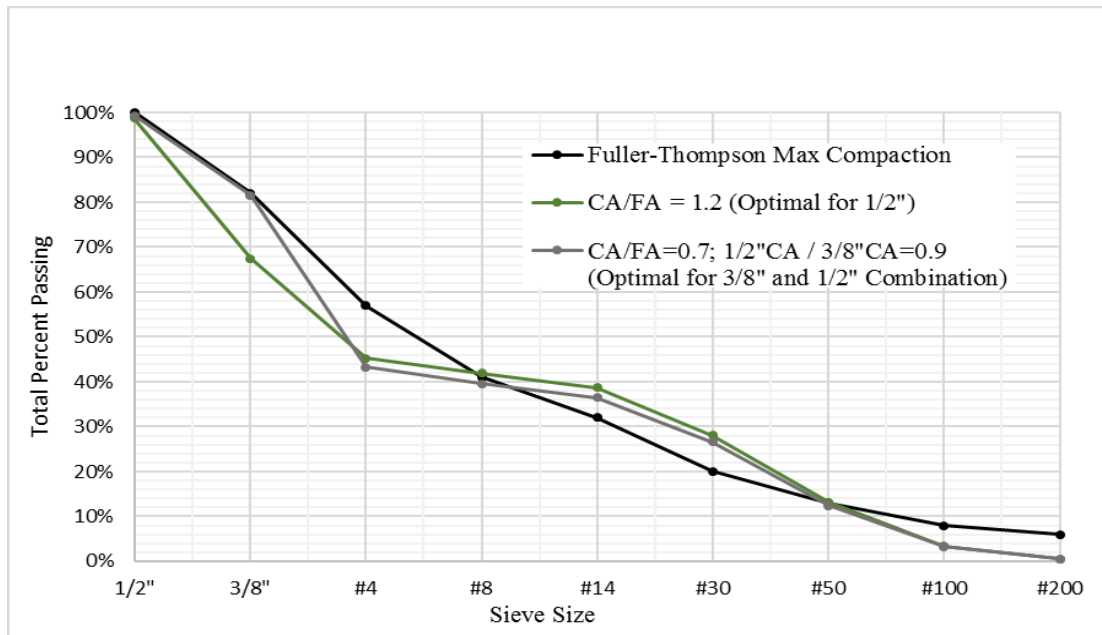

Figure 3-10: 1/2" Maximum Aggregate Size Gradation Curves Plotted Against 1/2" Maximum Compaction Fuller Thompson Curves

Gap gradation was evaluated for the three optimal gradation curves: maximum aggregate compaction with only 1/2" coarse aggregate, maximum aggregate compaction with only 3/8" coarse aggregates and maximum aggregate compaction with a combination of 1/2" and 3/8" coarse aggregate. Figure 3-11 demonstrates the gaps in aggregate gradation by calculating the difference in percent retained between two consecutive sieves sizes. As discussed in Section 2.1.2.3, to avoid gap gradation, the difference in percent retained on two consecutive sieves should be less than 35% (Koehler 2014); this is also depicted in Figure 3-11 as a solid line.

For the maximum aggregate gradation curved formed using 1/2" coarse aggregate only, the largest gap in aggregate size occurred between 1/2" and 3/8" aggregate, this can be seen in Figure 3-11 and in the gradation curve in Figure 3-10. This gap is equal to 31%, which is still less the upper recommended limit of 35%.

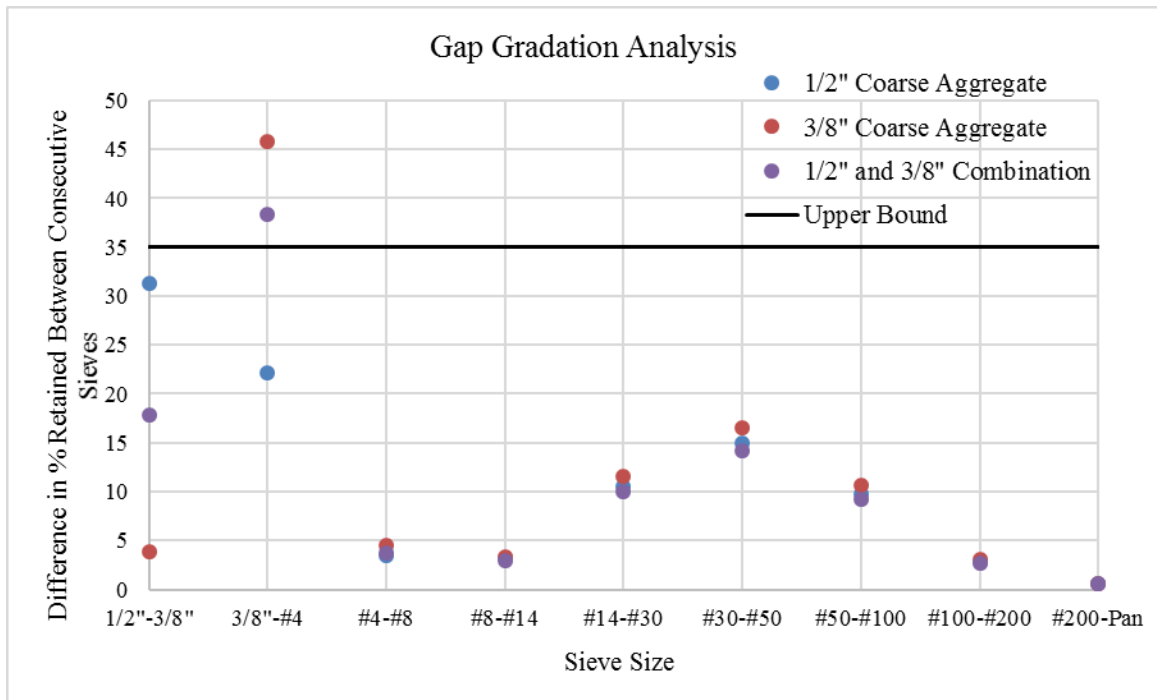

Figure 3-11: Gap Gradation Analysis of the Optimal Maximum Aggregate Compaction Gradation Curve for Each Coarse Aggregate Size Evaluated

When a combination of 1/2" and 3/8' coarse aggregate was used, the gap between aggregate sizes between 1/2" and 3/8" was only about 17% which was 14% less than the gap that occurred with only 1/2" coarse aggregate and much less than the recommended upper limit, as shown in Figure 3-11. Combining the 1/2" and 3/8' coarse aggregate sizes also brings the gradation curve closer to the Fuller-Thompson curve between 1/2" and 3/8" aggregates sizes, as shown in Figure 3-10. Alternatively, combining the two aggregate sizes brings the gradation curve farther away from the Fuller-Thompson curve between 3/8" and No. 4, when compared to 1/2" coarse aggregate only, also shown in Figure 3-10. This change is also demonstrated in Figure 3-11, where the largest gap, equal to 38%, occurs between aggregate sizes equal to 3/8" and No.4 for the combined coarse aggregate sizes. This is 7% larger than the percent difference

between 3/8" and No.4 aggregate sizes with 1/2" aggregate as the only coarse aggregate size, and it exceeds the recommended upper limit of 35%.

When 3/8" coarse aggregate is used as the only coarse aggregates size, there is also a gap in aggregate sizes which exceeds the 35% maximum percentage. The percentage difference between aggregates retained on the 3/8" sieve and the No. 4 sieve size 46% when 3/8" aggregate is the only coarse aggregate used, which is more than 10% higher than the recommended upper bound. This can also be determined by the change of percent retained values between the 3/8" and the No. 4 sieves for the optimal gradation curve in Figure 3-8.

Different mixtures containing the aggregate gradations determined for maximum compaction for the three options discussed in this section were developed to evaluate their strength gain and workability. The use of different coarse aggregate sizes affected the strength and consistency of the trial batch concrete mixtures, as shown in Table 3-5.

### ***3.3.1.2 Water-to-Cementitious Materials Ratio***

The baseline w/cm ratio used for trial batch concrete mixtures designed using the maximum aggregate compaction method was found from the ACI 211.4R guidelines. An initial w/cm ratio was chosen to be 0.26 using the procedure described in Section 3.3.2: ACI 211.4 Guidelines Report Method. A ratio of 0.29 and 0.32 were also used in the development of trial batch concrete mixture designs. A decrease in the w/cm ratio was used to increase strength of the trial batch concrete mixture. The w/cm ratio was also adjusted to improve the consistency, and, therefore the workability of the fresh concrete. A w/cm ratio equal to 0.29 was used in both of the selected concrete mixtures. The process followed to select this w/cm is described in Section 3.3.3.6.

### **3.3.1.3 Volume of Paste to Volume of Voids Ratio**

The volume of paste to volume of voids ( $V_{\text{paste}}/V_{\text{voids}}$ ) ratio is used as a way to determine the amount of paste that should exist within a concrete mixture. The  $V_{\text{paste}}/V_{\text{voids}}$  ratio is calculated by finding the paste volume of a concrete mixture and dividing it by the volume of voids between combined compacted aggregates. The paste is comprised of all cementitious materials and water (including any water contained in the admixtures used). As discussed in Section 2.1.5.2 of the literature review, the ideal  $V_{\text{paste}}/V_{\text{voids}}$  ratio typically lies within the range of 1.25 and 1.75. For this research project, a  $V_{\text{paste}}/V_{\text{voids}}$  ratio of 1.75 was chosen as a starting point for the trial batch concrete mixtures.

As will be discussed in Section 3.3.1.5, a high-range water reducer (HRWR) admixture was used in every trial batch concrete mixture. For the HRWR to work properly and provide adequate dispersion of water, there needs to be sufficient water available within the concrete mixture. As mentioned in Section 3.3.1.2, the trial batch concrete mixtures have low w/cm ratios, in the range of 0.26 to 0.32, and by having a low w/cm the total percentage of water in the concrete mixture is also lower. By using a high  $V_{\text{paste}}/V_{\text{voids}}$  ratio, the volume of paste increases within the concrete mixture, and therefore the total percentage of water also increases within the concrete mixture. For this reason, the initial  $V_{\text{paste}}/V_{\text{voids}}$  ratio chosen was 1.75, a ratio at the high end of the range provided.  $V_{\text{paste}}/V_{\text{voids}}$  ratios equal to 1.5 and 1.25 were also considered and used in select trial batch concrete mixtures, as shown in Table 3-5.

### **3.3.1.4 Fly Ash Replacement**

The use of fly ash was considered important for these mixtures since it a key component to reduce drying shrinkage potential that may occur in the trial batch concrete mixtures due the lower w/cm ratios. Fly ash was used a partial replacement of cement in the trial batch concrete



mixtures. As mentioned in Section 3.2.2, Class C fly ash can be expensive to obtain for use in New England. Therefore, Class F fly ash was the primary type of fly ash used in this research project, and Class C fly ash was used in only a few mixtures, primarily to evaluate if the results were significantly different than those obtained when using Class F fly ash. As discussed in Section 2.1.3.1 of the literature review, typical replacement percentages for Class F fly ash range from 15 to 25% and for Class C fly ash range from 20 to 35%. Fly ash replacement values within these ranges will be used for trial batch concrete mixtures.

### ***3.3.1.5 Chemical Admixtures***

#### **3.3.1.5.1 High-Range Water Reducing Admixture**

A high-range water reducer (HRWR) admixture was used in every trial batch concrete mixture to improve workability. Due to the high cement content and low w/cm ratios, HRWR was necessary to keep the concrete constructability within acceptable limits. The initial dosage of HRWR was determined based on the anticipated effects it would have on concrete compressive strength. As discussed in Section 2.1.4.1 of the literature review, a study was performed by Han et al. (2013) on the effects of HRWR on compressive strength of concrete. It was found that the optimal HRWR in terms of strength, is 1% of cementitious materials by mass, which is equivalent to 12.2 oz/cwt for the HRWR admixture used for this project. This is the HRWR dosage used for the majority of the trial batch concrete mixtures, including all of those shown in Table 3-5. It should be noted that the dosage recommended for typical applications by the manufacturer is 2 to 12 oz/cwt. The manufacturer stated that for special cases dosages up to 20 oz/cwt have been used.

Throughout the development of the trial batch concrete mixtures, the consistency of the fresh concrete became a concern. In some cases, the point of concern was how stiff the mixture was and its lack of flowability. To help mitigate this issue, the HRWR dosage was altered. Small

scale trial batches were conducted to analyze the effects of HRWR dosage on workability of fresh concrete. A measurement similar to the slump measurements specified in ASTM C143 were used to assess the workability of these small scale concrete mixture batches. The higher the “slump” value, the greater the flowability. As shown in Figure 3-12, the original HRWR dosage of 12.2 oz./cwt yielded a “slump” of zero inches. The HRWR dosage was increased to find the optimal dosage in terms of workability, more specifically, flowability. As seen in Figure 3-12, the “slump” value peaked at a dosage of 16 oz./cwt; therefore, this dosage was used in subsequent trial batch concrete mixtures. Details regarding the “slump” readings taken and the procedure used to mix the small-scale trial batches can be found in Section 4.4.

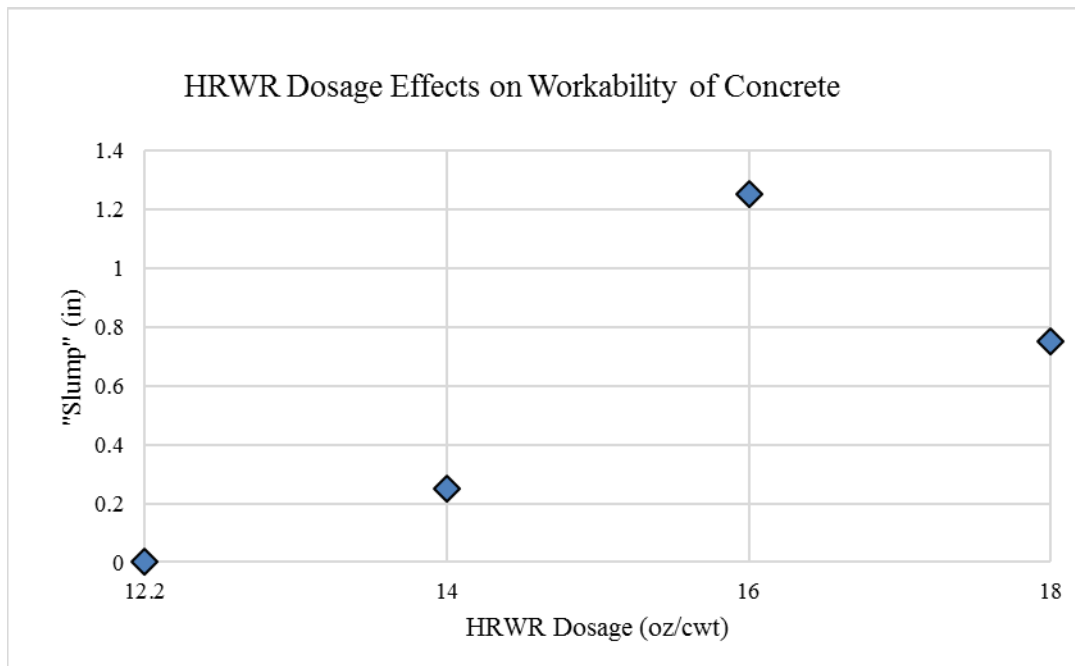

Figure 3-12: HRWR Dosage Effects on the Workability of Concrete

### **3.3.1.5.2 Accelerating Admixture**

Accelerating admixtures were not used in most trial batch concrete mixtures. As discussed in Section 2.1.4.3 of the literature review, accelerating admixtures have shown to cause increased drying shrinkage in concrete mixtures. So, although the accelerating admixtures will help to reach the high-early strength goal of this research project, it could negatively impact durability through increased shrinkage. Therefore, the strength goals were reached mostly through proportioning of the concrete mixtures and through the use of a HRWR admixture.

For reasons that will be discussed in Section 3.3.1.6, there were two trial batch concrete mixtures where accelerating admixture was used. For both of these cases, two-thirds of the maximum dosage recommended by the manufacturer was used as the dosage. The basis for this dosage was a study performed by Rear and Chin (1990) where early compressive strengths were evaluated for various types of cement, fly ash and accelerating admixtures. The peak early compressive strength most commonly occurred with an accelerating admixture dosage equal to two-thirds the maximum dosage recommended by the manufacturer.

### ***3.3.1.6 Determining Selected Concrete Mixtures***

In this subsection, the iterative process used to develop and establish the two trial batch concrete mixtures is discussed. These two mixtures were selected as the concrete mixtures that will undergo further testing planned for this research project. These concrete mixtures were selected based on their strength and constructability performance. This selection process is depicted in Figure 3-1. The proportions used to develop trial batch concrete mixtures based on the maximum compaction of aggregates method are shown in Table 3-5. The compressive strength values reported in this table are the average values from all compressive strength testing performed on the concrete mixture throughout this research project. In the consistency column of

Table 3-5, a check mark denotes acceptable consistency and an ex mark denotes unacceptable consistency for reasons that will be discussed later in this section. A more extensive reporting on compressive strength, slump/spread and set time are provided in Chapter 5.

The first trial batch concrete mixture to be mixed and tested was MIX 1 using the previously discussed starting points, where 1/2" coarse aggregate was used along with a w/cm ratio equal to 0.26 and a  $V_{\text{paste}}/V_{\text{voids}}$  ratio equal to 1.75 and there was no fly ash used in this mix. As seen in Table 3-5, the 12-hour compressive strength was 5860 psi, exceeding the target of 4000 psi, but the consistency of this mix was very stiff and thick, as seen in Figure 3-13, making it difficult to cast the concrete into cylinder molds. The slump of MIX 1 was only equal to approximately 2 inches. Since fly ash has shown to improve the workability of fresh concrete and the ultimate goal is for the concrete mixtures to contain fly ash, MIX 2, MIX 3 and MIX 4 were evaluated. These trial batch concrete mixtures contained 15, 20 and 25% Class F fly ash replacement, respectively. Even though fly ash has also shown to decrease strength, it was not a concern because MIX 1 significantly exceeded the target 12-hour compressive strength. These trial batch concrete mixtures also reached the target 12-hour compressive strength, but the consistency remained stiff and thick and the slump value did not increase, causing the concrete to have poor constructability.



Figure 3-13: MIX 1 Thick Consistency Shown in Wheelbarrow and in Compression Strength Molds

The next approach taken to improve the consistency of the concrete was to increase the w/cm ratio. Using the w/cm ratio table from ACI 211.4R shown in Figure 3-5, it was estimated that the compressive strength would decrease 1000 psi with every 0.03 increase in the w/cm. Since MIX 1 was approximately 2000 psi over the target strength, the w/cm could be increased by an estimated 0.06. Therefore, the next trial batch concrete mixtures evaluated were MIX 9, MIX 10, MIX 11 and MIX 12 with a w/cm ratio equal to 0.32. These were comprised of the same proportions as MIX 1 to MIX 4, with the exception of the increased w/cm. Of these four trial batch concrete mixtures, MIX 9, the one containing no fly ash, was the only to reach the target compressive strength of 4000 psi in 12 hours. The other three of these trial batch concrete mixtures, containing 15, 20 and 25% Class F fly ash did not reach the target strength by more than 1000 psi. Also, MIX 9, MIX 10, MIX 11 and MIX 12 each experienced segregation. An example of segregated fresh concrete is shown in Figure 3-14. Segregation in fresh concrete is characterized by coarse aggregates settling to the bottom and a thin paste is left on top. Segregation is at the other end of the spectrum in terms of consistency, when compared to MIX 1

through MIX 4 which had stiff consistencies. The segregation that occurred with these trial batches could have also contributed to their reduced compressive strength.



Figure 3-14: MIX 11 in Wheelbarrow Showing Segregation with Thin Paste on Top and Aggregates Being Scooped up from the Bottom

At this point, Class C fly ash was tried as a replacement for Class F fly ash in MIX 11. Although, Class C fly ash is not readily available in New England, if the results were significantly improved with the use of Class C fly ash, the benefits could have outweighed the cost of transporting the material; therefore, the use of Class C fly ash was considered as an option. As mentioned in Section 2.1.3.1 of the literature review, Class C fly typically has a higher rate of reaction at early ages than Class F fly ash, resulting in higher early strength in concrete containing Class C fly ash. Class C fly ash is typically used to replace 20 to 35% of cement.

The replacement percentage was chosen to be 20%, the low-end value. A lower replacement percentage was chosen with the intent of not decreasing the compressive strength of

MIX 9 greatly. As shown in Table 3-5, this trial batch concrete mixture, MIX 11-C, did not reach the target strength of 4000 psi in 12 hours and also segregated.

To achieve desired compressive strength and consistency properties, which lie between the results obtained with MIX 1 through MIX 4 and MIX 9 through MIX 11, a w/cm ratio equal to 0.29, exactly at midpoint between the two sets of trial batch concrete mixtures, was chosen to evaluate next, using Class F fly ash. MIX 5 through MIX 8, shown in Table 3-5, were the next trial batch concrete mixtures to be tested for strength and constructability. These trial batches have the same proportions as MIX 1 to MIX 4 and MIX 9 to MIX 12 except for the w/cm ratio, which is equal to 0.29. The trial batch concrete mixture of this group that did not contain fly ash, MIX 5, reached 4390 psi in 12 hours, exceeding the target strength. MIX 5 also had acceptable consistency. An acceptable consistency was defined as a fresh concrete that has adequate constructability and workability. An adequate constructability and workability means that the slump is greater than or equal to 3 inches without any segregation occurring between cement paste and coarse aggregates.

The definition of adequate workability and constructability will be modified as it is developed throughout the project. In this case, and for most of the trial batch concrete mixtures in this research project, an acceptable consistency means that the fresh concrete had workability properties similar to that of self-consolidating concrete. Self-consolidating concrete is very fluid but without any segregation and typically does not require any vibrating to be consolidated within a mold or formwork. An example of fresh concrete with an acceptable consistency can be seen in Figure 3-15. The trial batch concrete mixture of this group that contained 15% fly ash replacement, MIX 6, achieved a compressive strength of 3880 psi in 12 hours, which was only slightly under the target of 4000 psi and had an acceptable consistency. MIX 7 and MIX 8, which contained 20 and 25% fly ash replacement, respectively, achieved 12-hour compressive strength

well under the target. The consistency of MIX 7 was acceptable, where it was fluid enough without segregation occurring but segregation occurred with MIX 8 causing the consistency to be unacceptable.



Figure 3-15: Concrete Mix with Acceptable Consistency

As seen in Table 3-5, Class C fly ash was used as a partial cement replacement in MIX 7 in the place of Class F fly ash. The use of Class C fly ash was again explored using a 20% cement replacement. This replacement percentage was used again since the trial batch concrete mixtures in this group (MIX 5 – MIX 8) were not meeting the target compressive strength and it has been shown that higher fly ash percentages lead to lower compressive strength values. A 20% fly ash replacement is the lowest percentage typically used with Class C fly ash so this was the percentage chosen. The compressive strength and consistency did not show any improvement with the use of Class C fly ash in the trial batch concrete mixture, MIX 7-C. Class C fly ash was no longer considered as an option in this research project since it did not achieve significantly



different results from Class F fly ash in two different trial batch concrete mixtures, MIX 11-C and MIX 7-C.

Since the use of Class C fly ash did not increase the strength of MIX 7, accelerating admixture was added to MIX 7 in an attempt to increase the compressive strength reached in 12 hours. This is represented as MIX 7-A in Table 3-5. As shown, MIX 7-A did not demonstrate a significant enough increase in strength to meet the target. The 12-hour compressive strength only increased by 29% with the use of accelerating admixture and was still 28% lower than the target 12-hour compressive strength.

Of the previously discussed group of trial batch concrete mixtures, MIX 5 – MIX 8, including MIX 7-C and MIX 7-A, there were two mixes which yielded promising results: MIX 5 and MIX 6. MIX 5 reached the target strength in 12 hours and had an acceptable consistency. Although this trial batch concrete mixture reached the strength and constructability goals, there is a concern for long-term durability since it did not contain any fly ash to mitigate shrinkage. Fly ash is an essential part of the concrete mixture when considering durability and the potential for drying shrinkage to occur in the concrete. MIX 6 also yielded promising results with a 12-hour compressive strength only 3% under the target 12-hour strength. MIX 6 also had an acceptable consistency and incorporated a 15% fly ash replacement.

Although these trial batch concrete mixtures (MIX 5 and MIX 6) achieved promising results, further trial batch concrete mixtures were evaluated to explore the use of different coarse aggregate sizes and  $V_{\text{paste}}/V_{\text{voids}}$  ratios.

The use of 3/8" coarse aggregate was explored using the same  $V_{\text{paste}}/V_{\text{voids}}$  as the previously discussed trial batch concrete mixtures, 1.75, a w/cm ratio of 0.29 and a fly ash replacement value of 20%. This trial batch concrete mixture, labeled MIX 13, had the same

proportions as MIX 7 other than the coarse aggregate size. The change in coarse aggregate size was considered with the goal of yielding a higher 12-hour compressive strength value. As seen in Table 3-5, the compressive strength increase with the change in aggregate size exceeded the target compressive strength at 12 hours, reaching 4490 psi. But, the consistency of this mix became very stiff; therefore, this trial batch concrete mixture was not acceptable. At this point the fly ash replacement percentage was increased to 25%, hoping to improve the consistency of the fresh concrete with the risk of compromising some compressive strength. The fresh concrete consistency did improve, but the strength dropped significantly, putting it below the target strength. The 12-hour compressive strength of MIX 14 was only 3050 psi, 24% under the target 12-hour compressive strength.

An accelerating admixture was added to MIX 14, creating MIX 14-A. Trial batch concrete mixture MIX 14-A did not achieve a higher 12-hour compressive strength than MIX 14; it achieved a lower 12-hour compressive strength equal to 2660 psi. This result did not seem accurate, so this trial batch concrete mixture was mixed and tested several times, achieving similar results each time. It was considered that the accelerating admixture could have come from a bad batch or expired before the expiration date provided. Therefore, a new container of accelerating admixture was obtained to be used for retesting of the concrete mixture, but it did not affect the results. It is possible that with mixing concrete at such a small scale and with a high cement content that the accelerating admixture was not effective. It is also possible that at large scale, use of an accelerating admixture would improve the 12-hour compressive strength results of this trial batch concrete mixture. Accelerating admixture was not considered any further for this research project due to the unpredictable results, where the strength decreases with accelerating admixtures.

The next trial batch concrete mixtures that were evaluated were MIX 15 and MIX 17. Each of these trial batch concrete mixtures had a w/cm ratio of 0.29, a coarse aggregate size of 1/2" and a fly ash replacement equal to 15%. These proportions were chosen since they were similar to MIX 6, which yielded the most promising results thus far. The proportion that makes MIX 15 and MIX 17 different from MIX 6 is the  $V_{\text{paste}}/V_{\text{voids}}$  ratio. MIX 15 has a  $V_{\text{paste}}/V_{\text{voids}}$  ratio equal to 1.50 and MIX 17 has a  $V_{\text{paste}}/V_{\text{voids}}$  ratio equal to 1.25, as shown in Table 3-5. MIX 15 reached a strength slightly lower than MIX 6, and, therefore, lower than the 12-hour target compressive strength. MIX 15 reached a compressive strength of 3810 psi in 12 hours, which is about 5% lower than the desired 4000 psi compressive strength. MIX 15 proportions yielded an acceptable fresh concrete consistency. Similar to MIX 15, MIX 17 was also under the 12-hour target compressive strength, but reached the same 12-hour compressive strength as MIX 6, so it was only 3% less than the target compressive strength. Dissimilar to MIX 15, MIX 17 had a consistency that was too stiff, causing it to be unacceptable.

A combination of two coarse aggregate sizes was used next to evaluate the effects this change had on the compressive strength and constructability of trial batch concrete mixtures. The combination of 1/2" and 3/8" coarse aggregates was used in MIX 16 and MIX 18, as shown in Table 3-5. The proportions of MIX 16 were the same as MIX 15 other than the addition of 3/8" coarse aggregate. Similarly, MIX 18 had the same proportions as MIX 17 other than the addition of 3/8" coarse aggregate. Both MIX 16 and MIX 18 proportions produced a trial batch concrete mixture with a stiff consistency, so they were considered unacceptable. MIX 16 and MIX 18 also yielded 12-hour compressive strengths that were unacceptable, since they were under the 4000 psi target.

As shown in Figure 3-1, after assessing trial batch concrete mixtures for their strength and constructability properties, two mixtures were to be selected for further testing on durability

properties. As previously mentioned in this section, MIX 6 yielded promising results with a 12-hour strength only 3% under the target compressive strength to be reached in 12 hours and had an acceptable consistency. This result confirmed adequate strength and constructability. Of the trial batch concrete mixtures explored using various coarse aggregate sizes and  $V_{\text{paste}}/V_{\text{voids}}$  ratios, there was one that achieved acceptable strength and constructability results. MIX 15 achieved a compressive strength equal to 3810 in 12 hours and had an acceptable consistency with a slump equal to 4 inches. This compressive strength was only 5% under the target compressive strength of 4000 psi 12 hours. It should also be noted that all trial batch concrete mixtures exhibited an initial set time of at least 5 hours. This vastly exceeds the desired workability time presented in Table 2-2: Key Performance Features of ABC Closure Pour Concrete Collected Compiled from Surveys of 30 to 90 minutes.

The results achieved by trial batch concrete mixtures, MIX 15 and 6, provided the most promising strength and constructability properties for the concrete application defined by this research project. For this reason, MIX 6 and MIX 15 were the two selected concrete mixtures to undergo further testing to assess the durability properties of each concrete mixture. The results from further testing of these two selected concrete mixtures can be found in Section 5. All trial batch concrete mixtures designs, including MIX 6 and MIX 15, are presented in quantities per cubic yard in Appendix B.

Table 3-5: Trial Batch Concrete Mixtures Developed using the Maximum Compaction of Aggregates Method with Reported Compressive Strengths and Consistency of Concrete

MIX ID	Vpaste/Vvoids	Coarse Aggregate Size	W/CM Ratio	Fly Ash Replacement	12-Hour Compressive Strength (psi)	Consistency
1	1.75	1/2"	0.26	0%	5860	✗ Stiff/Thick
2				15%	5200	
3				20%	4320	
4				25%	4750	
5			0.29	0%	4390	✓
6				15%	3880	
7				20%	2070	
7-C*					2860	
7-A**			0.32	2910	✗ Segregation	
8				25%		1050
9			0.32	0%		4880
10				15%		2890
11		20%		2680		
11-C*				1910		
12		25%	940			
13		3/8"	0.29	20%	4490	✗ Stiff/Thick
14				25%	3050	
14-A**				2660	✓	
15	1.50	1/2"	0.29	15%	3810	✗ Stiff/Thick
16	3/8" & 1/2"	3620				
17	1.25	1/2"			3880	
18	3/8" & 1/2"	3470				
*C: Class C Fly Ash was Used in Place of Class F **A: Accelerating Admixture was Used				Green = Target Strength Reached Yellow = Within 1000 psi of Target Strength Red = More than 1000 psi Below Target Strength		

### 3.3.1.1 Alterations to Selected Concrete Mixtures

Once further testing began on the two selected concrete mixtures, variability in results was observed, as discussed in Section 5. One property that was variable throughout mixing and testing of concrete mixtures was the consistency of the fresh concrete. The two selected concrete mixtures, MIX 6 and MIX 15, yielded some results where the consistency was too thick and stiff.

To mitigate this concern, a study was conducted on the HRWR dosage, as discussed in Section 3.3.1.5.1. Based on the results found from this study, the HRWR dosage was changed to the optimal dosage found for increasing the flowability of the fresh concrete, which was 16 oz./cwt. As shown in Table 3-6, the change in HRWR dosage is denoted by “HD”, creating MIX 6-HD and MIX 15-HD. The 12-hour compressive strength results were not significantly affected by the change in HRWR dosage. The slump/spread results were improved with the change in the HRWR dosage, which can be seen in Section 5.2.1 of the results section.

The compressive strength was also variable throughout mixing and testing of the two selected concrete mixtures. The 12-hour compressive strength values shown for MIX 6, MIX 6-HD, MIX 15 and MIX 15-HD in Table 3-6 are the average values from all 12-hour compressive strengths recorded for each concrete mixture throughout this entire research project. This means that some of the 12-hour compressive strengths exceeded the 4000 psi target, but others were as much as 34% under the target. Although the variability was greatly reduced throughout the project, as discussed in Section 5.1.1, these concrete mixtures still had some 12-hour compressive strengths under 4000 psi.

Possibilities of increasing compressive strength other than altering the concrete mixture design were considered. Heat curing was implemented as a way of increasing the compressive strength reached in 12 hours. All compressive strength specimens were cured at 80°F up until this point. The curing temperature of MIX 6-HD and MIX 15-HD compressive strength specimens was increased to 110°F for select trial batches. The trial batches that were heat cured as labeled as MIX 6-HD-H and MIX 15-HD-H. As shown in Table 3-6, MIX 6-HD-H reached a compressive strength 5140 psi in 12 hours, exceeding the target strength about 30%, and MIX 15-HD-H reached a compressive strength of 5200 psi in 12 hours, also exceeding the target strength by about 30%. Heat curing proved to be a successful way of increasing the compressive strength

achieved in 12 hours of curing. By curing the concrete specimens at 110°F, the compressive strength reached in 12 hours was significantly higher than the target compressive strength of 4000 psi. Therefore, to guarantee the target strength is reached, curing blankets could be used in the field to heat the concrete above 80°F for 12 hours during the curing period.

Table 3-6: Trial Batch Mixtures Measuring the Effects of HRWR Dosage and Increased Curing Temperature on the Selected Mixture Designs

MIX ID	High-Range Water Reducer Dosage (oz./cwt)	Curing Temperature (°F)	12-Hour Compressive Strength (psi)	Consistency
6	12.2	80	3880	✓
15			3810	
6-HD <sup>1</sup>	3840			
15-HD <sup>1</sup>	3820			
6-HD-H <sup>2</sup>	16	110	5140	
15-HD-H <sup>2</sup>			5200	
1 - HD: HRWR Dosage was increased to 16 oz./cwt 2 - H: Heat Cured at 110°F				

## 4 LABORATORY TESTING AND PROCEDURES

### 4.1 Preparation and Storage of Materials

All materials used for the research project were stored in the UMass, Amherst Gunness Structural Engineering Laboratory (Gunness Lab) after receiving them. The following section will describe the care and/or special preparation required for each of the materials used.

The ASTM Type III cement used for this project was stored in the Gunness Lab at laboratory temperature and humidity. The cement bags were stored on top of a wood pallet, covered in a layer of plastic and kept away from heaters, windows and water to avoid extreme changes in temperature and humidity.

Both the coarse and fine aggregates were stored in sealed 32-gallon plastic barrels in the Gunness Lab, also at temperature and humidity conditions in the laboratory. Prior to mixing each batch of concrete in the laboratory, the coarse and fine aggregates were oven dried and then brought to a saturated surface-dry (SSD) condition. The aggregates were dried by placing them in an oven heated to 230°F for 24-hours. The aggregates were then allowed to cool to room temperature for at least 24-hours. This process was followed to ensure the aggregates to be completely dry and the aggregate temperature to be ambient. The absorption capacity was determined for each aggregate size from each aggregate source, as stated in section 4.3 Aggregate Testing Procedures. The amount of additional water required to bring the aggregates to SSD condition was found using the absorption capacity of each aggregate type. This additional water was required to fill aggregate pores and to allow the aggregates to reach saturated surface dry conditions without taking from or contributing to water required to hydrate the cementitious materials.



All fly ash was stored in the Guinness Lab in sealed plastic 5-gallon pails at laboratory temperature and humidity conditions. The pails were kept on top of a wood pallet and kept away from heat sources.

Tap water was used as mixing water used for all concrete batches. The water temperature was measured during mixing of concrete batches and it ranged from 65 to 75°F.

All chemical admixtures were stored in the original shipping containers in the lab. The containers were all sealed plastic pails, and depending on the manufacturer and time of shipping, these containers varied in volume from 3.5 gallons to 5 gallons.

#### **4.2 Mixing Procedure**

All concrete batches were mixed at the University of Massachusetts, Amherst Guinness Structural Engineering Lab. Mixing of concrete was performed in accordance with ASTM Standard C192: *Standard Practice for Making and Curing Concrete Test Specimens in the Laboratory*. A STOW Model CM6 concrete mixer, with a capacity of 6 cubic feet (165 liters) was used to mix all machine mixed concrete batches. The first concrete batches, which are not reported in the previous section, were approximately 0.27 cubic feet in volume. This volume was too small to be mixed in the concrete mixer, and, therefore, were mixed by hand in a 25.75" x 17.75" x 3.5" round edged aluminum pan. Adequate mixing was not able to be obtained using this method, due to the high cement content. The concrete became very clumpy and dry to the point that the concrete could not be cast in molds for testing; therefore, this hand mixing method was discontinued and larger volumes were mixed. Since the machine mixing procedure proved favorable, it was used for all subsequent trial batches, and all trial batches reported from this research project are only those mixed using the concrete mixer.

Prior to each concrete batch mixed using the concrete mixer, the mixer was dampened to reduce the amount of water absorbed by residue adhered to the walls of the mixer barrel. The small concrete residue in the barrel appeared to be absorbing water, and potentially causing variability in the amount of available mixing water, which particularly affected the small volumes of concrete being mixed. The procedure used to dampen the machine mixer was first, filling the barrel completely with water 12-24 hours before it was used to mix concrete. Then, immediately before the machine mixer was used, the water was emptied and the barrel was flipped upside-down for approximately 10-15 minutes to allow excess water to drain.

The order that the concrete constituents were added to the machine mixer was based upon ASTM Standard C192 and individual chemical admixture manufacturer recommendations. The mixing water required for a pour was separated into two portions, equal to 25% and 75% of the total mixing water. The 75% portion of mixing water was kept as plain mixing water. High-range water reducer (HRWR) chemical admixture was added to the 25% portion of mixing water. The reason for this separation was to add the HRWR chemical admixture as directed by the manufacturer for optimal performance. It was also found that by mixing the HRWR in the full amount of water, it was difficult to sufficiently mix it into the water and there was HRWR found settled in the bottom of the pail after pouring the solution into the mixer. The HRWR chemical admixture is recommended by the manufacturer to be added at the end of the batch sequence and to be dispersed within a small portion of the mixing water. The exact 75% and 25% portions were chosen subjectively, but kept consistent throughout the duration of this research project.

Before the concrete mixer was started, coarse and fine aggregates were added after being weighed for the specific volume required. The mixer was then started, and the aggregates were mixed together until a homogeneous mixture was formed. The remaining constituents were then added in the following order: cement, fly ash (if used), pure mixing water and mixing water

containing HRWR chemical admixture. If any chemical admixtures in addition to HRWR were used, they were added in the first portion of mixing water. They were added at this time to keep the chemical admixtures separate, as recommended by the chemical admixture manufacturers. Each of the constituents were added to the concrete mixer using 5-gallon plastic pails, as shown in Figure 4-1.



Figure 4-1: Measured Concrete Constituents Before Mixing

After all constituents were added to the mixer, the concrete was mixed for 3 minutes, followed by a 3-minute rest period, followed by a 2-minute final mixing period, as indicated in ASTM C192. During the rest period, the mixer barrel opening was covered with a layer of plastic to prevent any evaporation from occurring, as shown in Figure 4-3. At the end of the entire mixing cycle, the concrete was poured into a wheelbarrow, as shown in Figure 4-2, and brought into the laboratory where the fresh concrete tests were performed, measuring air content and spread or slump. At this time, the concrete mixture was also cast into cylindrical molds to subsequently conduct standard compression tests of hardened concrete. Any other specimens required from the concrete mixture were also cast at this time, such as ring shrinkage and bar pullout specimens.



Figure 4-2: Removal of Concrete from the Machine Mixer in Preparation for Testing and Casting



Figure 4-3: Concrete Batch in Machine Mixer during Rest Period with the Plastic Cover

#### 4.3 Aggregate Testing Procedures

Aggregate testing was conducted for coarse and fine aggregate provided by Source 1 and Source 2 as described in Section 3.2.1: Aggregates.

### 4.3.1 Gradation Curves

The particle size distribution was found for coarse and fine aggregates in accordance with ASTM Standard C136: *Standard Test Method for Sieve Analysis of Fine and Coarse Aggregates*. The sieve analyses were performed on oven-dried samples, where the aggregates were dried at 230°F for 24-hours prior to testing. The sieve sizes chosen for the analysis can be seen in Table 4-1. The sample sizes chosen for each aggregate size were in accordance with ASTM C136. The aggregate samples were shaken using a Humboldt mechanical sieve shaker for 5 minutes. The aggregates from each sieve were weighed, following the shaking, and gradation curves were constructed. The average of two sieve analyses were used to create the gradation curves, shown in Appendix A.

Table 4-1: Sieve Sizes Chosen for Determining Aggregate Gradation

Coarse Aggregate Sieve Order	Fine Aggregate Sieve Order
1"	#4
3/4"	#8
1/2"	#14
3/8"	#30
#4	#50
#8	#100
Pan	#200
	Pan

### 4.3.2 Bulk Density and Voids

The bulk density and percent voids of each aggregate size from each aggregate source was measured and are reported in section 3.2.1 Aggregates. *ASTM Standard C29: Standard Test*

*Method for Bulk Density (“Unit Weight”) and Voids in Aggregate* was used to find the bulk density and percent voids. To find the percent voids, the absorption was required, which was determined as described in Section 4.3.3. Both the loose and rodded bulk densities were found. The bulk densities were found for oven-dried samples, where the aggregates were dried at 230°F for 24-hours prior to testing.

### **4.3.3 Density, Relative Density and Absorption**

The relative density (specific gravity), apparent relative density (apparent specific gravity), density, apparent density and absorption were measured for each aggregate size from each aggregate source for both oven dried and saturated surface dried conditions. For coarse aggregates, *ASTM Standard 127: Standard Test Method for Density, Relative Density (Specific Gravity), and Absorption of Coarse Aggregate* was followed; similarly, for fine aggregates, *ASTM Standard 128: Standard Test Method for Density, Relative Density (Specific Gravity), and Absorption of Fine Aggregate* was followed.

## **4.4 High Range Water Reducing Admixture Dosage Analysis**

As discussed in Section 3, it was necessary to determine the dosage of high-range water reducing (HRWR) chemical admixture for optimal flowability of the concrete mixture. This was achieved by mixing small-scale batches of a concrete mixture, MIX 6, as defined in Section 3.3.1. Although mixing the batches by hand yielded different results than were achieved with the concrete mixer, the dosage evaluation was comparative, so the optimal dosage was able to be determined. Various dosages of HRWR were added to each of the concrete mixture, as later discussed. All proportions were kept constant, which required the mixing water to be adjusted based on the water added through the HRWR, as done with all trial batches. This was calculated using the water content of the HRWR.

For each small-scale trial batch, the concrete was mixed by hand with a scoop and a bowl, as shown in Figure 4-4. Once mixed, the concrete mixture was scooped into a Humboldt H-3638 funnel, which is typically used as a funnel for slump tests. For this analysis, the funnel was used as the slump cone in order to reduce the volume required of each batch. By reducing the batch size, they were able to be mixed by hand. The “slump” readings taken from this analysis were only used as a comparative measure between the small-scale batches. The total volume mixed per small-scale batch was 0.135 cubic feet. This was the volume required to fill the funnel.



Figure 4-4: Concrete Hand-Mixed for HRWR Dosage Analysis Small-Scale Trial Batches

The funnel was held down by steel plates to prevent any uplift from occurring while it was being filled, as seen in Figure 4-5. The funnel was filled in two layers and rodded 25 times per layer. Once filled, a trowel was used to finish the top surface of the concrete. As this point, a process similar to that described in ASTM Standard C143 for lifting the slump cone was used to lift the funnel. A steady upward lift was used to remove the funnel, and the funnel was lifted the full distance in approximately 5 seconds. The “slump” reading was then taken, as shown in Figure 4-6, similar to an actual slump reading.



Figure 4-5: Slump Test Setup Performed on the Small-Scale Trial Batches for the HRWR Dosage Analysis



Figure 4-6: Slump Measurement Being Taken on Concrete Containing a HRWR Dosage of 16 oz./cwt



This procedure was followed for each HRWR dosage that was evaluated. The first dosage evaluated was 12.2 oz./cwt. This was the current dosage used in concrete mixtures when this dosage analysis was performed. HRWR dosages equal to 14, 16 and 18 oz./cwt were also analyzed. Results from this procedure can be found in Section 3.3.1.5.1.

## **4.5 Concrete Testing Procedures**

This section will describe the concrete testing procedures used in the laboratory for both fresh and hardened concrete.

### **4.5.1 Strength**

#### **4.5.1.1 *Compressive Strength***

To test compressive strength of the concrete mixtures, ASTM Standard C39: *Standard Test Method for Compressive Strength of Cylindrical Concrete Specimens* was followed. Three cylindrical specimens were cast to determine compressive strength at each selected testing time (i.e. 3 – 12-hour strength specimens, 3 – 24-hour strength specimens, etc.). Standard cylindrical plastic molds, as shown in Figure 4-7, with a diameter of 4 inches and a height of 8 inches were used. To fill the molds, concrete was poured in 2 layers, and each layer was rodded with a tamping rod 25 times to consolidate the concrete. Once the cylindrical mold was filled, the outside of the mold was gently tapped with the tamping rod to remove any air pockets formed by rodding and to work excess air voids to the top. The cylindrical specimens were then cured in a Thermocure II Concrete Curing Box that kept the specimens at 100% relative humidity and 80°F, with the exception of MIX 23-16-H and MIX 35-16-H, where the temperature of the curing tank was set to 110°F, as shown in Table 3-6. The cylinders remained in the plastic mold until the time of testing. Every concrete mixture was tested for compressive strength at 12 hours and 24 hours. Additional tests at 18 hours, 7 days and 28 days were performed for various concrete mixtures as

discussed in Section 5 in order to understand later strength gains that occurred in the concrete mixtures. The compressive strength of each cylindrical specimen was tested using a FX500 Forney Compression Testing Machine. The cylinders were tested to failure to find the ultimate compressive strength values. The load was applied at a loading rate of  $35 \pm 7$  psi/sec during the latter half of the anticipated loading phase. During the first half of the anticipated loading phase, a higher rate of loading was used. The higher loading rate was applied in a controlled manner as to not subject the specimen to shock, as specified in ASTM C39. The average of the three cylindrical specimens was taken to be the compressive strength at the specified test age.



Figure 4-7: Cylindrical Mold

## 4.5.2 Constructability

### 4.5.2.1 *Slump/Spread*

Either a slump or spread test was performed on every concrete batch depending on qualitatively observing the flowability in each concrete mixture as it was being mixed. These tests were performed while the concrete was in a fresh state, immediately following the final mixing period. If the concrete was flowable and had a consistency similar to that of a self-consolidating concrete, a

spread test was performed. Alternatively, if the concrete had the consistency of a normal concrete, or had a dense consistency, a slump test was performed. Slump tests were performed in accordance with *ASTM Standard 143: Standard Test for Slump of Hydraulic-Cement Concrete*, and spread tests were performed in accordance with *ASTM Standard C1611: Standard Test Method for Slump Flow of Self-Consolidating Concrete*, using procedure B, the inverted mold, for the mold filling method. A Humboldt slump cone was employed for both the slump and spread test. The base used for the spread test was a 4-foot by 4-foot sheet of plywood covered in a double layer of 6 mil plastic to create a flat, level, nonabsorbent surface. Pictures illustrating each of the tests can be seen in Figure 4-8 and in Figure 4-9.



Figure 4-8: Measuring the Slump of a Concrete Mixture



Figure 4-9: Lifting of Spread Test Mold and Measuring of the Resulting Circular Spread of Concrete

#### 4.5.2.2 Set Time

The initial and final set time of the concrete mixtures were determined using ASTM Standard 403: *Standard Test Method for Time of Setting of Concrete Mixtures by Penetration Resistance*. The standard specifies that this test be performed on mortar sieved from the concrete mixture, rather than a prepared mortar. The concrete was mixed as described in Section 4.2 and using a No.4 sieve, coarse aggregates were separated from the concrete, as shown in

, and a mortar sample was formed. The containers used for the mortar specimens were fabricated from 6-inch by 12-inch plastic cylindrical molds. The plastic cylindrical molds were cut from the original height of 12 inches to a height of 6.25 inches to be used for this test, as displayed in

Figure 4-12. For each trial batch where the set time was measured, 3 plastic cylindrical molds were filled with mortar. The mortar was cured in a Thermocure II Concrete Curing Box, which kept the specimens at 100% relative humidity and 80°F. The penetration resistance was measure as specified in the ASTM C403 using a Humboldt Acme Penetrometer, depicted in Figure 4-10. As the resistance increased, smaller penetrometer needles were used. The initial and final set times were established when the penetration resistance reached 500 psi and 4000 psi, respectively.



Figure 4-10: Acme Penetrometer Used to Measure Initial and Final Set Time of Concrete Mixtures & Various Penetrometer Needle Sizes



Figure 4-11: Sieving Coarse Aggregates out of Concrete to Form Mortar for Set Time Test



Figure 4-12: Plastic Cylindrical Mold Cut to be used for Set Time Penetrometer Tests

## 4.5.1 Durability

### 4.5.1.1 Air Content

Air content was measured for concrete mixtures after the final mixing period. *ASTM Standard C231: Standard Test Method for Air Content of Freshly Mixed Concrete by the Pressure Method* was followed for this testing. A Type-B Meter (Forney model H-2786) was used, as depicted in Figure 4-13.



Figure 4-13: Water Injected Through Petcock of Type-B Meter for Air Content Test

### 4.5.1.2 Confined Shrinkage

The confined shrinkage ring test was performed in accordance with AASHTO PP 34-99 (2005): *Standard Practice for Estimating the Cracking Tendency of Concrete*. This standard was chosen over the *ASTM Standard 1581: Standard Test Method for Determining Age at Cracking*

*and Induced Tensile Stress Characteristics of Mortar and Concrete under Restrained Shrinkage*

because the materials required to construct the test setup for the AASHTO Standard were more readily available than those required of the ASTM Standard. The two standards are very similar with the most significant difference being the dimensions of the ring. Because the AASHTO concrete ring has a larger thickness, it typically takes longer for shrinkage cracking to occur. Since this test is intended to compare shrinkage of different concrete mixtures, the change of time to cracking between standards does not affect conclusions of results as long as the same apparatus is used for all tests. The formwork for this test setup can be seen in Figure 4-14. This formwork was used to fabricate a concrete ring that is 6 inches high with an inside diameter of 12.75 inches and an outside diameter of 18 inches. The inner steel ring is a 12-inch structural steel pipe with an outside diameter of 12.75 inches and a wall thickness of 0.5 inches cut to 6-inch lengths. The inner and out surfaces of the steel pipe are machined to a smooth, polished finish. The outer surface of the concrete ring was formed by using an 18" (inner diameter) Sonotube, also cut to 6-inch lengths. The base of the formwork is a 2-foot by 2-foot piece of 3/4" plywood. To create the specified nonabsorbent finish with reduced friction, the plywood base and interior surface of the Sonotube ring were finished with polyurethane. The finishing process entailed several coats of polyurethane, sanding between each coat until the surface was smooth and completely sealed.

The tiedown system utilized for this test was a series of 4-inch corner braces with slotted holes. The corner braces included circular holes as purchased, but the slotted holes were fabricated in a machine shop after purchasing the corner braces. The corner braces on the interior side of the concrete ring were extended towards the steel ring and screwed tight during casting and until the recording of strains began. The same corner braces were used on the exterior of the concrete ring. The exterior braces were extended towards the Sonotube ring and screwed tight during casting. A bead of silicone caulking was used to seal the seam between the Sonotube ring



and the plywood base during casting of concrete to prevent any concrete from seeping out of the bottom.

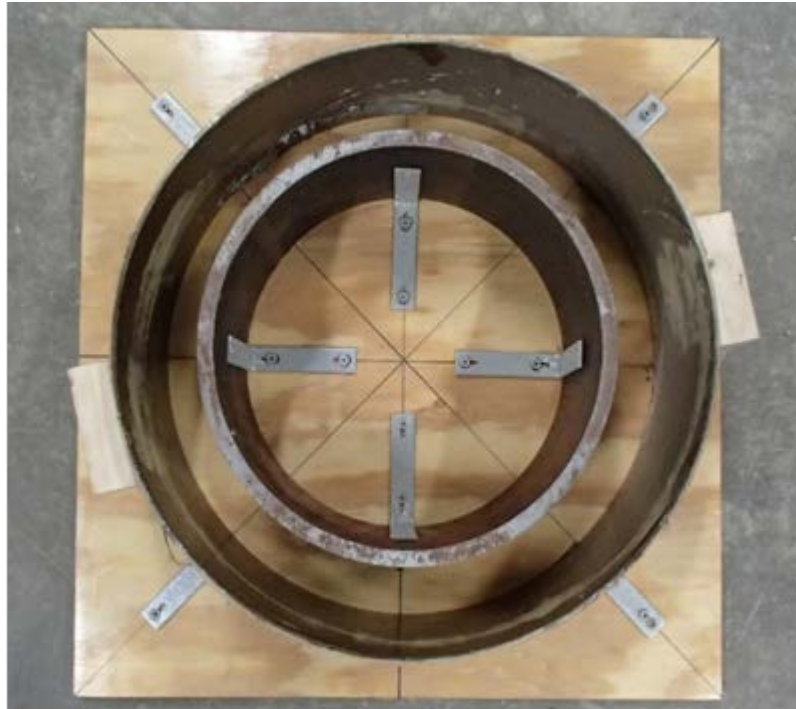

Figure 4-14: Formwork for Shrinkage Ring Test Setup

The procedure specified in AASHTO Standard PP34-99 was followed for casting the concrete into the formwork. The concrete was poured in 3 layers, and rodded 75 times per layer. A rubber mallet was used to tap the base of the setup during casting and close any holes left by rodding and to release large air bubbles. A vibrator was used only on concrete mixtures that had a very thick consistency and were unable to be adequately consolidated by rodding. Once casting was complete, the rings were immediately transferred to the curing/testing room. The testing/curing room was kept at  $73^{\circ}\text{F} \pm 3^{\circ}\text{F}$ . The top surface was wet cured using saturated burlap and plastic for  $24 \pm 1$  hour after casting, as shown in Figure 4-16.

TML 120 ohm resistance strain gauges with a gauge length of 10 mm were used to monitor strain in the interior steel rings. Four strain gauges were bonded to the interior surface of

each steel ring. They were placed equidistantly around the circumference and at mid-height of the ring. A view of a bonded strain gauge can be seen in Figure 4-15.

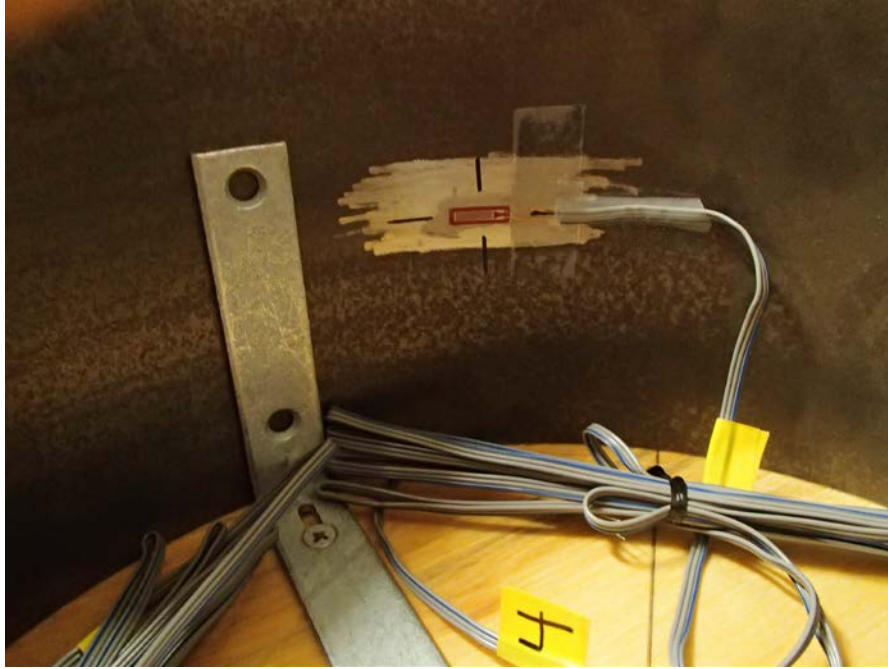

Figure 4-15: Bonded Strain Gauge to Steel Ring for Shrinkage Test



Figure 4-16: Wet Curing of the Top Surface of the Shrinkage Rings using Prewitted Burlap and Plastic Covering

After  $24 \pm 1$  hours of curing, the bead of silicone caulking was cut away, the screws on the outer corner braces were released, the corner braces were slid away from the Sonotube and the Sonotube ring was removed. The Sonotube rings were removed from the concrete using a Gilson screw-driver style cylinder mold stripping tool. After the outer corner braces and Sonotube ring were removed, the top surface of the concrete ring was sealed. The top surface was sealed by running a bead of construction adhesive on the inside and outside edge of the concrete ring and then pressing a donut shaped rubber mat into the adhesive. The rubber mat used for sealing was a 1/16-inch-thick PVC shower pan liner cut to shape. Once this process was complete, the inner, the top and the bottom edges of the concrete ring were sealed by the steel tube, the plastic PVC liner, and the urethaned plywood sheet, respectively, leaving the outer surface of the concrete ring as the only exposed surface.

To allow the steel ring to contract as concrete was shrinking against it, the screws were loosened on the interior corner braces and the central tie down system was released by sliding the corner braces toward the center of the test setup. The strain gauges were then connected to a Micro Measurements P3 Strain Indicator and Recorder, Version 2.11 using a quarter bridge wiring schematic, as shown in **Error! Reference source not found.** Using this device, the strain values were manually recorded daily. The temperature and relative humidity were also documented daily. While the test was running, the concrete ring was inspected daily for any signs of cracking. Conclusions from the daily visual inspection were documented as needed.



Figure 4-17: Micro Measurements P3 Strain Indicator and Recorder, Version 2.11 Used to Record Strains During the Shrinkage Test

#### 4.5.1.3 Alkali Silica Reactivity

To test the potential of a deleterious alkali-silica reaction occurring with the combination of ASTM Type III Cement and/or Class F fly ash and Source 2 aggregates (aggregates from Source 1 had already been discarded from the testing program at this point), *ASTM Standard C1567: Standard Test Method for Determining the Potential Alkali-Silica Reactivity of Combinations of Cementitious Materials and Aggregate (Accelerated Mortar-Bar Method)* was used. This ASTM standard is very similar to ASTM C1260. The only difference is that the use of fly ash is permitted in ASTM C1567 and it is not in ASTM C1260. Since fly ash is used as a partial replacement of cement in each of the selected concrete mixtures, ASTM C1567 was chosen to be used.

Since Source 2 aggregates were used for all trial batch concrete mixtures reported in this research project, they were the aggregates tested for a potential deleterious alkali-silica reaction. As discussed in Section 3.2.1, Source 2 fine aggregates were sourced from river stone and Source 2 coarse aggregates were obtained from crushed basalt stone, which are mined from the supplier's quarry. Consequently, Source 2 fine aggregates and Source 2 coarse aggregates are comprised of different chemical compositions and the potential for a deleterious alkali-silica reaction occurring in combination with cement and/or fly ash was analyzed separately for each aggregate size.

As shown in Figure 4-18, ASTM Standard C1567 provides a table which specifies a required gradation for the aggregates used in the ASR test. As seen in Figure 4-18, the largest particle size specified is 4.75 mm (No.4 sieve), which means the required gradation does not contain particles sizes seen in coarse aggregate gradation curves. In order to test the Source 2 coarse aggregate, a crushed version of the coarse aggregate had to be obtained. Crushed stone from the same quarry as the coarse aggregate was obtained from the supplier and used for this test to comply with aggregate size requirement. Crushed stone is comprised of fine particles created during the crushing process of the basalt stone used as coarse aggregate for the project.

Figure 4-19 shows the gradation curve of both the crushed stone and Source 2 fine aggregates compared to the required aggregates gradation to be used for the ASR test. To attain the required gradation, Source 2 fine aggregates and stone dust were sieved to separate their particle sizes. Then quantities of each particle size were proportioned to create the required gradation curve, specified by the ASTM C1567.

Sieve Size		Mass, %
Passing	Retained on	
4.75 mm (No. 4)	2.36 mm (No. 8)	10
2.36 mm (No. 8)	1.18 mm (No. 16)	25
1.18 mm (No. 16)	600 $\mu$ m (No. 30)	25
600 $\mu$ m (No. 30)	300 $\mu$ m (No. 50)	25
300 $\mu$ m (No. 50)	150 $\mu$ m (No. 100)	15

Figure 4-18: Required Gradation of Aggregates Used in Alkali-Silica Reactivity Testing as Specified by ASTM C1567

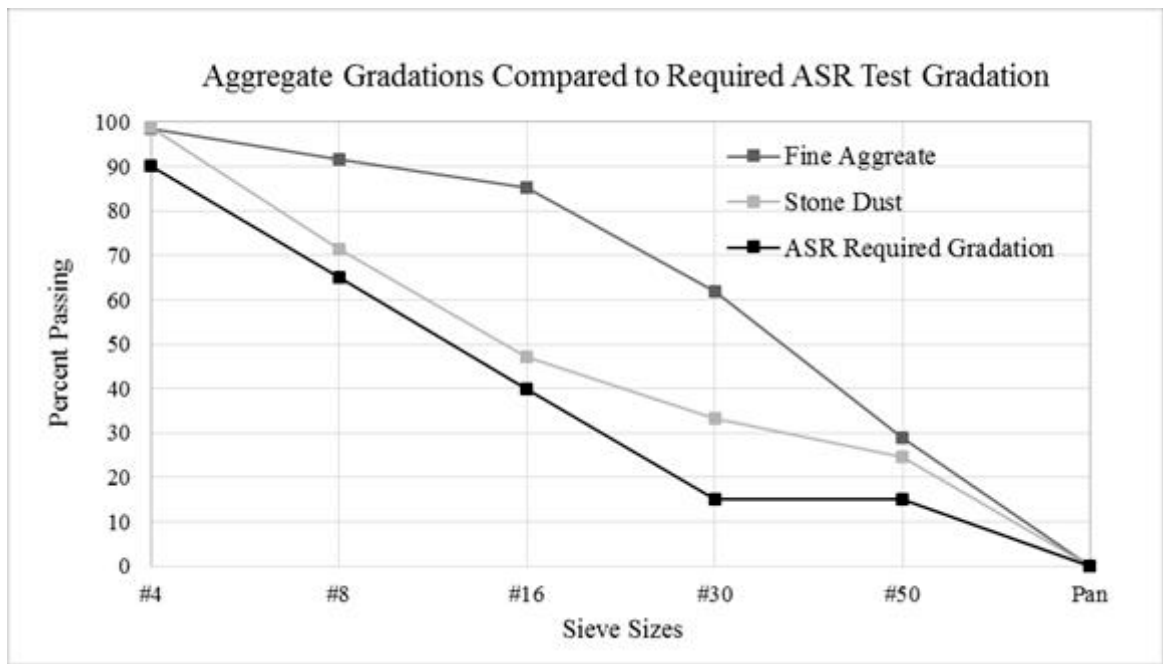

Figure 4-19: Gradation of Source 2 Fine Aggregate and Stone Dust Compared to Required Aggregate Gradation for Use in ASR Test

The mixture design used to create specimens for the ASR tests can be seen in Table 4-2. These were developed based on the guidelines provided in ASTM C1567. The guidelines specify dry materials to be proportioned as 1 part cementitious material to 2.25 parts graded aggregate by mass for aggregates with a relative density (oven-dried) at or above 2.45. This was the case for both the Source 2 fine aggregates and the stone dust. A w/cm ratio of 0.47 was also specified. A fly ash replacement percentage was not specified in the ASTM standard; therefore, a 15% replacement was used, since it was the percentage used for the two selected concrete mixtures as

discussed in Section 3. ASTM 1567 does not specify the use of HRWR for a mix design containing cement and fly ash as the only cementitious materials. HRWR is specified as an option only if the mixture contains silica fume or metakaolin. Therefore, HRWR was not added to the mix design used for ASR testing.

Table 4-2: Mortar Batch Mix Designs Used for ASR Testing

Constituents		Testing Coarse Aggregate Reaction	Testing Fine Aggregate Reaction	Units / 3 ft <sup>3</sup>
Aggregate	Modified Stone Dust	18.00	-	lb
	Modified Source 2 Fine Aggregate	-	18.00	lb
Cement	ASTM Type III	6.80	6.80	lb
Mitigation	Class F Fly Ash	1.20	1.20	lb
Water		3.98	3.98	lb

The batches mixed for this test are considered a mortar, rather than concrete, because the largest aggregate size used in the mixture can pass through a No.4 sieve. Therefore, ASTM Standard C305 was used as the mixing procedure for the mortar. This standard was used to determine the order of constituents to be added, but a small machine mixer, as specified in the standard, was not available, so the mortar was mixed by hand.

The cement and fly ash were mixed together first and then added to the water. Once the paste was formed, the modified version of either the source 2 fine aggregate or stone dust was added slowly to the paste. A picture showing this step of mixing can be seen in Figure 4-20. The volume of mortar mixed in each batch was equal to three cubic feet; this was a volume large enough to fill three specimens. The mortar was cast into the molds using two equal layers, rodding each layer. The specimens were finished to a smooth surface, as shown in Figure 4-21, using a trowel.



Figure 4-20: Hand Mixing the Mortar for ASR Testing



Figure 4-21: Mortar Cast into Molds for ASR Testing



The molds used to form the specimens were as specified in ASTM C490. Single molds were used with a cross-sectional dimension equal to 3.5 inches and a length equal to 11.25 inches. Six specimens, two batches with three specimens each, were cast for each aggregate type, source 2 fine aggregate and stone dust. Therefore, there were twelve specimens in total.

Each specimen was cured at 80°F and 100% moisture for 24 hours. Then as specified, were removed from their molds and submerged in water for 24 hours and kept in an oven set to 176°F. Distilled water was used to ensure that the water composition would not affect a potential alkali-silica reaction. Next, each specimen was submerged in a sodium hydroxide solution, which was created as specified in ASTM C1567. The sodium hydroxide solution contained 40.0 grams of NaOH per 1.0 L of distilled water. The specimens were each kept in the sodium hydroxide solution for 14 days, also in an oven kept at 176°F. Specimens containing different aggregates were kept in separate containers at all steps of the procedure as to avoid cross-contamination.

High density polyethylene containers with lids, such as the one shown in Figure 4-22, were used to submerge the specimens in water and sodium hydroxide. The containers used for this purpose were required to be in contact with sodium hydroxide for a 14-day period; sodium hydroxide corrodes metal and glass; therefore, the containers could not be made of these materials. The containers also had to be able to withstand the 176 °F temperature requirement. Most plastics have a melting point that is under 176 °F, but high density polyethylene (HDPE) containers were able to be used in this application since the melting point of HDPE is in the range of 250 to 350 °F.



Figure 4-22: ASR Specimens Submerged in Sodium Hydroxide Solution

As specified in ASTM C1567, the length of each specimen was recorded daily and around the same time each day. The initial reading for each specimen was taken when it was first removed from the mold, after 24 hours of curing. Before each reading was taken, the specimens were laid out, as shown in Figure 4-23, and gauge studs, which were cast into each specimen during casting, were cleaned to avoid any build up, which could affect the length reading. A Humboldt, Model H3250, length comparator was used to take the length readings, as shown in Figure 4-24. To use the length comparator, a 10-inch steel reference bar was first inserted into the comparator and the dial gauge was reset to zero. Then the specimen was placed in the length comparator using the embedded gauge studs, as shown in Figure 4-24. The length of each specimen was measured daily, for 12 days, using this procedure. Once this test was completed, the length readings were used to determine if a deleterious alkali-silica reaction occurred within each specimen. The results from this test can be seen in Section 5.



Figure 4-23: ASR Specimens Drying on Rags before Taking Length Change Measurements



Figure 4-24: Length Comparator Shown Being Zeroed on Left and Taking a Reading of an ASR Specimen on Right

#### ***4.5.1.4 Freeze-thaw Testing***

The freeze-thaw tests were conducted following ASTM C666 with assistance from MassDOT at their laboratory facilities located in Newton, MA. Four prisms satisfying requirements of ASTM C490 were fabricated in two sets with the same mix used to fabricate the closure pours for the

large-scale specimens presented in Chapter 6. Companion cylinders were also cast at the same time to determine strength at initiation of freeze-thaw cycling. Figure 4-25 shows the freeze-thaw prisms after casting. After 24 hrs, the prisms were demolded and placed in a curing box at 100% humidity and a temperature of 70°F for a period of approximately 14 weeks prior to shipping to the MassDOT laboratory. The prisms were subjected to 300 freeze-thaw cycles with temperatures between 0°F and 40°F (-18°C and 4°C). After every 36 cycles, the following properties were measured: fundamental resonant transverse frequency (ASTM C215), length change (ASTM C490), and mass change. Results are presented in Chapter 5.



Figure 4-25: Prisms used for Freeze-Thaw Testing

#### **4.5.1.5 Bar Pullout Test**

The bar pullout test used to compare the bond strength between concrete and reinforcing bars followed ASTM Standard A994: *Standard Test Method for Comparing Bond Strength of Steel Reinforcing Bars to Concrete Using Beam-End Specimens*. For this test, No. 4 and No.6 grade 60, epoxy coated bars were tested. The bonded length used for each bar was equivalent to a percentage of the development length. The development length for each test bar (No.4 epoxy

coated and No.6 epoxy coated) was found using equation 12-1 in ACI 318-11, Equation 4-1. More specifically, the simplified version, specified in ACI 318-11, with clear spacing and cover are as specified was used. All factors were taken to be one, other than  $\psi_e$ , which was taken to 1.5 due to the epoxy coated of the test bars. The test bars were grade 60, so nominal  $f_y$  was set equal to 60,000 psi. The value used for  $f'_c$  was equal to 4,000 psi, which was about the strength expected at the time of testing. Using these factors and the steel and concrete strength, the development length was calculated for each size. The development length was found to be 19.0 inches for the No.4 test bar and 28.5 inches for the No. 6 bar. Since the full development length of the No. 6 would not fit within the dimensions of the concrete specimen which were defined by the standard specification, a percentage of the total development length had to be used for the bonded length. Furthermore, since the bar pullout test is a comparative test, the same percentage of the development length had to be used for the No. 4 test bar. This was done so that results from each bar size test could be compared directly. The portion of each development length used as the bonded length was 63%; this made the bonded length of the No. 6 bar 18 inches and the bonded length of the No. 4 bar 12 inches for use in the bar pullout tests conducted in this research, as shown in

$$l_d = \left( \frac{3}{40} \frac{f_y}{\sqrt{f'_c}} \frac{Y_1 Y_2 Y_3 \lambda}{\left( \frac{c_b + K_{tr}}{d_b} \right)} \right) d_b \cdot \left( \frac{c_b + K_{tr}}{d_b} \right) = 1.5$$

Equation 4-1: Simplified ACI 318 Development Length Equation

The dimensions of the bar pullout concrete specimens were as specified in ASTM A944. For the No. 6 test bar, the dimensions of the concrete specimen were as follows: 14 inches wide, 14 inches high and 24 inches long, as shown in Figure 4-27. For the No.4 test bar, the concrete specimens were also 14 inches high and 24 inches long, but were 12 inches wide, Figure 4-26. The reinforcement schematics are also provided in Figure 4-26 and Figure 4-27. As shown in the schematics, two longitudinal bars, other than the test bar were used in each concrete test

specimen. The longitudinal bar size was determined using ASTM A944. For a No. 6 test bar, No. 5 longitudinal reinforcement was used. For a No. 4 test bar, No. 3 longitudinal reinforcement was used. Each concrete test specimen also had four stirrups made with No.3 reinforcement. Each stirrup hoop was 6 inches wide and 9.5 inches tall. The stirrups and longitudinal bars were used to reinforce the specimen and ensure no concrete cracking would occur while transporting the specimen and during handling to set the specimen in the test rig. There were also reinforcing bars used to connect the tops of the stirrups, which helped keep them in place during casting. Since these reinforcing bars did not serve a structural purpose, the diameter was not important and No. 5 bars were selected for these bars. For lifting purposes, 6-inch straight coil loop inserts were cast into each specimen and were used with coil bolts to lift and move the specimens once they were removed from the formwork. The reinforcement for a No. 4 test bar tied within formwork can be seen in Figure 4-28.

The bonded lengths of the test bars were controlled by using polyvinyl chloride (PVC) pipes as bond breakers between the bar and the concrete cast around the bar. As seen in Figure 4-26 and in Figure 4-27, there is a small bond breaker used at the end of specimen where the test bar is being pulled out. This is used to prevent a cone-type pullout failure. At the other end of the specimen, the longer PVC bond breaker extends out of the specimen, as shown in Figure 4-26 and

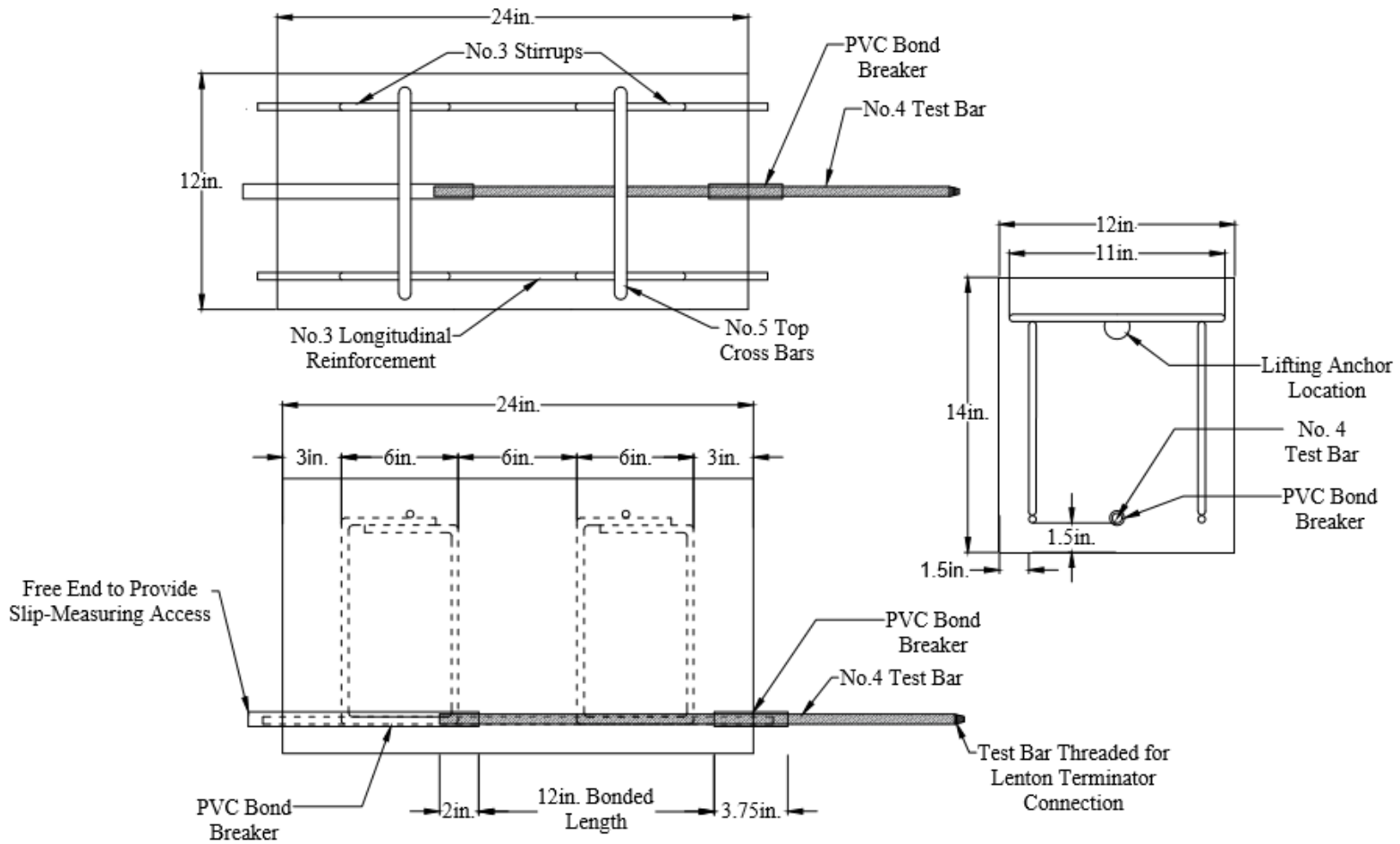

Figure 4-26: Schematic of Bar Pullout Test Reinforcement for No.4 Test Bar

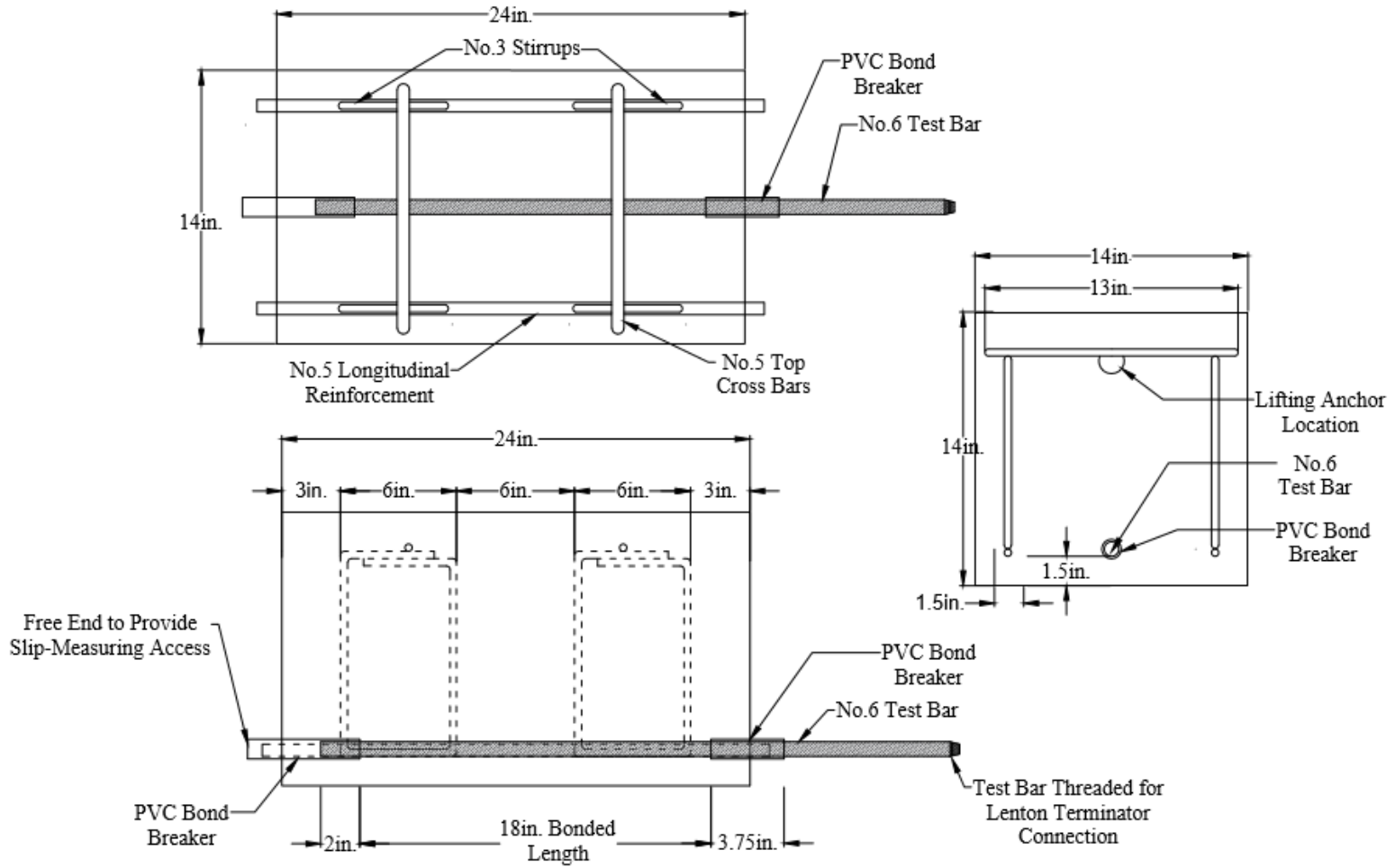

Figure 4-27: Schematic of Bar Pullout Test Reinforcement for No.6 Test Bar



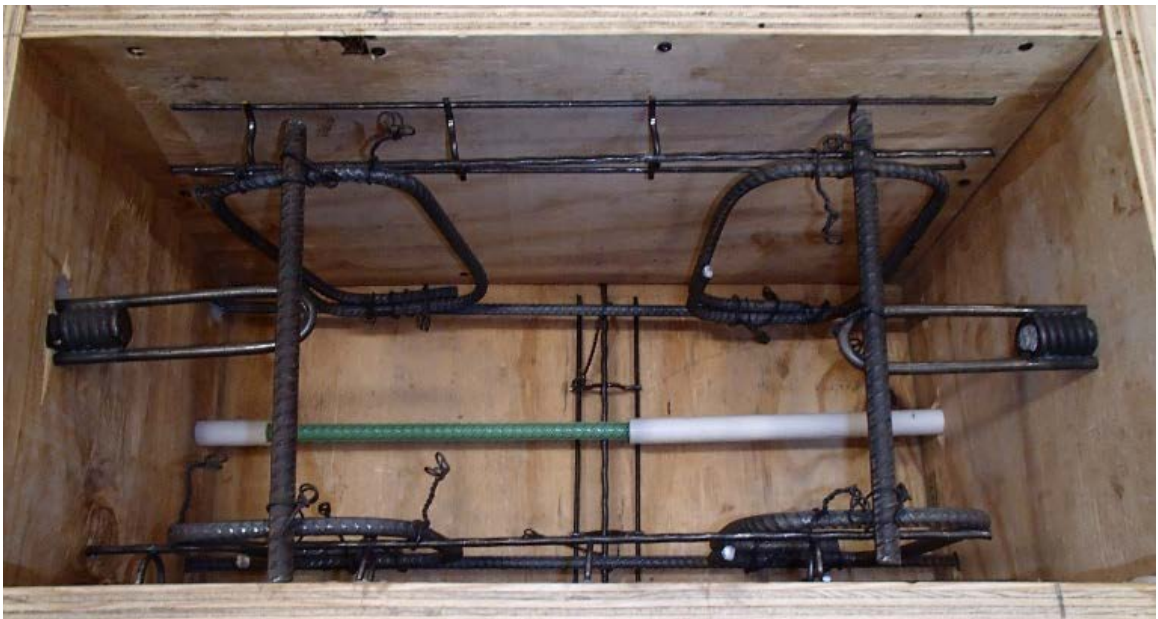

Figure 4-28: Formwork and Steel Reinforcement Schematic for Bar Pullout Test Specimens Using a No. 4 Test Bar

Figure 4-27. This is to allow access to the free end of the test bar for slip measurement during the test. Between the two bond breakers, a distance equal to 18 inches for the No. 6 test bar and 12 inches for the No. 4 bar is left exposed, equaling the bond length determined as described

previously. The PVC bond breakers for a No. 4 test bar can also be seen in Figure 4-28. The apparatus used to measure slip can be seen in Figure 4-29. Hidden within the specimen, a 1/2-inch nut was attached to the free end of the test bar. It was attached by bonding it with an 8-minute epoxy. A piece of 1/2-inch threaded rod was screwed into the bonded nut. As seen in Figure 4-29, a washer and electric tape was used to keep the rod steady and centered within the PVC during the test. Angle braces were attached to the rod to allow attachment to a Celesco cable-extension position transducer, Model MTA, with a 3-in. length capacity. The base of the position transducer was attached to the concrete specimen through a bonded angle brace. This was also bonded using an 8-minute epoxy and served as reference to measure relative movement between the bonded bar and the concrete specimen. The wire of the linear potentiometer was fully extended at the start of each test, and as slip occurred, the wire would contract, providing a bar slip reading.

The test setup implemented for the bar pullout test was based on the schematic provided in ASTM A944. A schematic of the test apparatus used for this research project can be seen from a top view in Figure 4-30 and a side view in Figure 4-31. An image of the test apparatus is also provided in Figure 4-32. As seen in these figures, the concrete specimen is set on top of a W12x26 section. Steel plates were stacked between the test specimen and the W12x26 section to adjust the height of the specimen as needed. The specimen was brought to bear against an L3x3x3/8 angle, which was used to keep the specimen in place when the test bar was being pulled horizontally.



Figure 4-29: Apparatus Used for Measuring Slip During Bar Pullout Test

The test bar was pulled through the use two SPX Power Team 30 ton rams, model No. RH306. On each side of the test setup, a one inch diameter, high strength threaded rod was passed through the ram, a load cell, a bracing bracket and perpendicularly through an HSS 5 in. by 5 in. by 3/6 in. section (HSS5x5x3/16). The perpendicular HSS5x5x3/16 section was not attached to the sections below, and, therefore was free to move. The bracing brackets on each side were secured to the HSS5x5x3/16 section below it using an ASTM A490 bolt. The bearing brackets were fabricated using two 1" thick x 5" x 5" plates. The two plates were welded together as shown in Figure 4-31. Two 0.5" thick stiffeners were added to bracket, one to each side, as seen in Figure 4-30 and Figure 4-31.

As load was applied to the system, and the ram extended, the bearing bracket provided a reaction to keep the ram in place, forcing the perpendicular HSS5x5x3/16 section to be pulled towards the rams and away from the specimen. The test bar passed through holes drilled through

the free-moving HSS5x5x3/16 section, which served as a yoke, in a direction perpendicular to the bar coming from the specimen. The test bar was attached to the HSS5x5x3/16 section using a Lenton terminator threaded to the end of the bar extending from the specimen, as shown in Figure 4-30. As the rams simultaneously pulled the HSS5x5x3/16 yoke away from the specimen, it also pulled the test bar. The system was loaded until the concrete-reinforcement bond, concrete block or steel reinforcement failed.

The selected concrete mixtures, MIX 6-HD and MIX 15-HD, as described in Section 3 were the concrete mixtures evaluated in this test. To cast each concrete test specimen, the concrete mixture was mixed in the laboratory as typically done throughout this project, and as described in Section 4.2. For each concrete specimen cast, at least three companion cylinders were also cast. These companion cylinders were used to confirm the compressive strength of the concrete specimen at time of testing. When casting concrete specimens for a No. 4 test bar, enough volume could be mixed in each batch to fill one specimen and three companion cylinders. The volume of a No. 6 test bar specimen is slightly greater than that of a No. 4 test bar specimen, and exceeded the capacity of the concrete mixer. Therefore, two batches of concrete were used for each No. 6 test specimen, with each batch filling half of the specimen and two companion cylinders. Two companion cylinders came from each batch, rather than three companion cylinders coming from one batch to confirm that the variability between the two batches of concrete used for each No. 6 bar specimen was not significant.

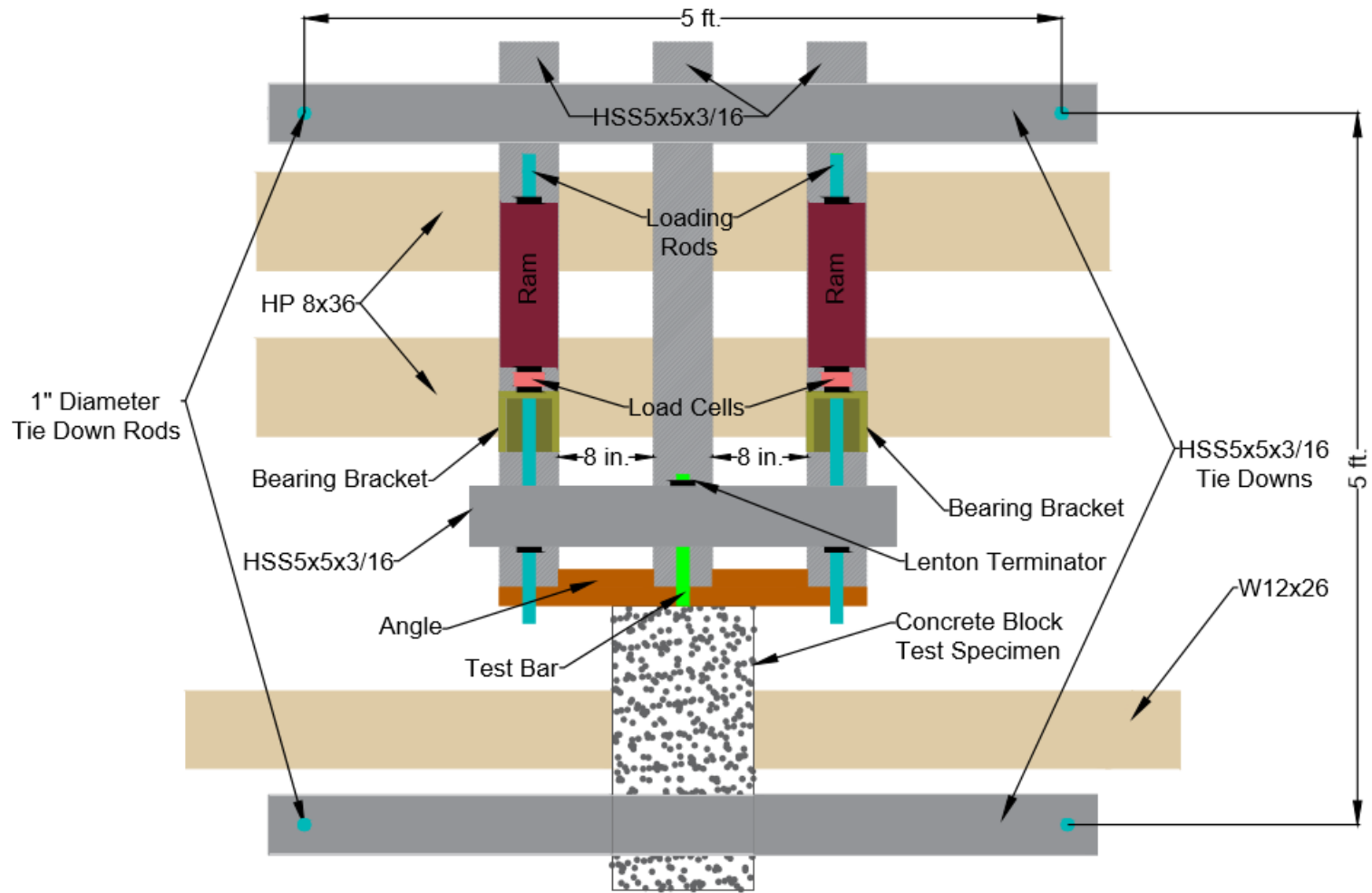

Figure 4-30: Top View of Test Apparatus Schematic

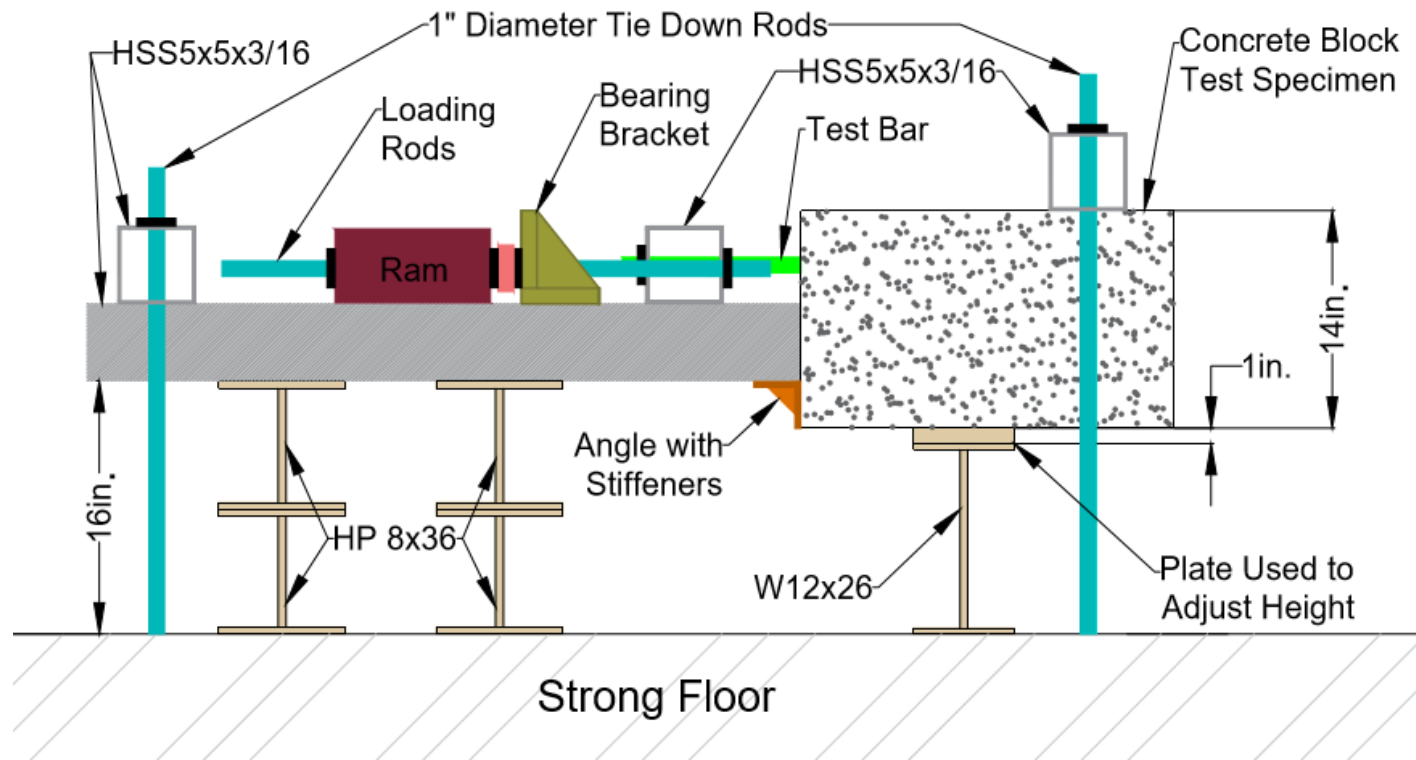

Figure 4-31: Side View of Test Apparatus Schematic



Figure 4-32: Bar Pullout Test Apparatus

Each specimen for the No. 4 and No. 6 bars was cast in two equal layers. Each layer was consolidated using an internal vibrator. The top of each specimen was finished using a trowel. Once the concrete in a specimen reached initial set, the specimens were covered with a layer of wet burlap and plastic. The specimens were left to cure for 12 hours at in situ conditions within the laboratory, where the temperature was approximately 75°F and the relative humidity was approximately 30%. Results from each of these tests can be found in Section 5.3.1, including the failure type, failure load and any bar slip that occurred during the test.



## 5 RESULTS OF CONCRETE MIXTURE TESTING

### 5.1 Strength

#### 5.1.1 Compressive Strength

The compressive strength was measured for every batch of every concrete mixture prepared during this project. A table providing the compressive strengths measured for each batch can be found in Appendix B. As stated in Section 1.3: Scope of Work, the compressive strength goal for the concrete mixtures developed in this project was to reach 4000 psi in 12 hours. When developing the concrete mixtures, the compressive strength was a major factor used in determining two concrete mixtures that would be selected for further testing. This development process was explained in detail in Section 3.

Strength gain curves of trial batch concrete mixtures are shown in Figure 5-1. Each line in the plot represents a different concrete mixture with compressive strength values plotted at 12 and 24 hours as well as 7 and 28 days. This plot is presented only to provide an idea of the general trends in the compressive strength data, not to provide compressive strength values of specific trial batch concrete mixture. The compressive strength that trial batch concrete mixtures reached in 12 hours ranged from 1000 to 5900 psi. The compressive strength increased an average of 2000 psi in the following 12 hours, reaching between 3800 and 7600 psi at 24 hours of curing. The compressive strength after 7 days of curing was between 6500 and 9400 psi, yielding an overall average 7-day compressive strength equal to 8000 psi. The compressive strength at 28 days of curing ranged from 7500 to 12000 psi, yielding an overall average 28-day compressive strength equal to 10,000 psi. These ranges result in compressive strengths of approximately 36,

55 and 80% of the 28-day compressive strength reached at 12 hours, 24 hours and 7 days, respectively.

The effect of fly ash replacement level on strength gain rates was also evaluated in Figure 5-1. Darker lines correspond to higher amounts of fly ash used in each concrete mixture. The lightest lines have 0% fly ash replacement. The darkest lines have 25% fly ash replacement, which is the highest replacement percentage used in this project. In general, the concrete mixtures with a higher fly ash replacement had strengths that developed later than those with a lower fly ash replacement. However, there were outliers in this trend, such as the concrete mixture which achieved the lowest 28-day compressive strength, as shown in Figure 5-1 as a dark line. The concrete mixture contained 25% fly ash but had very little strength gain between 7 and 28 days, only 2000 psi.

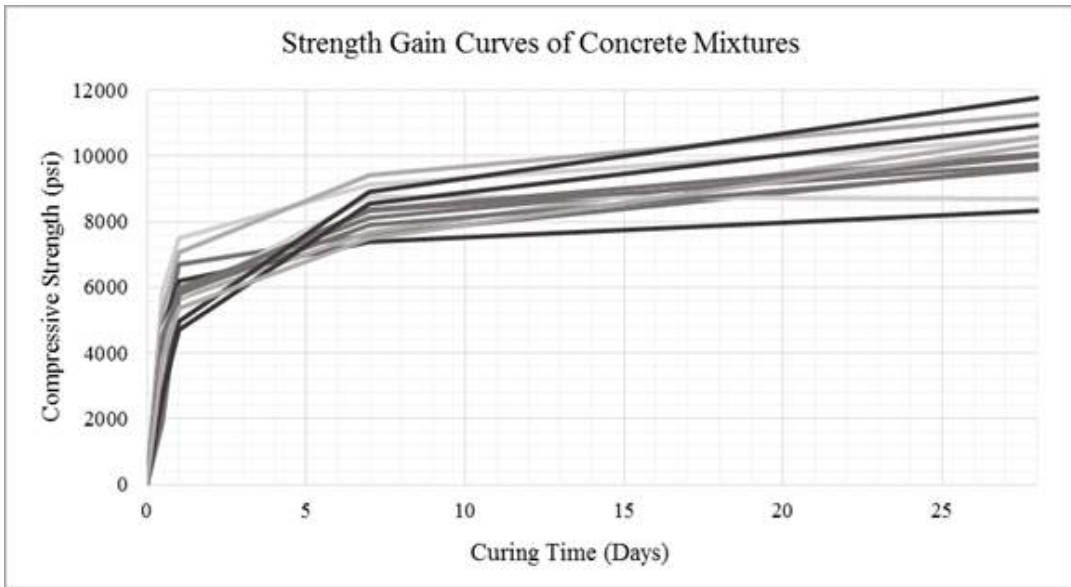

Figure 5-1: Strength Gain Curves of Trial Batch and Selected Concrete Mixtures (Light to Dark)

The effect of w/cm on the 12-hour compressive strength of concrete mixtures was also evaluated, as shown in Table 5-1. The average 12-hour compressive strength of concrete mixtures with a w/cm ratio equal to 0.26 was 5030 psi. The average 12-hour compressive strength dropped by about 40% to 3550 psi when the w/cm ratio was increased to 0.29. However, with a subsequent increase in w/cm ratio of the same amount to 0.32, the 12-hour compressive strength only decreased by approximately 10%.

Table 5-1: Comparison of Average Compressive Strength Values with Varying w/cm Ratios

w/cm ratio	12-HOUR Compressive Strength (psi)
0.26	5030
0.29	3550
0.32	3200

An assessment was also performed on the effect of the  $V_{\text{paste}}/V_{\text{voids}}$  ratio used in a concrete mixture. The concrete mixtures used to compare  $V_{\text{paste}}/V_{\text{voids}}$  had other proportions that were equal. The w/cm ratio was equal to 0.29, 1/2" coarse aggregate was used and each concrete mixture contained 15% fly ash replacement. As seen in Table 5-2, the 12-hour compressive strengths were not significantly affected by a change in the  $V_{\text{paste}}/V_{\text{voids}}$  ratio. The largest difference in strength was 2%.

The effect of coarse aggregate size on compressive strength was also assessed. In order to compare only the coarse aggregate size, the other parameters were kept constant. The w/cm ratio was equal to 0.29, the  $V_{\text{paste}}/V_{\text{voids}}$  ratio was equal to 1.75 and the average was taken from trial

batches contained 15 and 20% fly ash replacement. As shown in Table 5-3, the 12-hour strength was significantly affected by a change in coarse aggregate size. Trial batches with 3/8" coarse aggregate had a 12-hour compressive strength 2.5 times greater than those with 1/2" coarse aggregate. However, the constructability of trial batches containing 3/8" coarse aggregate was unacceptable.

Table 5-2: Comparison of Average Compressive Strength Values with Varying  $V_{\text{paste}}/V_{\text{voids}}$  Ratios

$V_{\text{paste}}/V_{\text{voids}}^1$	12-HOUR Compressive Strength (psi)
1.75	3880
1.50	3810
1.25	3880
1 - Averaged from concrete mixtures with w/cm = 0.29, 15% fly ash replacement and 1/2" coarse aggregate	

Compressive strength values of the two selected concrete mixtures, MIX 6-HD and MIX 15-HD, at 12 and 24 hours after curing are shown in Figure 5-2. These strength values are also reported in Table 5-4, along with 7- and 28-day compressive strengths of the two selected concrete mixtures. As seen in Figure 5-2, the average compressive strength reached in 12 hours was slightly below 4000 psi for both MIX 6-HD and MIX 15-HD. MIX 6-HD reached an average compressive strength of 4000 psi in approximately 13.1 hours and MIX 15-HD reached an average compressive strength of 4000 psi in approximately 13.4 hours, which was obtained by linear interpolation between the 12 and 24 hour strengths. If this strength gain is inadequate for the application desired, there are options for increasing strength gain of the concrete mixtures.

Table 5-3: Comparison of Average Compressive Strength Values with Varying Coarse Aggregate Size

Coarse Aggregate Size (inches)*	12-HOUR Compressive Strength (psi)
1/2	1560
3/8	3770

\*Averaged from concrete mixtures with w/cm = 0.29, 15 & 20% fly ash replacement and  $V_{paste}/V_{voids} = 1.75$

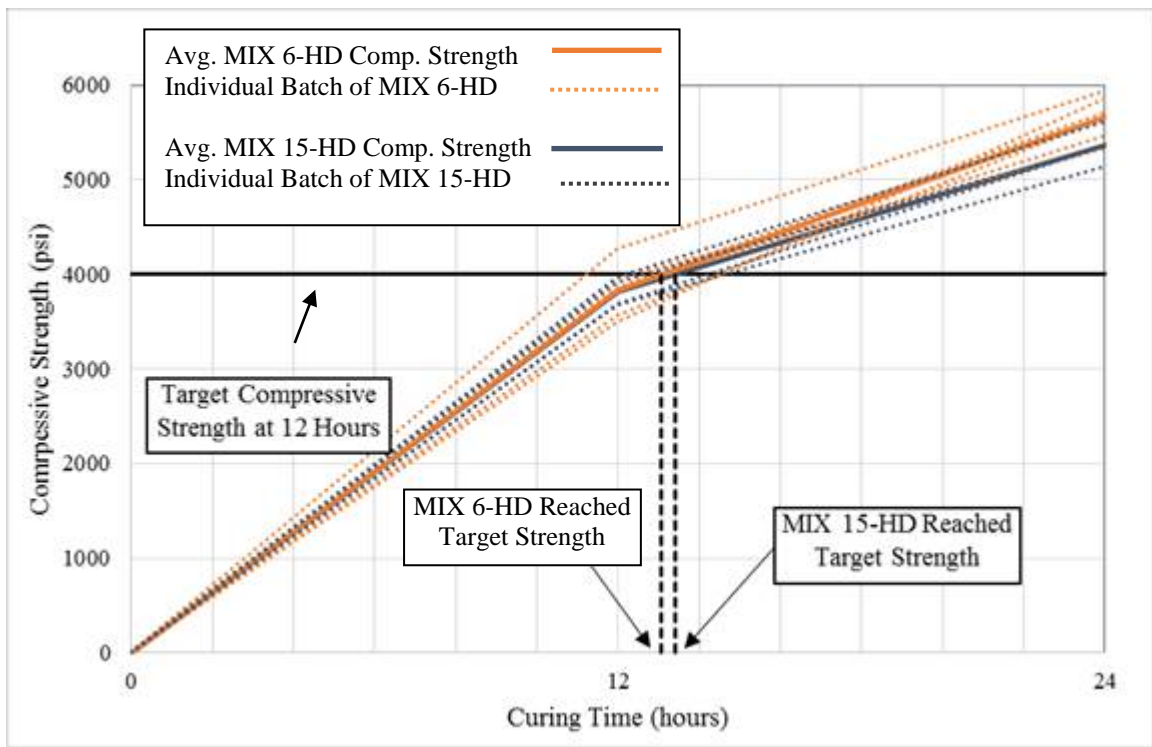

Figure 5-2: Compressive Strength Curves of Selected Concrete Mixtures

As noted in Section 4, compressive strength specimens in this project were cured at 80°F and 100% relative humidity. The option of curing compressive strength specimens at a higher temperature was explored as an option of increasing compressive strength in a short time period.

MIX 6-HD and MIX 15-HD were cured at 110°F and 100% relative humidity, creating trial batches MIX 6-HD-H and 15-HD-H, respectively. The results of this experiment are provided in Table 5-4. By increasing the curing temperature to 110°F, the target compressive strength of 4000 psi was reached in approximately 9 hours for both selected concrete mixtures. The compressive strength reached in 12 hours was 5140 and 5200 psi for MIX 6-HD-H and 15-HD-H, respectively.

Table 5-4: Compressive Strength Values for Selected Concrete Mixtures

Concrete Mixture	Batch	Compressive Strength (psi)			
		12-HOUR	24-HOUR	7-DAY	28-DAY
MIX 6-HD	a	4280	5940	-	-
	b	3500	5870	-	-
	c	3870	5710	7680	10560
	d	3570	5660	-	-
	e	3970	5340	-	-
	f	3840	5470	-	-
	<b>Average</b>	<b>3840</b>	<b>5660</b>	<b>7680</b>	<b>10560</b>
MIX 6-HD-H	a	5140	6160	-	-
	<b>Average</b>	<b>5140</b>	<b>6160</b>	-	-
MIX 15-HD	a	3970	5620	-	-
	b	3700	5360	-	-
	c	3930	5350	7500	10300
	d	3670	5140	-	-
	<b>Average</b>	<b>3820</b>	<b>5370</b>	<b>7500</b>	<b>10300</b>
MIX 15-HD-H	a	5200	6160	-	-
	<b>Average</b>	<b>5200</b>	<b>6160</b>	-	-

The compressive strength that the two selected concrete mixtures, MIX 6-HD and MIX 15-HD reached in 12 hours is only about 5% under the target strength. If it is necessary to reach the exact target compressive strength of 4000 psi in 12 hours, the curing temperature can be increased. By increasing the curing temperature, a 12-hour compressive strength 30% greater than the target was attained during this project.

## **5.2 Constructability**

### **5.2.1 Slump/Spread**

A slump or spread measurement was taken for every concrete mixture that was prepared for this project. In Appendix C, a full tabulated list of slump and spread measurements taken for each concrete mixture is provided. Great variability existed in the consistency of trial batch and selected concrete mixtures, not only between different concrete mixture designs, but also within one concrete mixture design. This can be clearly seen with the two selected concrete mixtures, MIX 6-HD and MIX 15-HD, as shown in Table 5-5. For MIX 6-HD, the consistency ranged from a slump value of 3 inches to a flowable mixture that had a spread value of 21 inches. An example of MIX 6-HD with a flowable consistency can be seen in Figure 5-4 and an example of MIX 6-HD with a thick consistency can be seen in Figure 5-3. Similarly, MIX 15-HD ranged in consistency from a mixture with a slump of 4 inches to a mixture with a spread of 30 inches. Photos demonstrating thick and stiff versus flowable consistencies of MIX 15-HD are shown in Figure 5-5 and Figure 5-6, respectively.



Figure 5-3: Example of MIX 6-HD with Stiff Consistency



Figure 5-4: Example of MIX 6-HD with Flowable Consistency



Table 5-5: Slump and Spread Values for Selected Concrete Mixtures

Concrete Mixture	Test Executed	Slump or Spread Reading (inches)
6-HD	spread	21
		19
		18
		17
	slump	8
		5
3		
15-HD	spread	30
		21
		18
		16
		16
	slump	4

It is unclear the exact causes of variability in the consistency, and, therefore the slump and spread readings. As discussed in Section 3, there were measures taken to reduce variability in concrete mixtures, such as soaking the concrete mixer the night before mixing, letting the aggregates fully cool to room temperature before use and maintaining the same mixing water temperature. The temperature of the concrete mixture was taken immediately after mixing. At this point, no heat had been generated due to the reaction that occurs with hydration of cementitious materials. The temperature reading was taken solely to ensure that the temperature of all components added to the mixture were consistent between batches. The temperature and relative

humidity of the lab where the concrete was mixed was also measured every time a batch was mixed. The temperature and relative humidity recordings for the two selected concrete mixtures are plotted with corresponding spread or slump reading in Figure 5-7. Overall, there was no trend observed between temperature and relative humidity with the consistency of concrete mixtures. For MIX 6-HD concrete mixture batches, it can be seen that with higher relative humidity, there was a significant increase in flowability of the concrete. However, this was not the case for MIX 15-HD concrete mixture batches. There was no correlation observed between temperature and slump and/or spread measurements of the selected concrete mixtures.



Figure 5-5: Example of MIX 15-HD with Stiff Consistency



Figure 5-6: Example of MIX 15-HD with Flowable Consistency

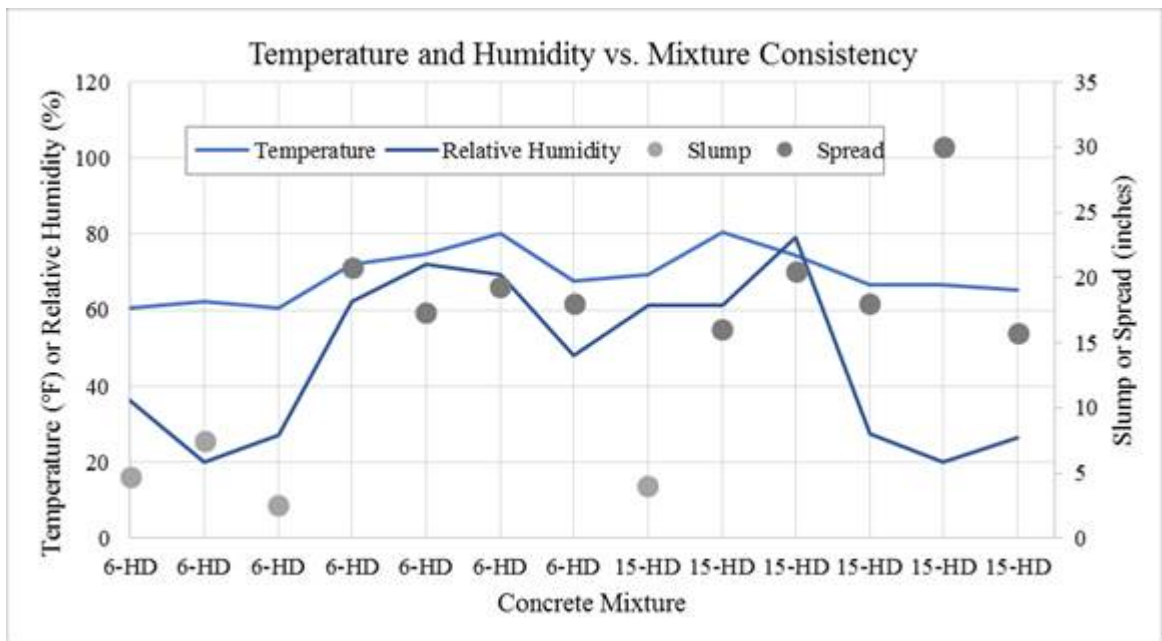

Figure 5-7: Temperature and Relative Humidity Recordings at Time of Mixing Versus Spread and Slump Readings of the Selected Concrete Mixtures

There was also variability in the consistency of other concrete mixtures. Figure 5-8 provides the slump and spread values of all concrete mixtures throughout this project. A tabulated

version of the data is provided in Appendix B. The mixtures that have a slump reading reported as 12 inches were those with highly flowable consistencies preventing a slump reading to be taken. These concrete mixtures should have had a spread test performed in place of the slump test, but at the time of mixing the research team was not prepared to conduct the spread test.

Through this plot, the variability in slump and/or spread reading was also observed in MIX 14. MIX 14 was batched eight times to examine variability in its consistency. The consistency of MIX 14 ranged from a slump of 0 inches to a spread of 31 inches. This range in consistency is even greater than the range seen in the two selected concrete mixtures (MIX 6-HD and MIX 15-HD).

Since the batches mixed for this project were of small volume, it is possible that a very small, undetectable change in the mixing process or quantities of constituents could cause significant variability in the concrete mixtures. This plot also demonstrates the increase in flowability of the two selected concrete mixtures when the HRWR dosage was increased. In general, MIX 6 and MIX 15 had more batches with low slump readings than MIX 6-HD and MIX 15-HD.

It was found that, apart from the HRWR dosage, the w/cm ratio and the coarse aggregate sizes had the greatest effect on consistency of the concrete mixtures. As seen in Figure 5-8, MIX 1 - MIX 4, had in general low slump values. These are the mixtures with w/cm ratios equal to 0.26. MIX 2 did have a higher slump value, but the consistency of the mixture was still very thick and difficult to shovel and/or scoop. MIX 2 had a high slump value because it demonstrated properties of self-consolidating concrete, but it was too thick to be easily used in construction.

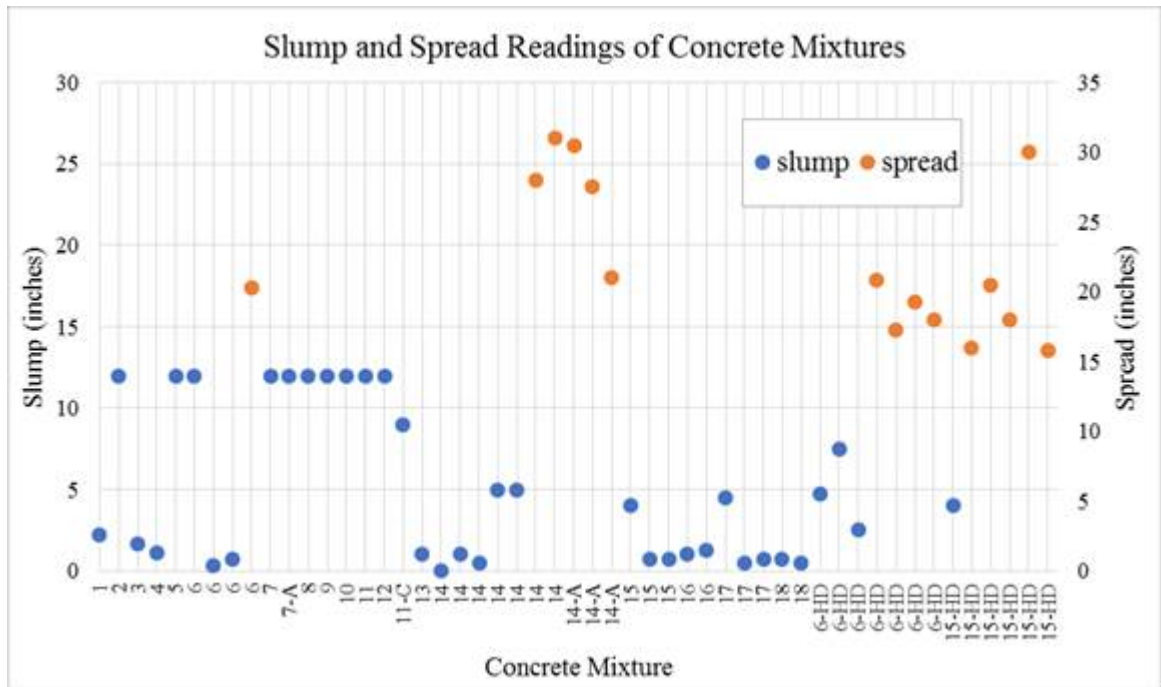

Figure 5-8: Spread and Slump Readings of Concrete Mixtures

At the other w/cm ratio extreme MIX 9 – MIX 12 all had high slump values that exceeded the limits of the test (spread tests should have been run). These were the concrete mixtures with a w/cm ratio equal to 0.32. Although these mixtures were very flowable, strength was compromised due to segregation that occurred in these concrete mixtures.

As previously mentioned, either 1/2” coarse aggregate, 3/8” coarse aggregate or a combination of both were used in the concrete mixtures of this project. In general, the trial batch concrete mixtures which contained 3/8” coarse aggregate, either combined with 1/2” coarse aggregate or as the sole coarse aggregate size, had poor consistencies. MIX 13, MIX 14, MIX 16 and MIX 18 were the trial batch concrete mixtures which contained 3/8” coarse aggregate. As seen in Figure 5-8, these trial batch concrete mixtures achieved low slump values, mostly around 1 inch.

### 5.2.2 Set Time

Set time penetration tests were executed as described in Section 4.5.2. The set time was measured for the two selected concrete mixtures as well as various other trial batch concrete mixtures. The penetration resistance of each concrete mixture over time is presented in Figure 5-9. As defined by ASTM C403 and depicted in Figure 5-9, the initial and final set time are defined as the time at which the penetration resistance reaches 500 and 4000 psi, respectively. Of all the concrete mixtures tested in this project, the earliest time that initial set occurred was 3.5 hours, indicating that the concrete mixture would start to lose its plasticity after 3.5 hours.

The trial batch concrete mixtures are shown in a gray scale, and the two selected concrete mixtures are shown in shades of blue in Figure 5-9. The shade of the lines representing trial batch concrete mixtures indicates the amount of fly ash that was used as a cement replacement. The darker the line, the greater the percent fly ash replacement, where the lightest lines contain 0% fly ash replacement and the darkest lines contain 25% fly ash replacement, excluding the two selected mixtures shown in blue. As shown in Figure 5-9, the initial and final set times were extended with a higher percentage of fly ash. These results are consistent with other sources found in the literature, as discussed in Chapter 2.

Both the initial and final set times of MIX 6-HD were about 2.5 hours shorter than those of MIX 15-HD. It is possible that this difference was unique to the particular batches mixed when the set time tests were run on these concrete mixtures. As discussed in the previous section, there was great variability in the consistencies of the selected concrete mixtures. The particular MIX 6-HD batch mixed for the set time test had a slump of 3 inches, meaning it was quite stiff and thick. A slump of 3 inches was the lowest value recorded for any MIX 6-HD batch. The particular batch that was mixed for MIX 15-HD when the set time was recorded had a spread of 16 inches,

making this concrete mixture much more flowable than MIX 6-HD. A spread of 16 inches was somewhere in the middle of the consistency measurements taken for MIX 15-HD.

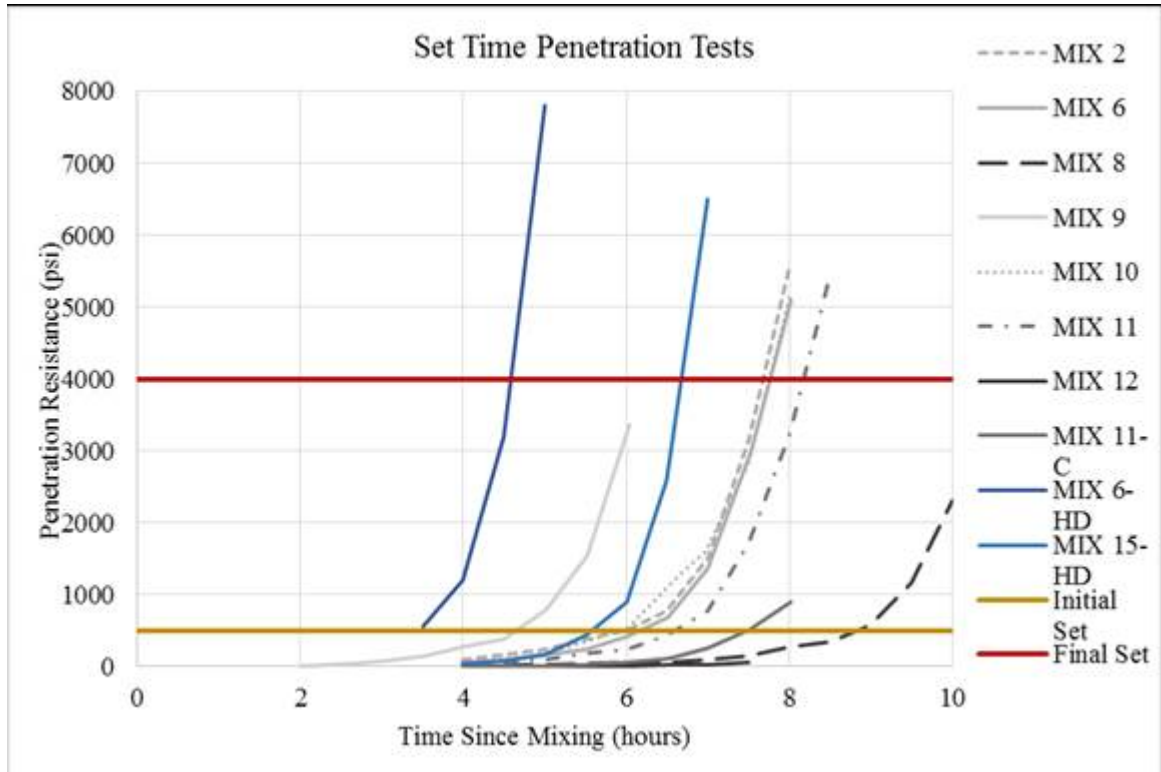

Figure 5-9: Set Time Penetration Tests Performed on Trial Batch and Selected Concrete Mixtures

Since MIX 6-HD had a thicker initial consistency than MIX 15-HD, it started out with a higher penetration resistance, as shown in the early penetration resistance readings in Figure 5-9. Overall, MIX 6-HD batches did have thicker consistencies than MIX 15-HD batches, but the average difference between the two selected concrete mixtures was not as extreme as these two batches were. Therefore, it is possible that if set time readings were taken on a larger sample of batches, there would not have been a 2.5-hour difference between MIX 6-HD and MIX 15-HD.

## 5.3 Additional Testing

### 5.3.1 Air Content

The air content was measured for the two selected concrete mixtures as well as some trial batch concrete mixtures, as shown in Figure 5-10. The air contents of the trial batch concrete mixtures are shown in orange and the air contents of the two selected concrete mixtures are shown in green. The air content was somewhere in the range of 1 to 3.5% for all concrete mixtures that were measured. The trial batch concrete mixtures in which air content was measured were MIX 6, 14, 15, 16, 17 and 18. The mix designs of each of these trial batch mixtures are discussed in Section 3.3.1 and reported in Appendix B. Of the trial batch concrete mixtures where air content was measured, MIX 6 and MIX 14 were the only two which had a  $V_{\text{paste}}/V_{\text{voids}}$  ratio equal to 1.75. MIX 15 and MIX 16 had a  $V_{\text{paste}}/V_{\text{voids}}$  ratio equal to 1.50 and MIX 17 and MIX 18 had a  $V_{\text{paste}}/V_{\text{voids}}$  ratio equal to 1.25. As seen in Figure 5-10, the trial batch concrete mixtures with a  $V_{\text{paste}}/V_{\text{voids}}$  ratio equal to 1.75 had air contents which were significantly higher than those with a lower  $V_{\text{paste}}/V_{\text{voids}}$  ratio. This is most likely caused by the higher paste content in these concrete mixtures. However, the trend did not continue with lower  $V_{\text{paste}}/V_{\text{voids}}$  ratios. There was no difference seen in air contents between trial batch mixtures with a  $V_{\text{paste}}/V_{\text{voids}}$  ratio equal to 1.5 and trial batch mixtures with a  $V_{\text{paste}}/V_{\text{voids}}$  ratio equal to 1.25.

The two selected concrete mixtures, MIX 6-HD and MIX 15-HD had average air content values of 1.7 and 1.9 %, respectively. Both of these concrete mixtures had air contents that were lower than the trial batch mixtures, on average. The only difference between MIX 6 and MIX 6-HD as well as MIX 15 and MIX 15-HD is the increased dosage of high-range water reducer used in MIX 6-HD and MIX 15-HD. As noted in Section 2.1.4.1 of the literature review, high-range water reducers typically increase the amount of air entrained in concrete. This contradicts the



results presented in Figure 5-10. In Table 5-6, it can be seen that by adding a greater dosage of HRWR to MIX 6, the entrapped air, on average, dropped by 1.3%, and by adding a greater dosage of HRWR to MIX 15, the average entrapped air did not change significantly.

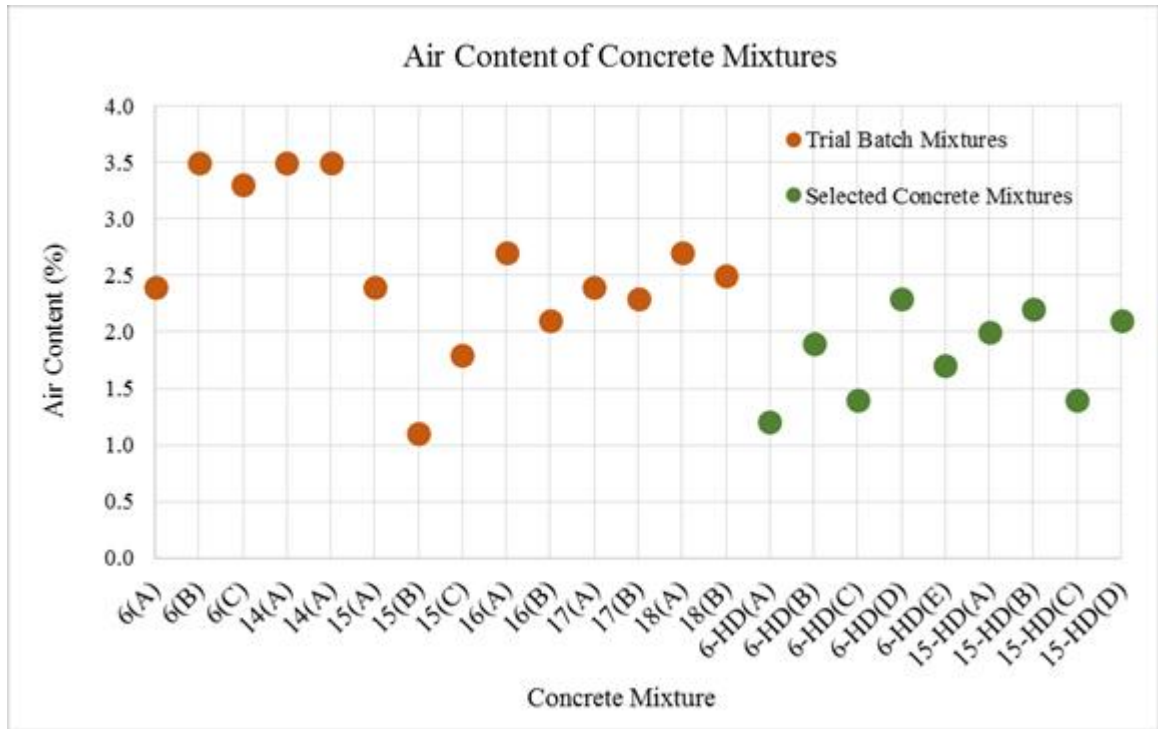

Figure 5-10: Air Content of Trial Batch and Selected Concrete Mixtures

In general, the air contents found for the concrete mixtures in this project are low. As shown in Table 2-2, the desired air content reported by pre-casters and DOT representatives is 3.0 to 7.0% for adequate freeze-thaw resistance. Additionally, ACI 211.1 states that for concrete with extreme exposure, such as concrete used for accelerated bridge construction closure pours, the air content should be as follows: 7.0% for concrete containing 1/2" coarse aggregate and 7.5% for concrete containing 3/8" aggregate. All of the measured air contents in this project were well below these values, including the two selected concrete mixtures. However, a study performed by

Kurtz and Constantiner showed that concrete containing superplasticizers, or concrete containing HRWR, can be freeze-thaw durable with air void system requirements that are less stringent than those for conventional concrete (Kurtz and Constantiner 2004). It has also been shown that concrete mixtures with low w/cm ratios and high compressive strengths, such as two selected concrete mixtures, have greater durability and resistance to scaling perhaps because of lower porosity.

Table 5-6: Air Content of Two Selected Mixtures with and without HRWR Dosage Change

Concrete Mixture	Average Air Content (%)
MIX 6	3.0
MIX 6-HD	1.7
MIX 15	1.8
MIX 15-HD	1.9

Although air content can be an indicator of the freeze-thaw resistance of concrete, an evaluation of freeze-thaw resistance (ASTM C1543 or ASTM C672) of the selected concrete mixtures would have to be performed to fully understand the durability of the concrete mixtures. A full list of air content readings in a tabulated format is reported in Appendix C.

### 5.3.2 Bar Pullout

The bar pullout test, as specified in ASTM A944, was executed on the two selected concrete mixtures, MIX 6-HD and MIX 15-HD. Both of the selected concrete mixtures were

tested with two epoxy coated Grade 60 bar sizes, No.4 and No. 6. Seven specimens in total were tested, the test specimen label along with the concrete mixture and bar size used for each is tabulated in Table 5-7. The bar pullout test was used to determine the strength of the bond between concrete and steel reinforcement. In each specimen, the potential failure modes could be by yielding of the test bar (steel reinforcement yield), cracking of concrete, bond failure between the concrete and steel reinforcement, or a combination of the three modes. Ideally the specimen would fail due to yielding of steel reinforcement, demonstrating that the concrete formed a strong enough bond with the steel reinforcement to prevent bond failure and the concrete was strong enough to prevent splitting from occurring.

Table 5-7: Bar Pullout Test Specimen Labels and Results

Test Specimen	Bar Size	Concrete Mixture	Max Load Resisted (kips)	Bar Slip Occurred?
6-HD-4(A)	No.4	MIX 6-HD	19.4	No
6-HD-4(B)			21.7	
6-HD-4(C)			22	
15-HD-4(A)		MIX 15-HD	18.4	
15-HD-4(B)			17.6	
6-HD-6		No.6	MIX 6-HD	
15-HD-6	MIX 15-HD		30.0	

As seen in Table 5-7, there were five specimens tested using No.4 bars and two specimens tested using No.6 bars. The nominal yield load for the Grade 60 No.4 and No.6 bars is 12 kips and 26.4 kips, respectively. As shown in Table 5-7, the load reached by each specimen containing a No.4 test bar was greater than 12 kips and the load reached by each specimen containing a No.6 test bar was greater than or equal to 26.4 kips. This means that all specimens reached a load that exceeded the nominal yield stress of the bar.

All No.4 test bar specimens failed by bar fracture except 6-HD-4(C), which was not fully tested to failure due to test setup limitations. Test specimen 6-HD-4(C) was the first bar pullout specimen to be tested (third to be cast), so the test setup was altered after this test to be able to test to a higher load and reach ultimate failure in the other No.4 test bar specimens. Each of the No.4 test bar fractures occurred at the location where the bars had been threaded to connect with a Lenton Terminator, as seen in Figure 5-11. Concrete cracking was also observed in each No.4 test bar specimen, where a concrete wedge formed at the loaded end, as shown in Figure 5-12. The measured bar slip for each specimen containing a No.4 bar was extremely small, fluctuating around 0.0005 inches, so it was considered negligible. This observation indicated that No.4 test bar specimens did not experience any bar slip.

All No.4 test bar specimens had a concrete compressive strength equal to 3500 psi or greater at the time of testing, which occurred at 12 hours of curing or later. The concrete strength at 12 hours of curing with the two selected concrete mixtures, MIX 6-HD and MIX 15-HD would not be less than 3500 psi. Therefore, it can be concluded that if the MIX 6-HD or MIX 15-HD concrete has been curing for at least 12 hours, bar pullout test specimens with No.4 test bars will reach the nominal yield strength of the test bar.



Figure 5-11: Typical Failure of Bar Pullout Tests with No.4 Test Bar



Figure 5-12: Concrete Cracking in Bar Pullout Tests with No.4 Test Bar

In contrast to specimens containing No. 4 bars, test specimens containing No.6 test bars did experience bar slip. There were two specimens tested containing a No.6 test bar. One

comprised of MIX 6-HD, test specimen 6-HD-6 and the other comprised of MIX 15-HD, test specimen 15-HD-6. The total bar slip that occurred in test specimen 6-HD-6 was about 0.0035 inches, where the maximum load reached about 26 kips. The total bar slip that occurred in specimen 15-HD-6 was slightly less, equaling about 0.0025 inches, and the maximum load reached was slightly more at about 30 kips. The load versus displacement plots for each of these specimens is provided in Figure 5-13. The slope of the curve representing specimen 15-HD-6 is greater than the slope of the curve representing specimen 6-HD-6, indicating that greater force was required to cause the same amount of slip in specimen 15-HD-6 than specimen 6-HD-6.

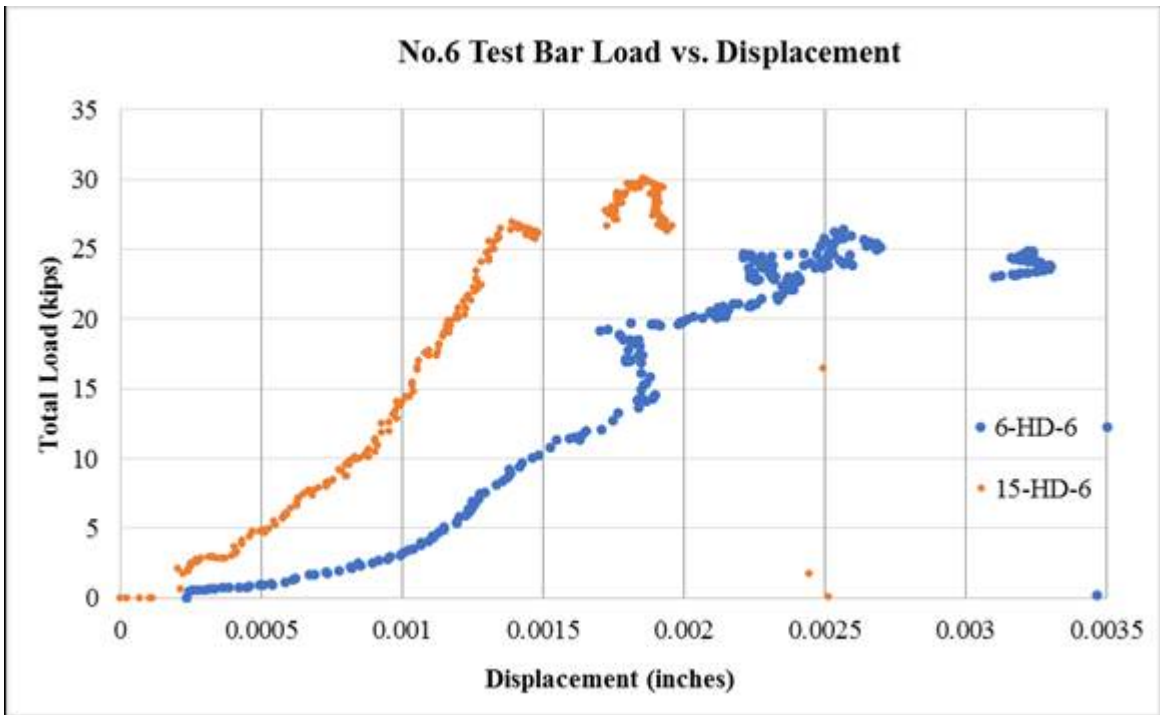

Figure 5-13: Load versus Displacement Plots for Bar Pullout Specimens Containing No.6 Test Bars



Figure 5-14: Concrete Cracking of Test Specimen 6-HD-6

The compressive strength of specimens 6-HD-6 and 15-HD-6 were both greater than 4000 psi at the time of testing. Concrete cracking was also observed in test specimens 6-HD-6 and 15-HD-6. Concrete cracking developed near the location of the test bar and then propagated away from the test bar. The cracks that formed in specimen 6-HD-6 were similar to those that formed in specimens containing No.4 bars, where a concrete wedge formed at the loaded end of the specimens, depicted in Figure 5-14 and in Figure 5-15. The ultimate failure mode could not be concluded for specimens containing No.6 test bars because the specimens were not tested to failure due to test setup limitations, however, each specimen reached the nominal yield strength of the test bar.



Figure 5-15: Concrete Cracking of Test Specimen 15-HD-6

### 5.3.3 Confined Shrinkage

As discussed in Section 3, confined shrinkage was evaluated for the two selected concrete mixtures. An AASHTO specification for ring shrinkage tests, AASHTO PP 34-99, was followed while executing this test. Details about the test setup and procedures can be found in Section 4.5: Concrete Testing Procedures. Four confined shrinkage tests were run for MIX 6-HD and three confined shrinkage tests were run for MIX 15-HD. There was also a confined shrinkage test run on a “normal” concrete mixture. The normal concrete used for this project was a 4000 psi Mass Highway Department mix obtained from a local concrete ready-mix plant. The mixture design is as defined in Table 5-8. The confined shrinkage test was performed on normal concrete so that the results from a normal concrete mixture could be compared to the two selected concrete mixtures, MIX 6-HD and MIX 15-HD, developed for this research project.

The results from each set of confined shrinkage tests are summarized in Figure 5-16 for MIX 6-HD and Figure 5-17 for MIX 15-HD. The following information is provided in each plot: the recorded strain over time, time to visually observed cracking and the 12-hour compressive



strength. Both of the plots provide results for all confined shrinkage tests executed for the particular concrete mixture design. For MIX 6-HD, there are results from four tests, and for MIX 15-HD there are results from three tests. Each of the tests are defined by an individual color, where the same color is used to plot strain, time to cracking and compressive strength for one test. The specific test specimen which corresponds to each color can be found in Figure 5-16. As seen in Figure 5-16 and Figure 5-17, there are four strain curves plotted for each specimen; each curve indicates the strains recorded for one strain gauge. As discussed in Section 4.5.1, there are four strain gauges per specimen, bonded equidistantly around the inner steel ring. A sudden increase in strain in the readings (from a high negative value to near zero) corresponds to cracking since these values are measured directly in the steel ring, which is being compressed as the concrete surrounding it is shrinking.

Table 5-8: Normal Concrete Mix Design Used for Confined Shrinkage Test

<b>Component</b>	<b>Material</b>	<b>Normal Concrete</b>	<b>Units/yd<sup>3</sup></b>
Coarse Aggregate	3/4" Crushed Stone	1270	lb.
Fine Aggregate	Concrete sand	1950	lb.
Cement	Type I/II Portland Cement	498	lb.
Supplementary Cementitious Material	Slag	175	lb.
Free Water	N/A	32.5	gal.
Chemical Admixtures	Mid-Range Water Reducer	34	fl. oz.
	Air Entrainer	5	fl. oz.

As shown in Figure 5-16, the initial strain rate was about the same for each of the four MIX 6-HD specimens tested. In 7 days, the strain in each specimen had reached approximately -75 microstrain ( $\mu\epsilon$ ), with each curve following a similar path to reach this value. Once each specimen had been curing for about 7 days, the strain rate decreased and eventually reached a plateau. The strain in each specimen did not change significantly until cracking occurred and the tension in the ring was released. This can be clearly seen with Ring 2, shown in green, where the strain in each gauge of the specimen remains equal to about -100  $\mu\epsilon$  for about 50 days, until cracking occurred.

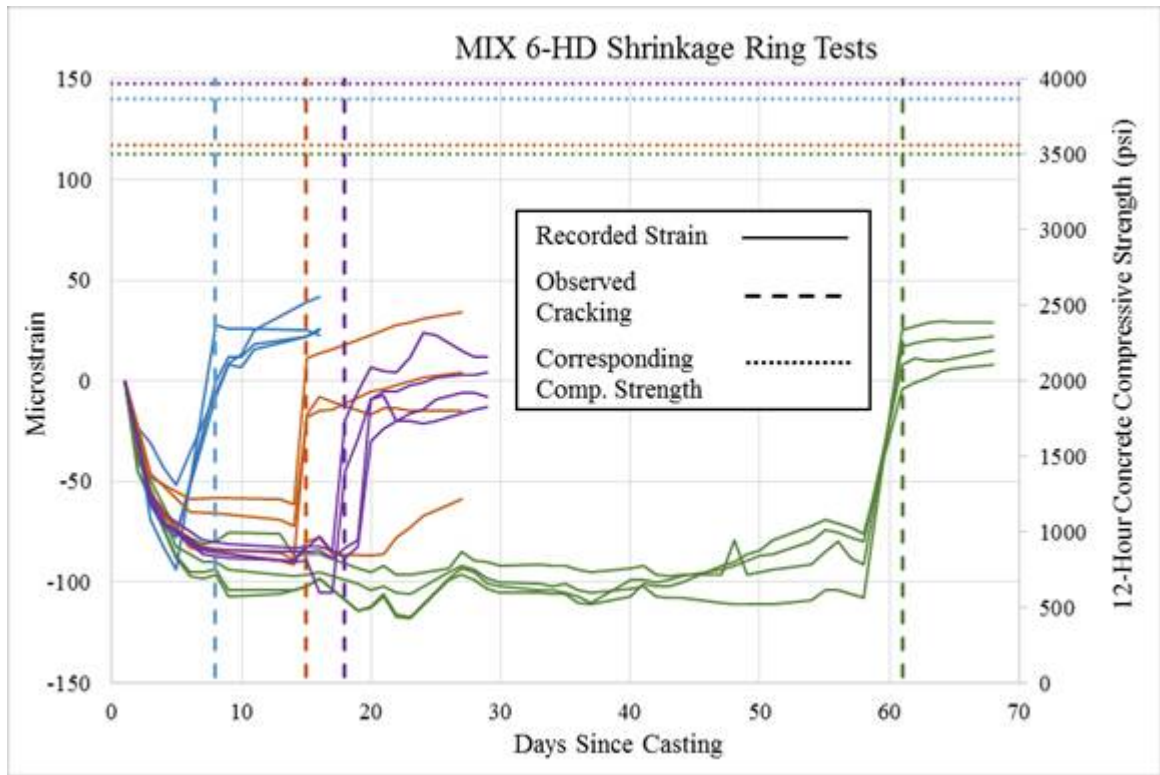

Figure 5-16: Confined Shrinkage Test Results for MIX 6-HD, Including Time to Cracking, Strain versus Time and 12-Hour Compressive Strength

Table 5-9: Summary of Confined Shrinkage Specimen Parameters

Concrete Mixture	Test Specimen	Color Indication on Plots	Time to Cracking (Days)	Average Environment Conditions		Compressive Strength (psi)	
				Temp. (°F)	Relative Humidity (%)	12 Hour	24 Hour
MIX 6-HD	Ring 1	Orange	15	74.1	24.0	3570	5660
	Ring 2	Green	61	72.5	48.0	3500	5870
	Ring 3	Blue	8	70.4	27.9	3870	5710
	Ring 4	Purple	18	70.6	22.4	3970	5340
MIX 15-HD	Ring 1	Orange	17	70.3	22.6	3670	5140
	Ring 2	Green	23	71.5	59.2	3700	5360
	Ring 3	Blue	36	74.1	24.0	3930	5350

As stated in AASHTO PP 34-99, a strain increase of more than 30  $\mu\epsilon$  in one or more gauges usually indicates cracking. The day that cracking was visually observed in each of these specimens was also the day where the strain increased in each gauge by approximately 40 to 100  $\mu\epsilon$ . As seen in Figure 5-16, one gauge in Ring 1, shown in orange, does not experience a sudden increase in strain, unlike the other strain gauges. The gauge does show an overall increase of about 30  $\mu\epsilon$ , but it is gradual and does not begin to increase until 5 days after cracking. It is possible that the concrete was bonded to the steel ring at this location and continued to create a

compressive stress in the steel ring after cracking and until the bond between the concrete and steel rings was broken.

Although the rate of strain decrease was similar for all specimens, the time to cracking varied greatly for the four MIX 6-HD specimens tested. Ring 3, shown in blue, had a time to cracking of 8 days and Ring 2, shown in green, had a time to cracking of 61 days. Time to cracking of Ring 2 was almost 8 times that of Ring 3. Factors that may have affected the time to cracking were evaluated, such as the temperature and relative humidity of the testing room and strength of concrete. Depicted in Figure 5-16, and also reported in Table 5-9 are the compressive strengths of each specimen after 12 hours of curing. It can be seen that there was no correlation between the strength and time to cracking of each specimen. The 12-hour compressive strength values of the four MIX 6-HD specimens were all very similar with a coefficient of variation of only 5%. Also, the specimen which had the longest time to cracking, Ring 2, also had the lowest 12-hour compressive strength, demonstrating that greater strength did not hinder shrinkage cracking.

The temperature was regulated during each of the tests; therefore, the average room temperature for each test was very similar, as shown in Table 5-9, and did not affect the time to cracking. The relative humidity varied with each test. The average relative humidity for each test is reported in Table 5-9. It can be seen that for Ring 1, Ring 3 and Ring 4, the relative humidity was similar with values of 24.0, 27.9 and 22.4%, respectively. However, Ring 2 had a relative humidity equal to 48.0%. It would appear that this could be a cause for the significantly greater time to cracking seen in Ring 2, but as will be discussed later, the results from MIX 15-HD confined shrinkage specimens disproves this theory.

Consequently, the variation in time to cracking of MIX 6-HD specimens is attributed to the lack of homogeneity that exist within the concrete specimens which could affect initial formation of micro-cracks as well as the location of aggregate particles that may affect propagation of these cracks.

By observing Figure 5-17, it can be seen that the initial strain rate of MIX 15-HD specimens was similar to that of MIX 6-HD specimens. Again, the strain decreased to about  $-75 \mu\epsilon$ , following a parabolic path. It can also be seen in Figure 5-17 that the strains in MIX 15-HD specimens have a slightly larger spread than those of MIX 6-HD specimens. The spread between individual strain gauges indicates that the compressive forces generated in the concrete ring and transferred to the steel ring were not perfectly uniform. Similar to the specimens from MIX 6-HD, the strains in these specimens reached a plateau after getting to about  $-75 \mu\epsilon$ , and maintained a fairly constant strain until cracking occurred. Also, similar to MIX 6-HD specimens, MIX 15-HD specimens experienced a sudden change in strain in the range of 40 to  $85 \mu\epsilon$  upon cracking. All of the specimens from both concrete mixtures experienced a strain increase greater than  $30 \mu\epsilon$ , which as mentioned is the minimum value to indicate cracking, suggested by AASHTO PP 34-99.

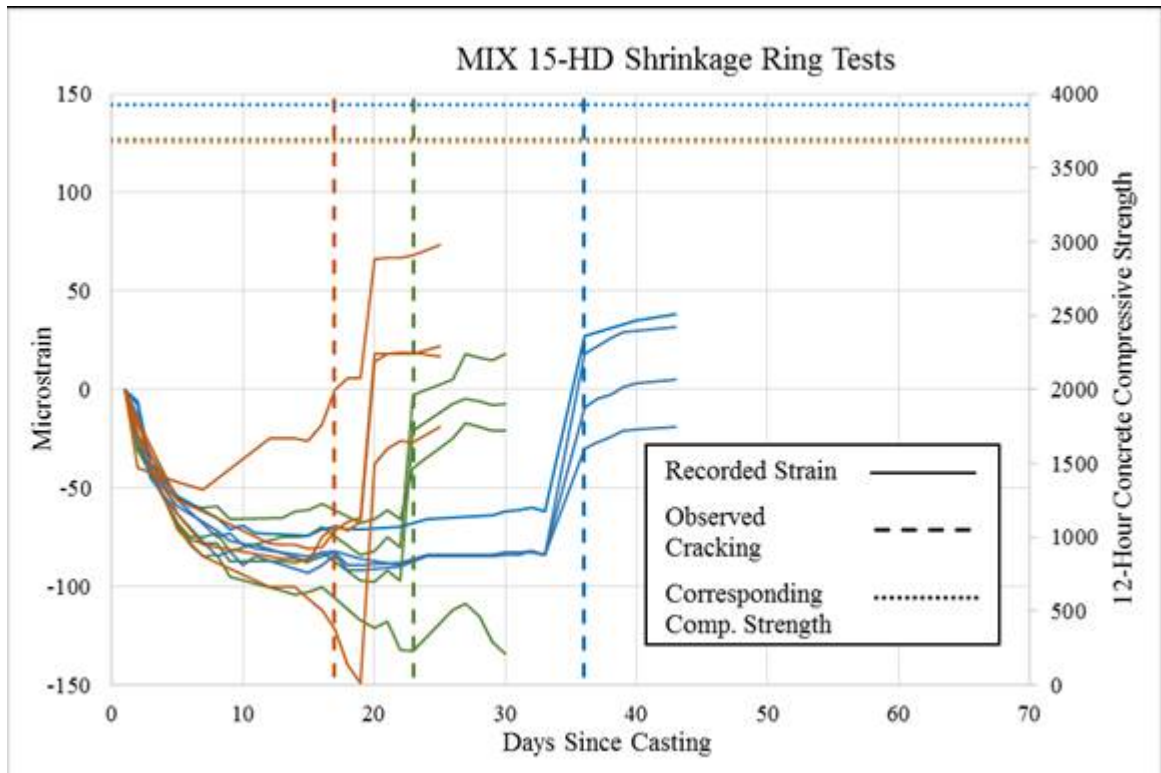

Figure 5-17: Confined Shrinkage Test Results for MIX 15-HD, Including Time to Cracking, Strain versus Time and 12-Hour Compressive Strength

One of the Ring 2 strain gauges, shown in green in Figure 5-17, did not experience a sudden increase in strain upon cracking. There was only a slight increase, and then the strain continued to decrease until the monitoring of the ring ceased. This behavior is similar to that of a MIX 6-HD, Ring 1 strain gauge. Again, this was most likely due to the concrete bonding to the steel at the location of that particular strain gauge. If the concrete ring were bonded to the steel ring at this location, and concrete was continuing to experience shrinkage, this decrease would occur.

The time to cracking also varied for MIX 15-HD specimens, but not as drastically as it did with MIX 6-HD specimens. The range in time to cracking values for MIX 15-HD was 19

days, as shown in Table 5-9 and in Figure 5-17. This is much smaller than the range of 53 days for MIX 6-HD specimens. As previously discussed, the temperature of the testing room and compressive strengths of the specimens were not reasons for variation in time to cracking. The relative humidity of the testing room did show a potential correlation with time to cracking based on results from MIX 6-HD specimens. However, with MIX 15-HD specimens, this trend was negated. As shown in Figure 5-17, the shortest time to cracking for MIX 15-HD specimens was with Ring 1, shown in orange. The longest time to cracking for MIX 15-HD specimens was with Ring 3, shown in blue. The relative humidity in the testing room while Ring 1 and Ring 3 were running was about equal, with average relative humidity values equal to 22.6 and 24.0%, respectively.

Ring 2, shown in green, which had a time to cracking greater than Ring 1, but less than Ring 3, had an average test room relative humidity equal to 59.2%. Although the average relative humidity of the test environment was significantly higher for Ring 2, it was not correlated with the time to cracking. Therefore, the relative humidity of the test room was not a cause for differences in time to cracking of confined shrinkage specimens. As mentioned, the differences in time to shrinkage cracking is attributed to variations in imperfections within each concrete ring specimen.

When cracking was observed in the confined shrinkage concrete rings, it was visible along the outer edge of the ring. Since the top of the ring was sealed during testing, the penetration of the crack through the thickness of the ring could not be seen at the time of its formation. However, once the test was complete and the seal on the top of the ring was removed, it could be seen that the crack extended through the full thickness of the ring as expected. A typical crack formation is shown Figure 5-18. The crack shown in this image is outlined in black

to make it more visible. The three marks located equidistantly up the height of the ring are the locations where the crack width was measured daily. The crack width was taken to be an average of these three width recordings.



Figure 5-18: Typical Crack Formation in a Confined Shrinkage Ring

When shrinkage cracking occurred in the confined shrinkage specimens, either one or two cracks would form. Single cracking is depicted in Figure 5-19 and double cracking is shown in Figure 5-20. When double cracking occurred in a specimen, the cracks would form on opposite sides of the ring, located about 180 degrees apart.





Figure 5-19: Shrinkage Cracking Occurring as One Crack in a Confined Shrinkage Ring



Figure 5-20: Shrinkage Cracking Occurring as Two Cracks in a Confined Shrinkage Ring

The measured crack width for each MIX 6-HD confined shrinkage specimen is shown in Figure 5-21. Again, the color of each curve corresponds to a specific specimen, as defined in Table 5-9. For specimens which formed two cracks, the crack width refers to the sum of both crack widths. The cracks widths were measured for two weeks after they formed, as specified by AASHTO PP 34-99. However, in about 7 to 9 days, the crack width stopped increasing; therefore, this plot provides crack width data from day 0 to day 10. As shown in Figure 5-21, the total increase in crack width was equal to about 0.01 inches for all MIX 6-HD specimens.

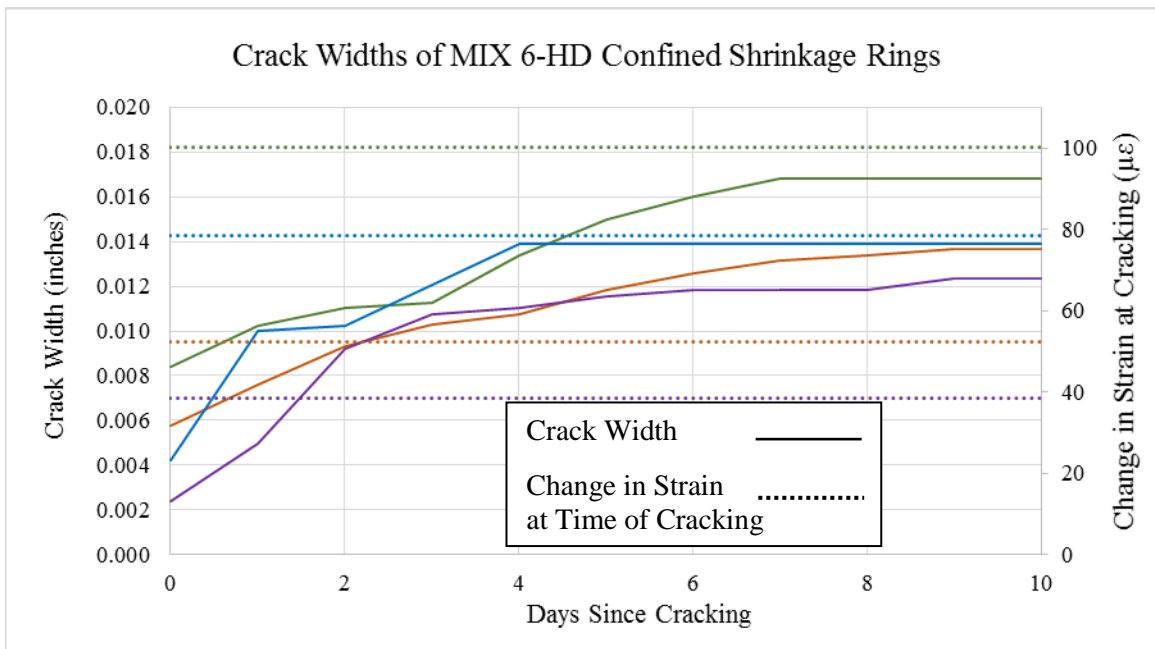

Figure 5-21: Crack Widths of MIX 6-HD Confined Shrinkage Specimens Plotted with Change in Strain that Occurred at Cracking

Also plotted in Figure 5-21 are the strain increases which occurred in each specimen at the time of cracking. It can be seen that there is correlation between the final crack width and the change in strain that occurred at cracking. The specimen with the largest crack width also had the largest increase in strain at cracking. Similarly, the specimen with the smallest crack width also

had the smallest increase in strain at cracking. The other two specimens also followed this trend. This is most likely because the specimens with larger crack widths experienced a greater release of stresses at the time of cracking which would have higher impact on the change in strain.

The crack widths and increase in strain at cracking for each MIX 15-HD specimen are plotted in Figure 5-22. The specimen which corresponds to each color plotted in this figure are tabulated in Table 5-9. The crack widths were recorded for two weeks after cracking was first observed. Similar to Figure 5-21, Figure 5-22 only provides crack width data until day 10 after cracking. Again, this is because the crack widths were not increasing throughout the full two week recording period. For Ring 1, and Ring 2, shown in orange and green, respectively, the crack width stopped increasing 4 days after time of cracking. Ring 3, shown in blue stopped increasing even sooner at only 2 days after cracking. All cracks in confined shrinkage specimens from MIX 15-HD stopped growing sooner than those from MIX 6-HD.

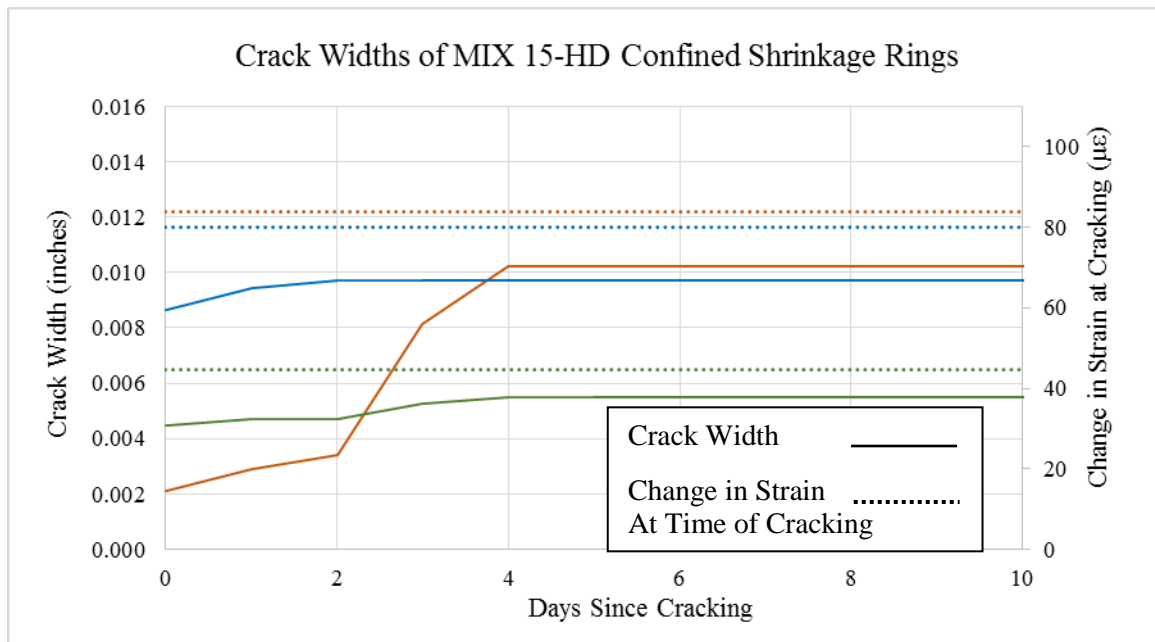

Figure 5-22: Crack Widths of MIX 6-HD Confined Shrinkage Specimens Plotted with Change in Strain that Occurred at Cracking

The increase in crack width varied with MIX 15-HD specimens, unlike MIX 6-HD specimens. Ring 2 and Ring 3 each had a total crack width increase of about 0.002 inches. The shrinkage crack in Ring 1 increased by about 0.008 inches, which was 4 times greater than the increase seen in Ring 2 and Ring 3 cracks. Although the crack in Ring 1 increased much more than the cracks in Ring 2 and Ring 3, it did not have a final crack with significantly higher than the others. This is because the initial crack width observed in this specimen was quite small. The largest increase in the Ring 1 crack width occurred starting at day 2 after initial cracking. This is consistent with the results shown in Figure 5-17, where the sudden increase in strain occurred 2 days after cracking was visually observed, unlike other specimens where it occurred on the day of cracking. This is most likely because the shrinkage crack in this specimen started to develop on the outside edge of the concrete ring where it was visible and then propagated towards the center.

When a shrinkage crack starts to develop in each of these specimens, a spike in the strains would not have occurred immediately. It would not have occurred until the shrinkage crack had propagated across the entire width of the ring. This can be the result of a portion of the concrete ring thickness remaining un-cracked at the crack location that provided resistance to shrinkage stresses creating tension in the concrete prior to complete cracking. When a crack had propagated across the full width of the ring, the crack would appear visible and the crack width would increase significantly. It is likely that MIX 15-HD, Ring 1 had a crack formed at the outer edge and the specimens all had cracks that started to develop somewhere other than the outer edge and were not visible until the crack had fully propagated through the ring thickness.

The specimens from MIX 15-HD had the same correlation between crack width and change in strain at cracking as MIX 6-HD specimens, where magnitude in strain change related directly with crack width. The reported strain change for Ring 1, as shown in Figure 5-22, was

taken at 2 days after cracking was visually observed because no significant change in strain was measured the day that cracking was first observed. The increase in strain that was measured 2 days after observed cracking was thought to be a better value to use for comparative purposes.

The test results from the confined shrinkage ring specimen fabricated using a normal concrete mixture, as defined in Table 5-8, are presented in Figure 5-23. The strain rate generated from shrinkage in the normal concrete test specimen was similar to the strain rates observed in specimens fabricated with MIX 6-HD and MIX 15-HD, but appeared to follow a slightly more linear trend during the initial days of measurement. The average strain in the steel ring of this specimen reached about  $-95 \mu\epsilon$ . The strain plateau after approximately 10 days did not extend as long as in other specimens before cracking occurred, characterized by a strain increase of about  $40 \mu\epsilon$ . The time to cracking of the normal concrete mixture was 13 days. This corresponds to a shorter time to cracking than determined for the majority of tests involving MIX 6-HD and MIX 15-HD specimens, as shown in Figure 5-23.

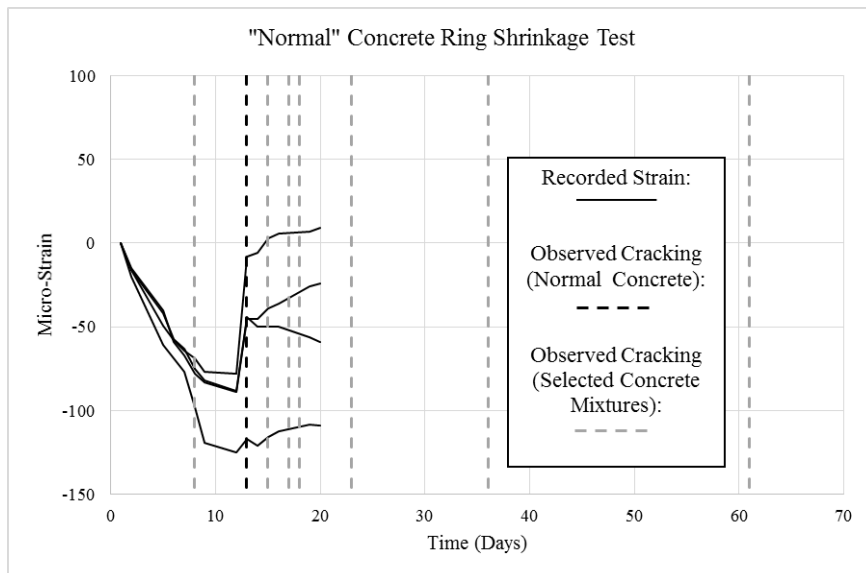

Figure 5-23: Confined Shrinkage Test Results for Normal Concrete, Including Time to Cracking Strain versus Time

The results from the specimen with normal concrete mixture are consistent with results from a study performed by See et al. (2003) which are illustrated in Figure 5-24. In this study, normal concrete and high-performance concrete, both with and without shrinkage reducing admixture were tested using a confined shrinkage apparatus following AASHTO PP 34-99. The normal concrete tested in this study cracked after 17 days of drying, close to the 13-day time to shrinkage cracking observed in the normal concrete specimen in this project.

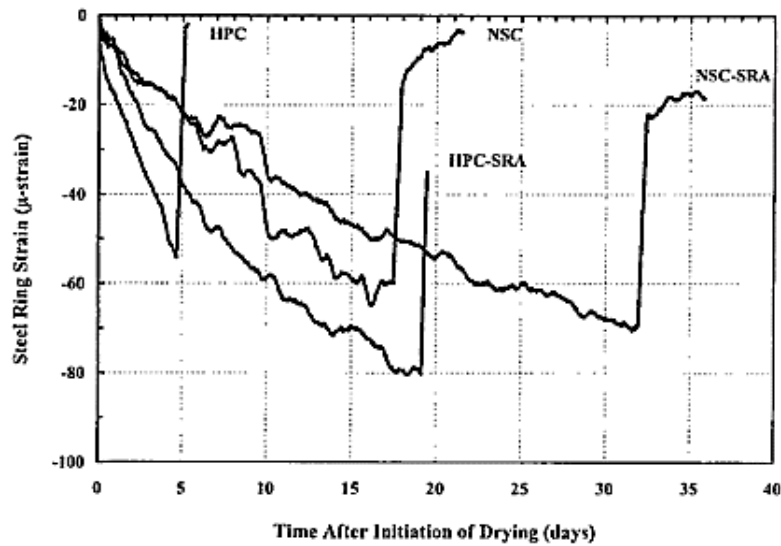

Figure 5-24: Ring Shrinkage Test Results of Normal Concrete and High Performance Concrete with and without Shrinkage Reducing Admixture (See et al. 2003)

The high-performance concrete (HPC) reported in the study by See et al. (2003) is a type of concrete that has properties similar to concrete previously been used for concrete closure pour applications. As shown in Figure 5-24 and discussed in Section 2, HPC has typically demonstrated a shorter time to shrinkage cracking compared with normal strength concrete perhaps because of the higher cement content. The HPC specimen in the study performed by See et al. (2003) had a time to cracking of only 5 days. Therefore, the selected concrete mixtures in this project MIX 6-HD and MIX 15-HD, which are an alternative to HPC for concrete closure

pour applications demonstrated a better performance in terms of shrinkage cracking with time to cracking values all much greater than 5 days. It should also be noted that in the study performed by See et al., the strain values reached were in the range of -50 to -80  $\mu\epsilon$  prior to cracking, which are on average less than those measured in this project. The strain values in the study by See et al, also did follow the same initial trend as the confined shrinkage specimens in this project and an unnoticeable strain plateau. These lower strain values as well as the linear trend the curves followed are consistent with the normal concrete and HPC in this study.

#### **5.3.4 Alkali Silica Reactivity**

As stated in the appendix of ASTM C1567, combinations of cement and/or cementitious material and aggregate that expand less than 0.10% at 16 days after casting are likely to have a low risk of deleterious expansion when used in concrete under field conditions. This is referring to the alkali-silica reactivity test specified in ASTM C1567 that was used for this research project because it involved a much shorter exposure period than other tests. As discussed in Section 4.5.1, alkali silica reactivity was evaluated for Source 2 coarse and fine aggregates in combination with Type III Portland Cement and Class F fly ash to reflect, as close as possible, the constituents used in the selected concrete mixtures.

A total of 12 specimens were cast, as described in Section 4.5.1, six that were designed to evaluate the potential for alkali silica reactions occurring with coarse aggregate and the six designed to evaluate the potential for alkali silica reactions occurring with fine aggregate. The length of each specimen was measured daily for 14 days, starting 2 days after casting. Based on these length measurements, the percent expansion was calculated for each specimen.

The average expansion that occurred with each aggregate type, coarse and fine, is shown in Figure 5-25. The average expansion seen with both aggregate sizes was less than approximately 0.001%. These expansions were much less than the 0.10% limit defined in ASTM C1567 to identify the potential for deleterious expansion. There were slight variations in the percent expansion values found throughout the 16-day period. It should be noted that Figure 5-25 shows expansion on a logarithmic scale; therefore, the variations that are shown in the plot are approximately equal to 0.001% of the specimen lengths and are likely caused by small particles that came between the gauge studs and length comparator. Therefore, based on these results, the cementitious material and aggregate combinations that exist within the tested concrete mixtures should not be a cause for deleterious expansion of concrete from alkali silica reactivity.

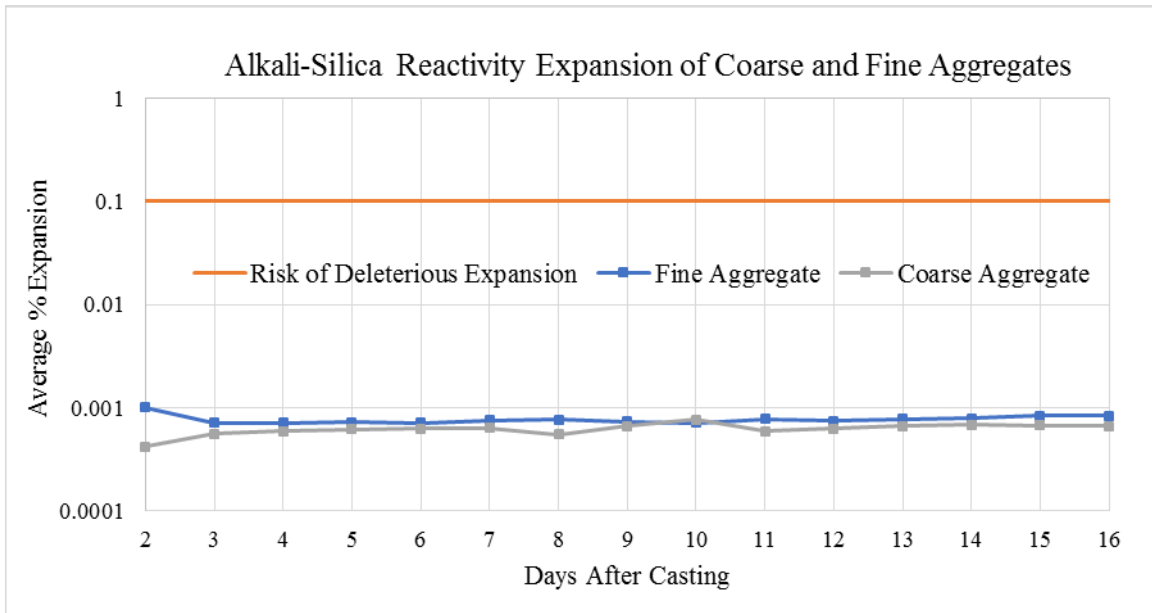

Figure 5-25: Expansion Alkali Silica Reactivity Test Specimens

### 5.3.5 Freeze-Thaw Durability

Fabrication of prisms to determine freeze-thaw durability were fabricated and prepared as described in Section 4.5.3.4. These specimens were then subjected to 300 cycles between freezing



and thawing temperatures at MassDOT laboratory facilities. The average concrete compressive strength at the time of initiation of freeze-thaw cycling was 12,100 psi. Compressive strength was determined testing companion cylinders that were cast at the same time as the prisms and were cured under the same conditions. Figure 5-26 illustrates the condition of the prisms after the first 36 cycles of freeze-thaw testing. The damage observed in prism BB occurred during shipping to the laboratory facilities, so no apparent damage could be seen after this limited number of cycles. Furthermore, the aspect of the prisms did not change significantly from the one observed in this figure.

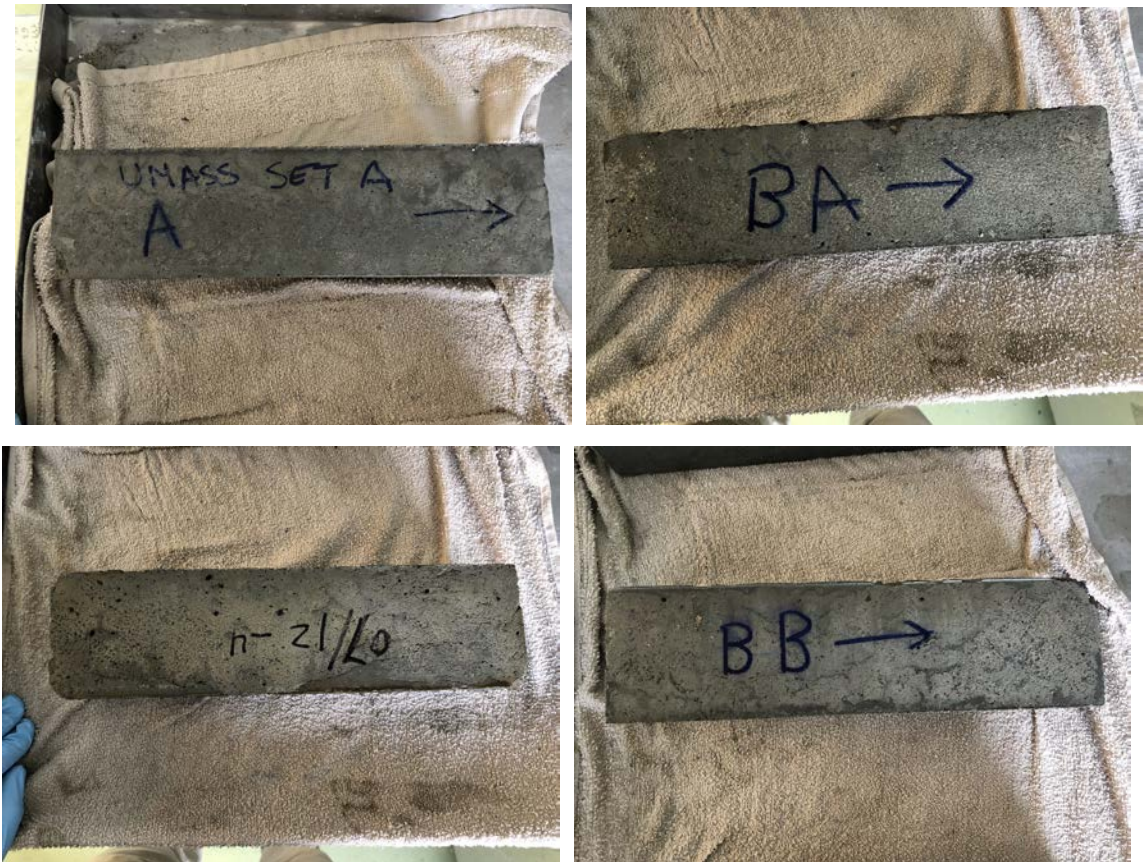

Figure 5-26: Condition of Sets of Prisms after 36 Cycles of Freeze-Thaw Testing

Measurements for fundamental transverse resonant frequency, length change, and mass change were conducted after every 36 cycles. Table 5-10 to Table 5-13 summarize the progression of measurements taken on the four prisms during freeze-thaw testing. The reduction in dynamic modulus of elasticity ( $\Delta P$ ) registered in Prism 2, Set B was much higher for the 72 and the 108 cycles than other readings taken in this prism (-21.1% and -13.9%, respectively). After the 140 cycle frequency readings for that prism returned to lower ranges. It can be observed that the maximum change in dynamic modulus of elasticity, neglecting the inordinately high values, were registered at 3.8% in Prism 2-Set A, after 212 cycles. This reading also decreased to values closer to the average after this cycle. The maximum change in length registered was 0.040% for Prism 1-Set A, while the maximum change in mass was registered at 0.25% for Prism 1, Set B. The average durability factors calculated for the two sets of prisms were 97.2% and 95.8% for sets A and B, respectively. The results of the freeze-thaw testing were acceptable.

Table 5-10: Summary of Freeze-Thaw Results – Prism 1-Set A

<b>Cycle</b>	<b>Frequency (Hz)</b>	<b><math>\Delta P</math> (%)</b>	<b>Length* (in.)</b>	<b><math>\Delta L</math> (%)</b>	<b>Mass (g)</b>	<b><math>\Delta M</math> (%)</b>
0	119.2		6.184	-	4243.0	-
36	119.0	0.3	6.196	0.005	4242.6	0.01
72	118.0	2.0	6.194	0.004	4241.8	0.03
108	117.6	2.7	6.202	0.007	4241.8	0.03
140	119.8	-1.0	6.200	0.006	4240.0	0.07
176	119.2	0.0	6.200	0.006	4239.0	0.09
212	118.0	2.0	6.235	0.020	4242.3	0.02
248	117.9	2.2	6.243	0.024	4243.5	-0.01
284	118.5	1.2	6.243	0.024	4242.9	0.00
300	117.3	3.2	6.283	0.040	4244.2	-0.03

\*Length measured between two points using a comparator;  $\Delta P$ ,  $\Delta L$ ,  $\Delta M$  represent change in frequency, length, or mass from the original reading, respectively.

Table 5-11: Summary of Freeze-Thaw Results – Prism 2-Set A

Cycle	Frequency (Hz)	$\Delta P$ (%)	Length* (in.)	$\Delta L$ (%)	Mass (g)	$\Delta M$ (%)
0	115.5	-	4.630	-	4099.0	-
36	114.5	1.7	4.632	0.001	4097.5	0.04
72	114.8	1.2	4.640	0.004	4096.5	0.06
108	114.4	1.9	4.650	0.008	4096.4	0.06
140	114.5	1.7	4.636	0.002	4095.2	0.09
176	114.8	1.2	4.645	0.006	4094.2	0.12
212	113.3	3.8	4.656	0.010	4093.9	0.12
248	114.1	2.4	4.665	0.014	4092.9	0.15
284	114.8	1.2	4.651	0.008	4092.2	0.17
300	114.1	2.4	4.659	0.012	4092.0	0.17

\*Length measured between two points using a comparator;  $\Delta P$ ,  $\Delta L$ ,  $\Delta M$  represent change in frequency, length, or mass from the original reading, respectively.

Table 5-12: Summary of Freeze-Thaw Results – Prism 1-Set B

Cycle	Frequency (Hz)	$\Delta P$ (%)	Length* (in.)	$\Delta L$ (%)	Mass (g)	$\Delta M$ (%)
0	99.9	-	4.780	-	4132.3	-
36	99.5	0.8	4.776	-0.002	4128.5	0.09
72	100.4	-1.0	4.798	0.007	4126.8	0.13
108	99.3	1.2	4.786	0.002	4126.4	0.14
140	97.5	4.7	4.785	0.002	4124.9	0.18
176	98.4	3.0	4.790	0.004	4123.0	0.23
212	98.6	2.6	4.800	0.008	4123.0	0.23
248	98.3	3.2	4.810	0.012	4122.4	0.24
284	98.4	3.0	4.796	0.006	4122.2	0.24
300	97.9	4.0	4.796	0.006	4122.1	0.25

\*Length measured between two points using a comparator;  $\Delta P$ ,  $\Delta L$ ,  $\Delta M$  represent change in frequency, length, or mass from the original reading, respectively.

Table 5-13: Summary of Freeze-Thaw Results – Prism 2-Set B

<b>Cycle</b>	<b>Frequency (Hz)</b>	<b><math>\Delta P</math> (%)</b>	<b>Length* (in.)</b>	<b><math>\Delta L</math> (%)</b>	<b>Mass (g)</b>	<b><math>\Delta M</math> (%)</b>
0	96.7	-	5.104	-	4286.1	-
36	95.8	1.9	5.104	0.000	4281.7	0.10
72	106.4	-21.1	5.122	0.007	4280.0	0.14
108	103.2	-13.9	5.117	0.005	4279.2	0.16
140	97.8	-2.3	5.112	0.003	4279.0	0.17
176	98.2	-3.1	5.118	0.006	4279.0	0.17
212	96.2	1.0	5.130	0.010	4278.6	0.17
248	94.6	4.3	5.143	0.016	4277.9	0.19
284	94.8	3.9	5.125	0.008	4276.7	0.22
300	94.5	4.5	5.138	0.014	4276.0	0.24

\*Length measured between two points using a comparator;  $\Delta P$ ,  $\Delta L$ ,  $\Delta M$  represent change in frequency, length, or mass from the original reading, respectively.

## 6 LARGE-SCALE LABORATORY TESTS

### 6.1 Overview

Laboratory tests were designed and implemented using Mix 23 in a narrow longitudinal closure pour connection of large-scale specimens representing structural bridge decks in the field. The specimens were tested one day after casting of the high early-strength concrete. Specimen design, fabrication, design strength, testing procedure, and test results are presented in this section. These tests were not intended to characterize the long-term cyclic performance of the connection; the objectives were to evaluate if the connection developed the required short-term strength (one day), and to document any distress that may occur because of loading at early ages.

### 6.2 Specimen Design

The test specimens were designed to represent typical deck portion of two adjacent deck bulb tee girders connected together through a longitudinal joint. The design was done following PCI Northeast Deck Bulb Tee Guidelines (NEDBT) in coordination with AASHTO LRFD Bridge Design Specifications. Drawings details for hooked bar connection from the guide provided guidance on the selection of closure pour width, dimensions for the deck panels, and steel reinforcement for the specimens. The guide indicated that the closure pour width generally varies from 12 in. to 24 in. and requires that the concrete closure pour material in the longitudinal section must be a mix with a minimum compressive strength of 4 ksi. Higher strength mixes may be used which could result in a narrow closure pour connection. Following this recommendation, the specimens in this research uses joint widths of 8 in. and 6 in. with the high early-strength concrete to determine the behavior of the specimens with a smaller joint.

Two specimens with similar dimensions were fabricated for testing. Each specimen consisted of two conventional concrete precast panels connected using a narrow closure pour that contains a triangular shear key filled with the closure pour material. Elevation view, joint section view, plan view, and reinforcement details of the specimens can be seen in Figures 6-1 through 6-4. Each panel was 44 in. long and 8 in. deep. Panels for specimen 1 were 34 in. wide connected together with the 8 in. wide longitudinal connection. Panels for specimen 2 were 35 in. wide connected together with the 6 in. joint. The final dimension of the specimens after connecting the panels together was 76 in. long, 44 in. wide, and 8 in. deep. Spacing and size of the deck longitudinal bars were designed using AASHTO provisions. The resulting longitudinal reinforcement was as follows: No. 5 bars spaced at 9 in. top and bottom for specimen 1; No. 5 bars spaced at 9.5 in. top and bottom for specimen 2. Two longitudinal No. 5 bars run through the hooked bars in the closure pour connection as shown in the drawings.

The transverse reinforcement details were established by replicating the detailing for hooked bars connection from section NEDBT – 05 Beam Deck Details found in the guideline. Specification for the connection reinforcement (transverse bars) requires No. 4 bars to be placed along the entire width of the panels with 6 in. spacing. The transverse bars of two deck panels are staggered at a distance of 3 in. in the closure pour connection as seen in Figures 6-3b and 6-4b to avoid interference of bars between adjacent panels and to facilitate construction. These bars project 7 in. and 5 in. into the joint with an overlap length of 6 in. and 4 in. for specimen 1 and specimen 2, respectively, as depicted in Figures 6-1b and 6-2b. The inside bend diameter for No. 4 hooked bar is 3 in. ( $6d_b$ ). Clear cover for the reinforcing bars was designed to be 2.5 in. on the top and 1.5 in. on the bottom for both specimens. All reinforcement used in the specimens stratified ASTM 615 grade 60 reinforcement and contained epoxy coating.

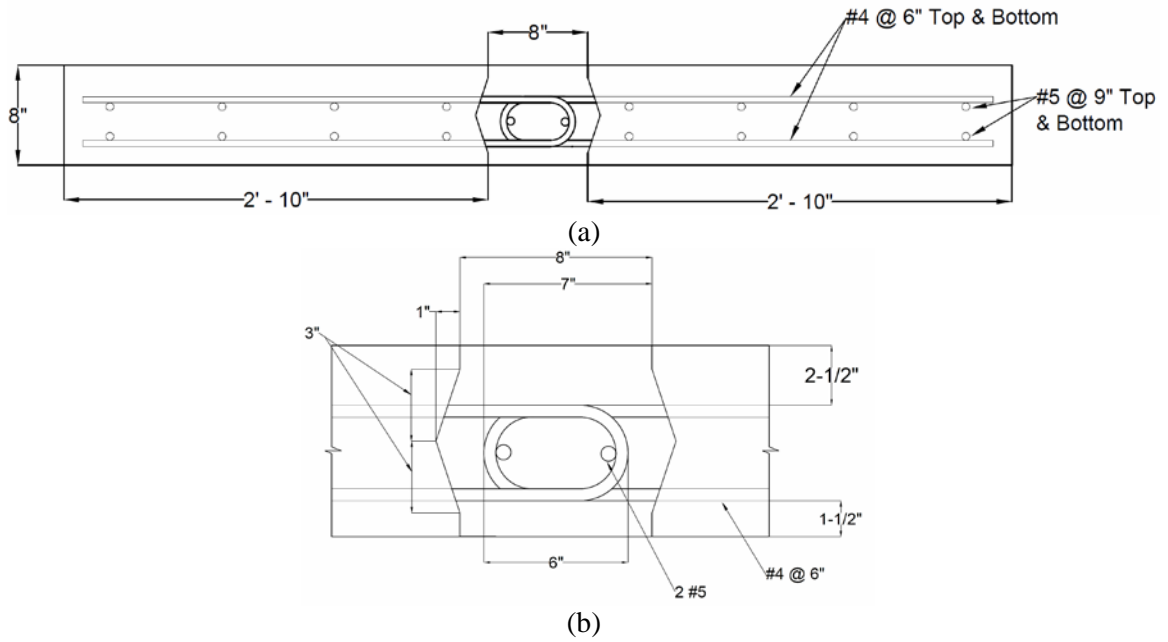

Figure 6-1: Details of Specimen 1: (a) Elevation View of Test Specimen; (b) Joint Detail

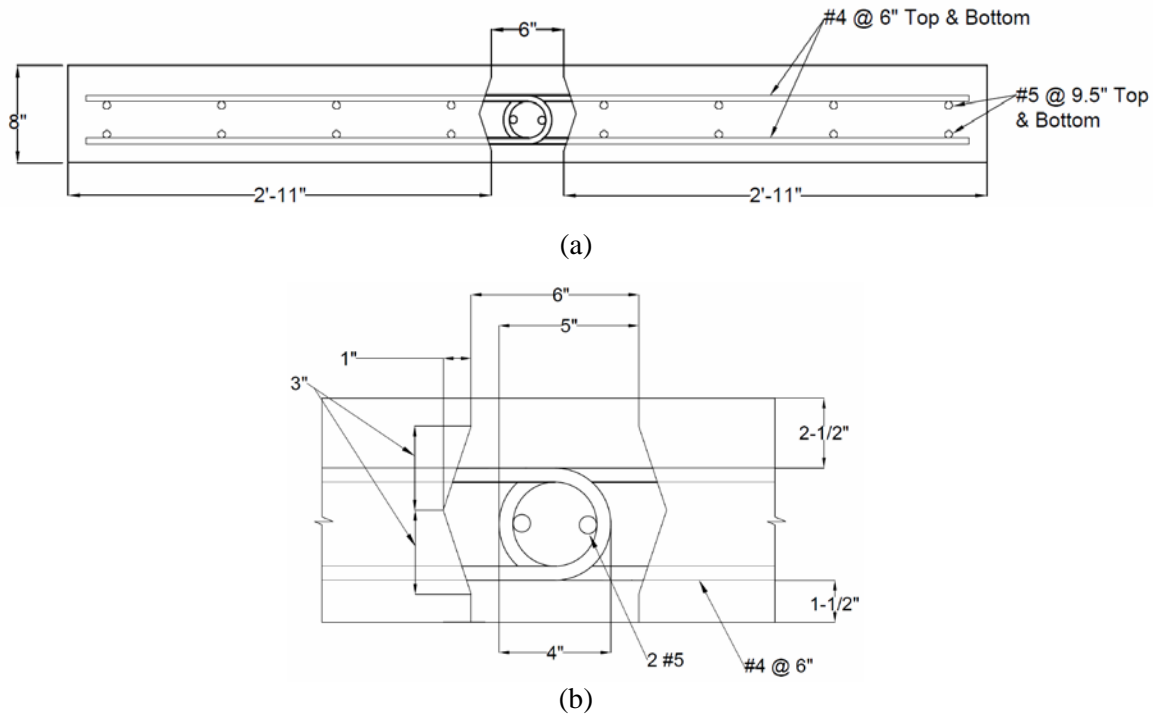

Figure 6-2: Details of Specimen 2: (a) Elevation View of Test Specimen; (b) Joint Detail

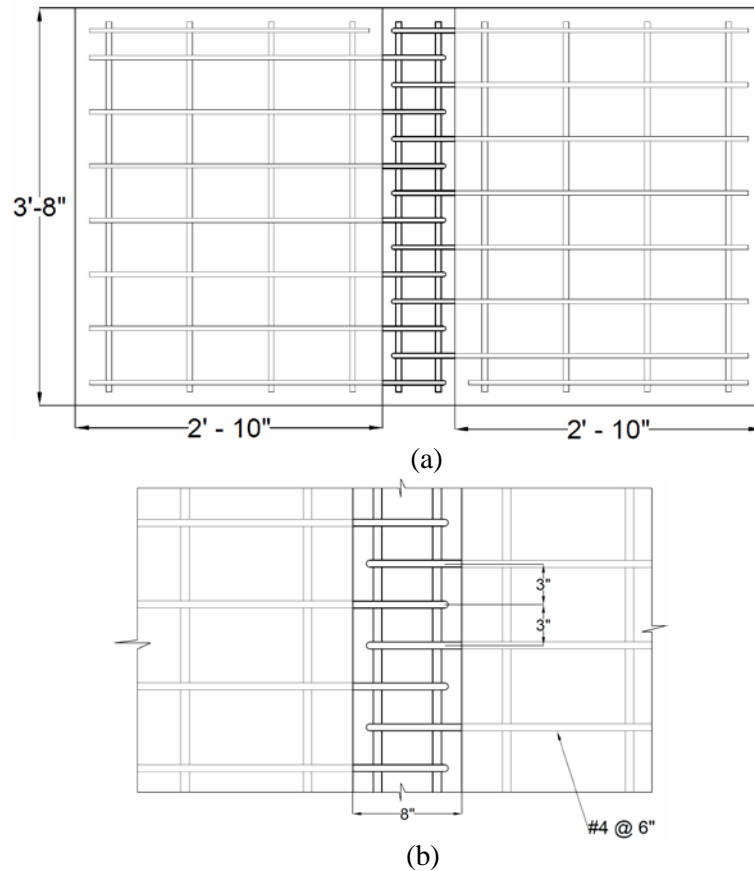

Figure 6-3: Specimen 1 Reinforcement: (a) Plan View of Test Specimen; (b) Joint Detail

### 6.3 Specimen Fabrication

Once the design was finalized, construction process for the specimens began. The specimens were constructed in two stages, with stage I involving building formwork and casting of the deck panels, followed by stage II which involved casting the closure pour connection. Test specimens were fabricated and tested in the Guinness Structural Engineering Laboratory at UMass Amherst.

#### 6.3.1 Panel Fabrication

In stage I, a total of four deck slabs were fabricated. The formwork for these slabs was built using standard lumber and plywood sheets. Lifting hooks were placed in the formwork prior to



pouring for specimen handling. During casting, a ready-mix concrete truck was ordered to perform the pour using normal-weight concrete with maximum aggregate size of  $\frac{3}{4}$  in. A target 28-day compressive strength of 4000 psi was specified and a slump of 4 in. to 6 in. was requested before concrete placement. As concrete was being poured in the panels, concrete cylinders were made for compressive strength. Once all the panels were poured, the concrete was allowed to cure in a controlled curing environment; specimens and concrete cylinders were cured under the same laboratory environment conditions. Burlap and plastic were used to cover exposed concrete surfaces during the curing process. Concrete was allowed to cure for 28 days. Photographs in figures 6-5(a)-(c) show the panels before and after casting.

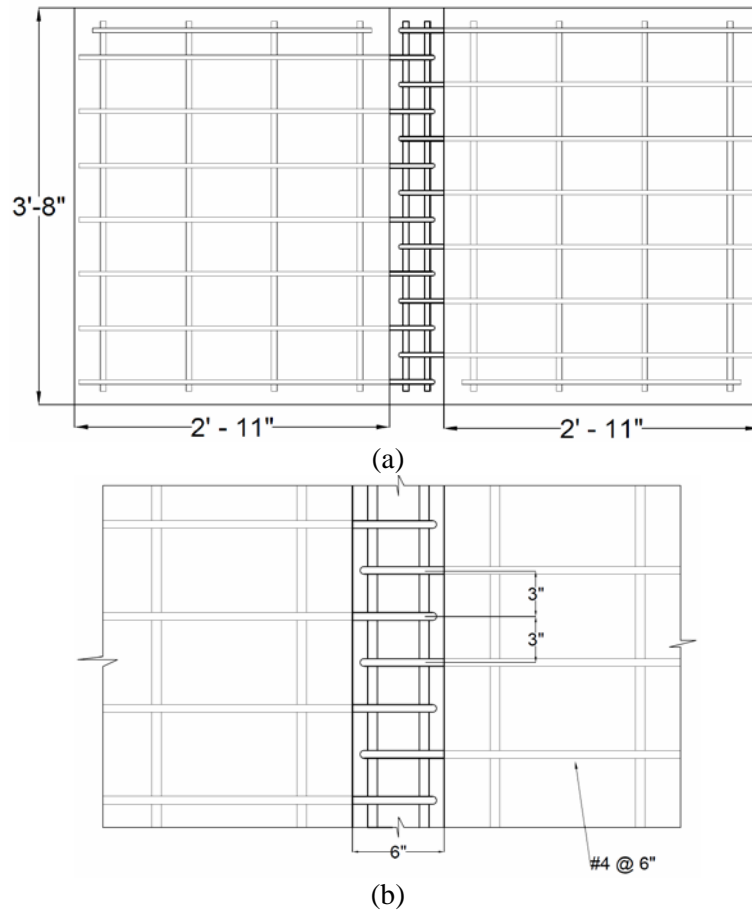

Figure 6-4: Details of Specimen 2: (a) Plan View of Test Specimen; (b) Joint Detail

### **6.3.1 Joint Construction**

In stage II, two panels of each specimen were positioned and properly oriented to satisfy the overlap lap length and spacing of the hooked bars in the closure pour connection. Plywood sheets were used to form the two free edges of the closure pour region and the joint was prepared for casting the high early-strength concrete mixture. The mix for the pour was done in accordance to the steps outlined in section 4.2 Mixing Procedure of this report, utilizing Mix 23. A STOW Model CM6 concrete mixer with a capacity of 6 cu ft. was used to perform the mix for the closure pour concrete. Prior to each mix, the recommended steps were taken to dampen the barrel of the mixer to reduce the amount of water absorbed by the residue adhered to the walls of the barrel.

During the mix, the aggregates were added first and mixed together until a homogeneous mixture was formed. The remaining constituents were added to the mixer in the order specified: cement, fly ash, pure mixing water, and mixing water containing the high-range water reducer chemical admixture. The constituents were mixed for 3 minutes, followed by a 3-minute rest period with the barrel opening covered with a layer of plastic, then a 2-minute final mixing period. After completing the mix, the concrete was poured into a wheelbarrow and cast into the joint between the two respective panels. Concrete cylinders were cast using the same mixture and cured under the same conditions as the closure pour. The mix produced a viscous concrete mixture without segregation. As concrete was being cast into the joint, a vibrator was not needed as the concrete did not require any vibrating to be consolidated within the joint. Photographs illustrating steps for the joint construction are shown in Figures 6-6(a)-(c).



(a)



(b)



(c)

Figure 6-5: Panel Fabrication: (a) Formwork and Reinforcement; (b) Casting; (c) Cured Panels

## 6.4 Test Set Up

All the specimens were tested under the loading and boundary condition shown in the schematic of the specimen test set up in Figure 6-7. The specimens were tested in a rigid loading frame composed of steel beams and columns. A 110 kip hydraulic actuator fitted with a load cell was used to apply the load. The actuator load was transferred to the specimens via two transverse rigid steel spreader beams. The load from the spreader beams was transferred to the concrete surface through two steel plates intended to act as point loads.



(a)



(b)



(c)

Figure 6-6: Joint Construction: (a) Panels Positioning (b) Concrete Casting (c) Finished Surface and Side View of Joint

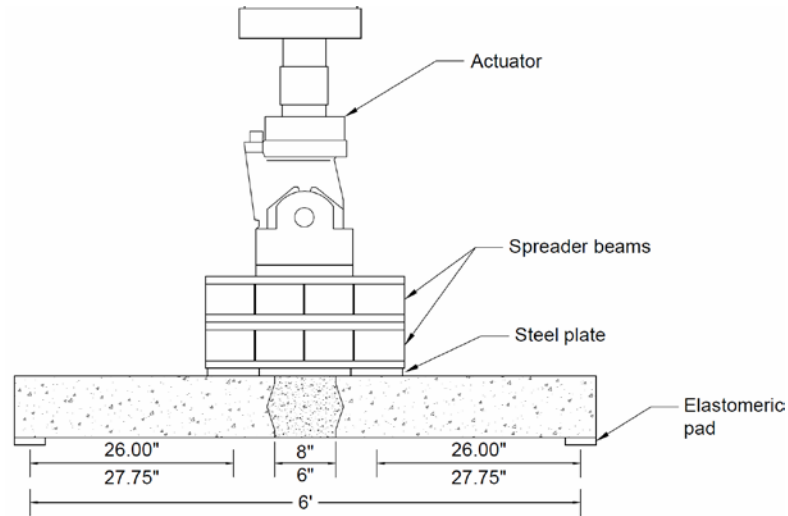

Figure 6-7: Schematic of the Specimen Test Set Up

The specimens were simply supported with a 6 ft. span. A 4 in. by 36 in. elastomeric bearing pad having a 1 in. thickness was placed between the slabs and the support steel beams to ensure boundary condition was achieved. The shear span for specimen 1 and specimen 2 was 26 in. and 27.75 in., respectively, as shown in the schematic drawing where the top and bottom dimensions are those corresponding to specimen 1 and 2, respectively. These dimensions for the

shear span considers the distance from the center of the bearing pad to the center of the steel plate. The joint zone was located in the center of the span and experienced a maximum constant moment and zero shear. A 4 in. linear potentiometer was positioned and centered on the top surface of the specimens to record deflection. A photograph of the final test set up including loading frame, specimen, actuator, and potentiometer is shown in Figure 6-8.

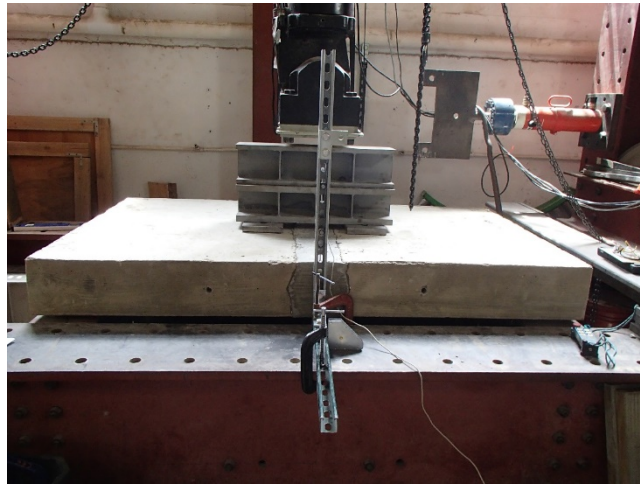

Figure 6-8: Test Set Up

## 6.5 Design Strength

Capacity of each specimen was determined two ways using nominal and measured material properties. Calculation for nominal material strength considers a compressive strength of 4000 psi and a yield strength of 60 ksi. In the calculation for measured material strength, the reinforcing steel was assumed to have an over strength of 20%, reaching a yield strength of 72 ksi. The average concrete compressive strength of the panels was 4570 psi. All the calculations were done using the force illustration shown in Figure 6-9. The shear and moment diagrams are also shown in the figure. The load from the actuator plus the self-weight of the spreader beams and steel plates was taken as two equal point loads positioned at the distance shown in the drawing with respective to each joint width. The shear ( $V$ ) is equal to the load divided by two ( $P/2$ ). The

maximum moment ( $M_{max}$ ) is determined by multiplying the point load ( $P/2$ ) by the shear span. Rotation point of the slab was assumed toward the inner face of the bearing pad, thus decreasing the shear span from 26 in. to 24.75 in. and 27.75 in. to 26.50 in. for specimen 1 and specimen 2, respectively. This behavior was verified during the test.

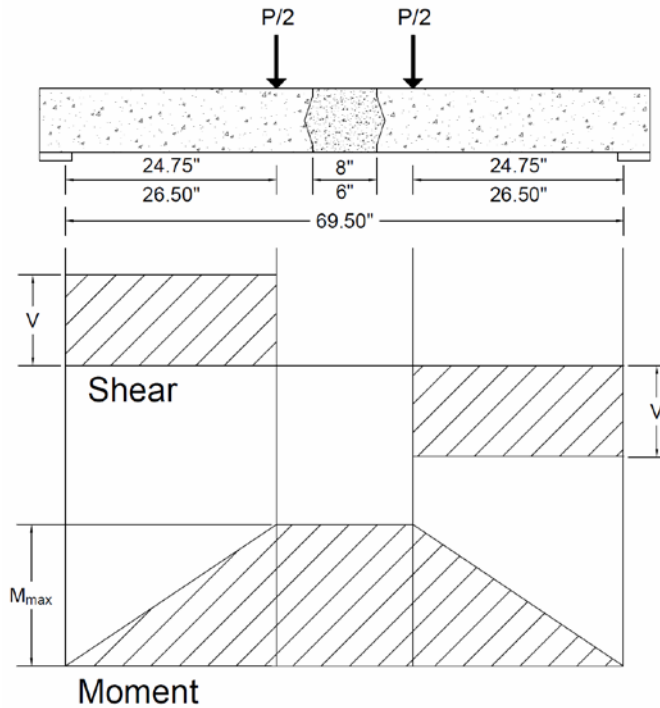

Figure 6-9: Test Specimen Force Application Diagram and Shear and Moment Diagrams

Calculation results for specimen capacity are presented in Table 6-1. The calculated capacity using nominal and measured material properties for specimen 1 was 52.0 kip and 62.2 kip, respectively. The calculated capacity using nominal and measured material properties for specimen 2 was 48.5 kip and 58.1 kip, respectively. The strength calculated using nominal material properties resulted in a more conservative load while the strength using measured material properties gave a higher load which is consistent with the load obtained from the experimental tests presented in the test results section.

Table 6-1: Summary of Specimen Capacity

Specimen	Nominal material strength		Measured material strength	
	M <sub>n</sub> (kip-ft)	P (kip)	M <sub>n</sub> (kip-ft)	P (kip)
1	53.6	52.0	64.2	62.2
2	53.6	48.5	64.2	58.1

## 6.6 Testing

Each specimen was tested a day after casting of the high early-strength concrete in the closure pour connection. Concrete cylinders were tested the day of testing to obtain the compressive strength of the closure pour concrete. The strength of the closure pour concrete obtained from the 4 in. by 8in. cylinder tests are presented in Table 6-2. Specimen 1 and specimen 2 were tested at approximately 26 hours after casting. The concrete in specimen 1 reached an average compressive strength of approximately 8400 psi in about 22 hours and 8640 psi in about 28 hours. The average 12-hour and 24-hour compressive strength for the concrete in specimen 2 was approximately 7395 psi and 8985 psi, respectively. The normal-strength concrete used in the deck panels had a measured compressive strength of about 4570 psi the day of testing.

Table 6-2: Compressive Strength Measured from Cylinder Tests

Cylinder	High early-strength concrete Specimen 1			High early-strength concrete Specimen 2		
	Compressive Strength (psi)	Force (lbs)	Time	Compressive Strength (psi)	Force (lbs)	Time
C1	8640	108610	9:50am	7280	91495	9:28pm
C2	8375	105250	10:10am	7510	94385	9:49pm
C3	8190	102900	10:30am	-	-	-
<b>Average</b>	<b>8402</b>	<b>105587</b>	<b>22 hrs</b>	<b>7395</b>	<b>92940</b>	<b>12 hrs</b>
C4	8550	107440	4:16pm	8755	110055	9:25am
C5	8520	107100	4:47pm	9090	114245	9:56am
C6	8860	111365	5:01pm	9110	114500	10:14am
<b>Average</b>	<b>8643</b>	<b>108635</b>	<b>28 hrs</b>	<b>8985</b>	<b>112933</b>	<b>24 hrs</b>



During the test, the specimens were loaded continuously at a load rate of approximately 4 kip/minute until failure. Failure was identified as the formation of large wide cracks and crushing of concrete. Each specimen was visually observed multiple times throughout the test to document any distress on the slabs. The specimens were inspected using visual crack techniques to monitor crack formation in the joint and panels.

## **6.7 Test Results**

Top view and front view of the specimens throughout the test are shown in Figures 6-10 through 6-16. In specimen 1, cracking was observed in the upper zone of the interface connection and within the top layer of the joint. Cracking in specimen 2 developed within the joint as depicted in Figure 6-10. Hairline flexural cracks formed in the deck panels at a distance of approximately 11.5 in. and 12 in. from the interface for specimen 1 and specimen 2, respectively. As loading progressed, the crack that developed within the joint of specimen 1 widened and extended into the panel as seen Figure 6-12. In specimen 2, another crack formed in the bottom layer of the joint and progressed towards the top layer of the joint. Near the peak load, concrete crushing occurred in the top surface, as expected of a flexure controlled failure mode. Concrete crushing was more pronounced in the concrete within the deck panels which were fabricated using normal-strength concrete. The joint concrete containing the high early-strength concrete did not suffer crushing as is evident in Figures 6-13 and 6-14.

Photographs of the specimens after failure can be seen in Figures 6-14 and 6-15. Crack formation in the connection interface in specimen 1 led to separation of the high early-strength concrete from the normal-strength concrete of the panels in the shear key connection as shown in Figure 6-15. The cracks that were initially observed only in the surface of the concrete in specimen 2 continued to propagate deeper into the joint until reaching one the transverse

reinforcing bar as loading progressed. These cracks intersected and caused a portion of the concrete to fall out. The end of the hooked bar can be observed in Figure 6-15. A similar crack pattern noticed in the front view of the specimens was observed in the rear view of the specimens as shown in Figure 6-16.

The failure mode of the two specimens is a typical flexural failure with concrete crushing at the top surface of the panels and cracks forming and widening from the bottom surface of the panels that are subjected to tension forces. Specimen 1 reached a maximum load of approximately 63.2 kip at a deflection of about 1.35 in. Specimen 2 registered a maximum load of approximately 58.3 kip corresponding to a deflection of about 1.26 in. Globally, specimen 1 and specimen 2 showed same general behavior as the deformation was concentrated in the closure pour connection. Locally, failure was different in terms crack formation in the joint.



Figure 6-10: Crack in the Joint: Specimen 1 (left); Specimen 2 (right)

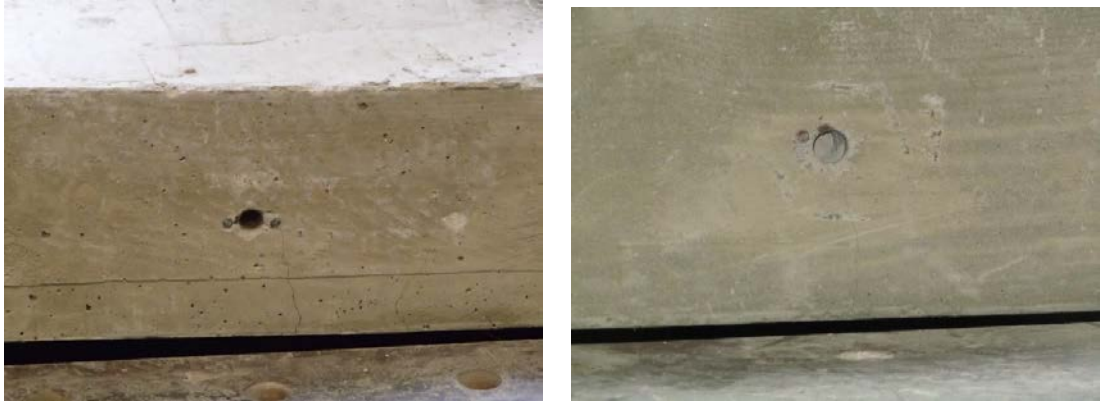

Figure 6-11: Hairline Flexural Cracks in the Panels: Specimen 1 (left); Specimen 2 (right)



Figure 6-12: Crack Propagation: Specimen 1 (left); Specimen 2 (right)



Figure 6-13: Concrete Crushing: Specimen 1 (left); Specimen 2 (right)



Figure 6-14: Top View after Failure: Specimen 1 (left); Specimen 2 (right)



Figure 6-15: Detail View (Front) of the Joint after Failure: Specimen 1 (left); Specimen 2 (right)



Figure 6-16: Detail View (Back) of the Joint after Failure: Specimen 1 (left); Specimen 2 (right)

The load-deflection relationship for each specimen is shown in Figures 6-17 and 6-18. It can be noticed that at a load of approximately 44 kip specimen 1 was unloaded. At this load, the

test was halted for quick adjustments in the elements used to transfer load. At this time there was not any major sign of distress noticed in the specimen. After the adjustment, loading was continued until failure of the specimen. There is a linear load deflection relationship in both plots from initial loading to a load of approximately 33 kips at a deflection of about 0.3 in. After this point, a change in stiffness can be observed from the curve. After unloading and reloading specimen 1, a linear relationship is once again noticed up to a load of about 45 kip as seen in Figure 6-17. Specimen 2 was loaded continuously without any interference of unloading and reloading as shown in Figure 6-18. Design load using nominal and measured material strengths are displayed with dashed lines in the plots to be compared with the peak load from the tests.

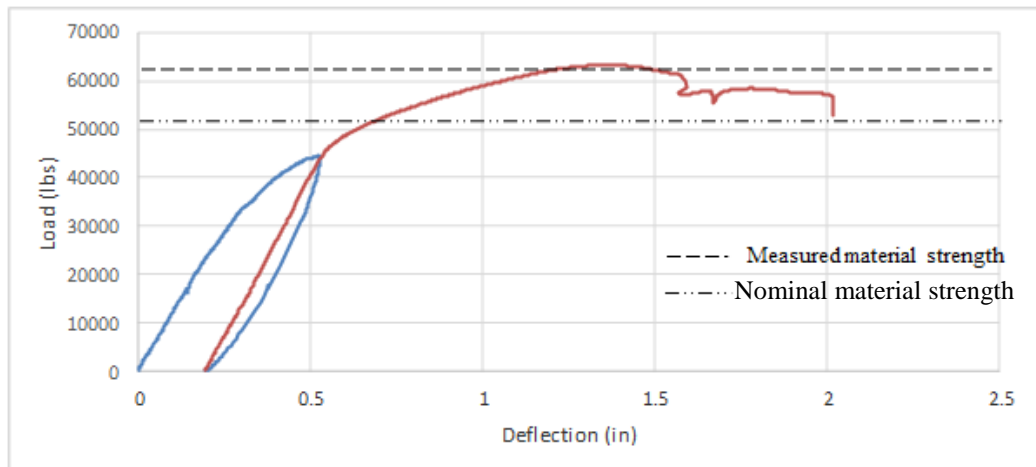

Figure 6-17: Load-Deflection Plot from Specimen 1 Test

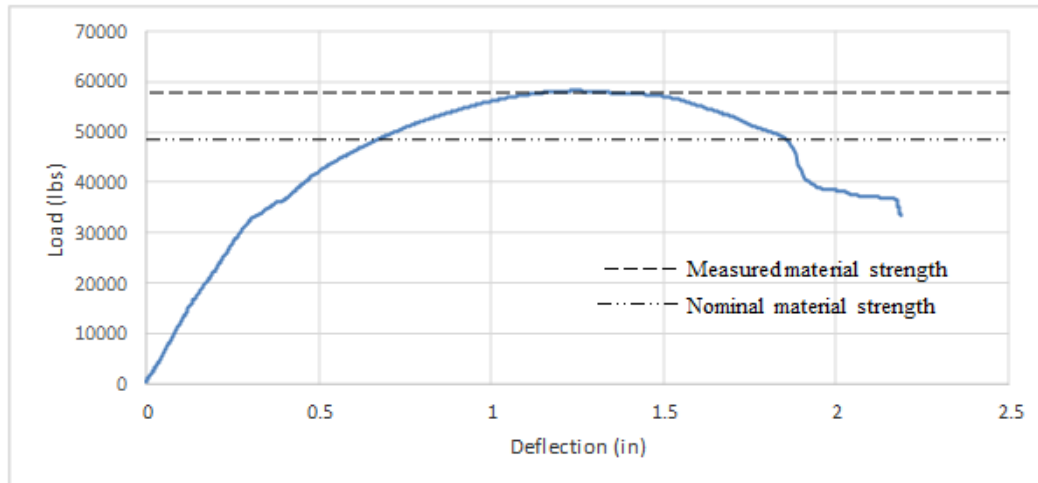

Figure 6-18: Load-Deflection Plot from Specimen 2 Test

Calculated capacity using nominal and measured material properties along with the failure load obtained from the experiment are presented in Table 6-3. For purpose of comparison, percent difference for calculated capacities and experimental failure load is also presented in the table. It can be seen that the design capacity using nominal material properties results in a lower capacity when compared with experimental results, underestimating the failure load by almost 19%. The design load using measured material properties is close to the failure load from the experiment, with a percent difference less than 2% for both specimens.

Table 6-3: Calculated Capacity and Experimental Failure Load Comparison

Specimen	Nominal material strength	Measured material strength	Experiment failure load	Nominal & Experiment % Diff	Measured & Experiment % Diff
1	52.0 kip	62.2 kip	63.2 kip	19.4 %	1.6 %
2	48.5 kip	58.1 kip	58.3 kip	18.4 %	0.3 %

## 7 CONCLUSIONS

Currently, most concrete mixture designs used for accelerated bridge construction closure pours are proprietary, making it difficult to specify these mixtures in federally funded projects. Therefore, the use of these materials in accelerated bridge construction projects is hindered. The goal of this research was to create a method to develop concrete mixtures that are designed using generic constituents and that satisfy performance requirements of accelerated bridge construction closure pours in New England, primarily high early strength and long-term durability. Two concrete mixtures were developed with a primary goal of reaching high-early strength while maintaining constructability. More specifically, a compressive strength equal to 4000 psi in 12 hours and a slump greater than or equal to 3 inches without segregation occurring. The secondary goal of the concrete mixtures was to be durable; therefore, measures were taken during the development of the concrete mixture to generate a mixture that also had durable properties.

To develop the concrete mixtures, various proportioning methods were studied. There were three methods considered: (1) building upon past experience by using state-of-practice concrete mixtures; (2) following ACI 211.4R Guidelines; and (3) targeting a mixture with maximum aggregate compaction. The first method used was the state-of-practice concrete mixtures, which were collected from DOTs and pre-casters throughout New England. For this method, the state-of-practice concrete mixtures were used as baseline designs. However, when state-of-practice concrete mixtures were replicated during this project, the strength and/or constructability goals of this project were not met. This was expected since the reported strength and/or constructability were also less than the goals of this project. Chemical admixture dosages

were altered in an attempt to achieve strength and constructability goals with the state-of-practice concrete mixtures, but it was not successful.

The second method considered for concrete proportioning was to follow the guidelines presented by ACI Committee 211, ACI 211.4R: *Guide for Selecting Proportions for High-Strength Concrete Using Portland Cement and Other Cementitious Materials*. The trial batch concrete mixtures developed using this method produced baseline results that were relatively close to acceptable strength and constructability limits. Through the use of chemical admixtures and slight alterations to the proportions, it appeared that this method would provide satisfactory results. However, this method was not chosen to be used as the primary proportioning method in this research project because proportioning is based on tables and equations without the exact constituent proportions necessarily being provided. The final method considered for concrete proportioning, maximum compaction of aggregates, also produced baseline results that had strength and constructability results that were within acceptable limits, and this method allowed for easier manipulation of the concrete mixture designs, given the knowledge of exact proportions.

The final method, maximum compaction of aggregate was developed using five parameters: aggregate gradation, coarse aggregate size, w/cm ratio, percent fly ash replacement and volume of paste to volume of voids ( $V_{\text{paste}}/V_{\text{voids}}$ ) ratio. Aggregate gradation was designed to create maximum compaction of aggregates, which was achieved using Fuller-Thompson curves. The coarse aggregate size, w/cm ratio, percent fly ash replacement and  $V_{\text{paste}}/V_{\text{voids}}$  ratio were modified throughout the development of the concrete mixtures. The initial values used were as follows: coarse aggregate size equal to 1/2 inch, w/cm equal to 0.26, 0% fly ash replacement and  $V_{\text{paste}}/V_{\text{voids}}$  equal to 1.75.



Using this method, an iterative process was followed to find two concrete mixtures which reached strength and constructability goals, while still showing promise for having durable properties. The target compressive strength of 4000 psi in 12 hours of curing was the primary strength requirement. The constructability goals were for the concrete mixture to have a slump greater than 3 inches without segregation occurring and a set time that allowed for the concrete to be placed using common construction techniques. It was found that concrete mixtures with a w/cm ratio equal to 0.26 had consistencies which were too stiff and thick to have acceptable constructability. Alternatively, concrete mixtures with w/cm ratios equal to 0.32 had consistencies that were too fluid, causing the coarse aggregates to segregate from the cement paste and strength to be compromised. A w/cm ratio equal to 0.29 yielded compressive strength and constructability results within acceptable limits.

It was also found that the majority of concrete mixtures which contained 3/8" coarse aggregate or a combination of 3/8" and 1/2" coarse aggregate had consistencies that were too stiff and thick. All concrete mixtures containing 3/8" coarse aggregate or a combination of 3/8" and 1/2" coarse aggregate in this research project had a w/cm ratio equal to 0.29, but had various fly ash replacement and  $V_{\text{paste}}/V_{\text{voids}}$  ratios. Although some of these concrete mixtures met strength requirements, the constructability was not acceptable, and, therefore, concrete mixtures containing 3/8" coarse aggregate were selected for further testing.

By changing the  $V_{\text{paste}}/V_{\text{voids}}$  ratio, the compressive strength was not changed significantly. However, the consistency of the concrete mixtures became too thick and stiff once the  $V_{\text{paste}}/V_{\text{voids}}$  ratio dropped to 1.25. Concrete mixtures that had  $V_{\text{paste}}/V_{\text{voids}}$  ratios equal to 1.75 and 1.50 with a w/cm ratio equal to 0.29 and 1/2" coarse aggregate had acceptable strength and constructability.

As expected, an increase in fly ash replacement percentage lowered compressive strength and increased the slump/spread measurement. A 15% fly ash replacement was found to provide enough strength while keeping the consistency fluid enough to be constructible.

Based on these results, it was concluded that the two concrete mixtures evaluated for durability with further testing were compromised of the following parameters: aggregate gradation providing maximum compaction, a w/cm ratio equal to 0.29, 1/2" coarse aggregate and a 15% fly ash replacement. One of the concrete mixtures had a  $V_{\text{paste}}/V_{\text{voids}}$  ratio equal to 1.75 and the other had a  $V_{\text{paste}}/V_{\text{voids}}$  ratio equal to 1.50.

No measures were taken to entrain air into the selected concrete mixtures. Although air entrainment is a positive measure that enhances freeze-thaw durability, it was decided to eliminate air entrainment because it would be detrimental to the rapid strength development that was sought in this project. The freeze-thaw durability testing conducted on four prisms revealed that acceptable durability could be achieved with these high-strength concrete mixtures because of their high density and reduction in pores. The four prisms went to 300 cycles of freezing-thawing temperatures without significant changes in frequency, length, or mass. Again, these results may be attributable to the high density mixes developed in this project and tight packing of aggregates. Further testing is recommended to verify the observations from freeze-thaw testing.

The bond strength between both of the selected concrete mixtures with No.4 and No.6 epoxy coated, grade-60 steel reinforcement was found to be adequate. When tested in tension, the bond strength between the test bar and both selected concrete mixtures was enough to have the bars reach their nominal yield strength. The failure mode of No.4 test bars in all pullout tests tested to failure was fracture of the reinforcing bar at the location of the connector. The fracture occurred at the section of the bar that was threaded to connect a Lenton Terminator that was used

to allow loading the bar in the testing apparatus. Localized concrete cracking also occurred in these tests. The failure mode of No.6 bar pullout tests was not determined due to the capacity limit of the test setup. However, the nominal yield strength of the test bar in all the specimens was reached and local concrete cracking and bar slip was also observed. There were no significant differences seen in the behavior of the different concrete mixtures in this test.

Both of the selected concrete mixtures developed in this research project performed well in terms plastic shrinkage and shrinkage cracking. Both of the selected concrete mixtures had a time to cracking that was typically greater than the time to cracking typically observed in normal concrete mixtures. There was some variability observed in the time to cracking of each of the concrete mixtures. There was greater variability observed with the concrete mixture that had a  $V_{\text{paste}}/V_{\text{voids}}$  ratio equal to 1.50 than the concrete mixture had a  $V_{\text{paste}}/V_{\text{voids}}$  ratio equal to 1.75. The highest shrinkage strain measured in the interior steel tube that is part of the test apparatus was equal to approximately  $-75 \mu\epsilon$  for each of the two high-early strength concrete mixtures selected as well as the normal concrete mixture used for comparison.

The crack widths of confined shrinkage specimens were monitored for two weeks after cracking. When the widths of the shrinkage cracks were compared, it was found that the widths of shrinkage cracks grew more and had larger final widths in specimens comprised of concrete with a greater paste content,  $V_{\text{paste}}/V_{\text{voids}}$  ratio equal to 1.75, than in those which had a lesser paste content,  $V_{\text{paste}}/V_{\text{voids}}$  ratio equal to 1.50. The specimens comprised of concrete with greater paste content had shrinkage cracks which reached a greater final crack width. Also, a general behavior was observed in both concrete mixtures correlating crack width with change in measured strain.

Larger final crack widths in a specimen corresponded to larger increase in strain measured in the steel tube at the time of cracking. This could be attributed to the higher strain

energy accumulated in the setup prior to cracking leading to larger crack width after release through concrete cracking.

The coarse and fine aggregates used for concrete mixtures in this research project did not give signs of causing deleterious expansion in the concrete when in combination with Type III ASTM cement and Class F fly ash. Aggregate reactivity was evaluated using a short alkali-silica reaction method (ASTM C1567) so the longer ASR standard (ASTM C1293) could be used to verify this result. The aggregates selected for this projects were not considered reactive.

In the large-scale experimental program, Mix 23 was used in a closure pour connection to study the material in conditions that are more representative of field applications. The specimens were designed and tested to simulate the longitudinal connection between two typical bridge decks using details for New England bulb tee girders. The results from these tests confirmed that the selected mixture in closure pour connection is capable of developing high strength and ensuring adequate transfer of forces between structural components in one day. The connections were able to surpass the nominal flexural strength. Using measured material properties, common design equations were adequate to calculate the strength of the connections measured in the laboratory. The results of the tests could be extended to other applications including other pretensioned fully decked beams or full-depth precast panels. Since the full-scale tests conducted in this research are limited, further testing at the full-scale is recommended to validate the results found in this research.

## **7.1 Recommendations for Concrete Specification**

Based on the results seen while developing these concrete mixtures as well as the literature review and the compiled survey results, a concrete mixture design specification was

written for concrete mixtures used for accelerated bridge construction closure pour applications. The specification is provided in APPENDIX D. Based on this research it was concluded that reaching a compressive strength of 4000 psi in 12 hours is difficult to achieve while maintaining adequate constructability and while using non-proprietary materials. A compressive strength of 3500 psi after 12 hours of curing at 80°F was attainable while maintaining constructability and meeting durability goals. Therefore, if a compressive strength equal to 4000 psi is required, then the concrete should be given 14 hours to cure, or the concrete should be cured at a higher temperature.

It is recommended for the concrete to have a slump value greater than or equal to 4 inches and a spread value that is less than 30 inches. These parameters are provided to ensure that the concrete mixture will have an acceptable consistency. It was found that concrete mixtures with a slump less than 4 inches were very thick and stiff, making it difficult to cast into molds, and concrete mixtures with a spread greater 30 inches were at risk for segregation, and therefore, reduced compressive strength.

The initial set time, as defined by ASTM C403, is recommended to lie between 3 and 6 hours after casting for these concrete mixtures. It was observed that an initial set time of 3 hours was attainable with these types of concrete mixtures. By having an initial set time of at least 3 hours, sufficient workability time is likely provided for the concrete to be cast in the field. If the initial set time were longer than 6 hours, it was an indication that cement hydration reaction was not occurring at a rate that was fast enough to achieve the required strength.

Bond strength between the concrete mixture and steel reinforcement used in accelerated bridge construction closure pour concrete did not seem to be negatively affected. Bond strength was determined using ASTM A944 (bar pull-out using beam end-specimens). The maximum load

reached in the tests conducted for this research was at least equal to the nominal yield strength of the steel reinforcement tested. Bond strength tests on large-scale components in flexure could be conducted to verify the bond behavior in a bending application.

The recommendation given in the specification for expansion limits on alkali-silica test specimens is the same as the recommendation provided in ASTM C1567, which is less than 0.10% expansion. Each very aggregate source should be tested for a potential deleterious alkali-silica reaction before it is used in a concrete mixture in the field.

The final recommendation given for the concrete mixtures used for closure pours in accelerated bridge construction projects are limits on confined shrinkage measured using the AASHTO PP 34-99 ring test. It is recommended that any concrete mixture developed does not crack under confined shrinkage any sooner than 14 days after casting. Since great variability can occur with these tests, at least 3 tests should be run to better understand the behavior of the concrete mixtures.

It is also recommended that chloride permeability be tested on each concrete mixture to be used for this application. The chloride permeability test was not performed as part of this project. Four specimens for freeze-thaw test were fabricated and tested at MassDOT facilities. Given the limited number of specimens tested under a freeze-thaw protocol, the results should be viewed with caution and further testing in this area is also recommended.

Finally, it should also be noted that a significant amount of variability was seen with the properties of concrete mixtures tested during this research project. The greatest variability was observed with the consistency of the concrete mixtures, which many times led to variations in compressive strength. This variability was likely caused by the small mixture volumes that were

used. As with any mixture design, trial batches are required at the supplier to ensure expected performance.

## REFERENCES

- AASHTO. (2012). *AASHTO LRFD Bridge Design Specifications*
- ACI Committee 232. (2003). *Use of fly ash in concrete Reported by ACI Committee 232. NCHRP Synthesis of Highway Practice.*
- ACI Committee E-701. (2013). *Cementitious Materials for Concrete.*
- ACI Committee 211. (2008). *Guide for Selecting Proportions for High-Strength Concrete Using Portland Cement and Other Cementitious Materials.*
- ACI Committee E-701. (1999). *Aggregates for Concrete.*
- ACI Committee E-701. (2003). *Chemical Admixtures for Concrete.*
- Akkaya, Y., Ouyang, C., and Shah, S. P. (2007). "Effect of supplementary cementitious materials on shrinkage and crack development in concrete." *Cement and Concrete Composites*, 29, 117–123.
- Al-manaseer, A. A., Aquino, E. B., and Kumbargi, H. (2000). "Properties of Concrete Containing Ultimax Rapid-Setting Hydraulic Cement." *ACI Materials Journal*, (96), 529–535.
- Balaguru, P. N., and Bhatt, D. (2001). "Rapid Hardening Concrete." Rutgers, The State University Center for Advanced Infrastructure and Technology, NJDOT, U.S. DOT FHA.
- Beerman, B. (2016). "U.S. DOT Federal Highway Administration." *Accelerating Innovation: Prefabricated Bridge Elements and Systems.*
- Brooks, J. J., Johari, M. A. M., and Mazloom, M. (2000). "Effect of admixtures on the setting times of high-strength concrete." *Cement & Concrete Composites*, 22, 293–301.
- Brown, J. H. (1980). *Effect of Two Different Pulverized Fuel Ashes Upon the Workability and Strength of Concrete.* Wexham Springs, UK.
- Byard, B. E., and Ries, J. (2011). "Optimizing the Sustainability of Concrete Through Internal Curing.pdf." American Concrete Institute Special Publication.
- Folliard, K. J., and Berke, N. S. (1997). "Properties of High Performance Concrete Containing Shrinkage-Reducing Admixture." *Cement and Concrete Research*, 27, No 9, 1357–1364.
- Freyne, S. F., Russell, B. W., Bush, T. D., and Hale, W. M. (2004). "Comparing Different Cements in High-Performance Concrete." *ACI Materials Journal*, (November-December), 435–441.
- Han, V., Ros, S., and Shima, H. (2013). "Effects of sand content, superplasticizer dosage, and mixing time on compressive strength of mortar." *ACI Materials Journal*, 110(1), 23–31.
- Heat Authority. (2015). "Heat Authority."
- Hover, K., and Stokes, T. (1995). "Making 'Cents' out of the Water-Cement Ratio." *Concrete International*, May, 52–54.



- Koehler, E. P. (2014). "Rethinking Mixture Proportioning: Aggregate Suspension Method." American Concrete Institute 2013 Convention, Minneapolis, Minnesota.
- Koehler, E. P., and Fowler, D. W. (2006). *ICAR Mixture Proportioning Procedure for Self-Consolidating Concrete: 108-1. Education*.
- Koehler, E. P., and Fowler, D. W. (2007). "Development of Self-Consolidating Concrete for Prestressed Bridge Beams." 1–16.
- Kosmatka, S. H., Kerkhoff, B., and Panarese, W. C. (2003). "Design and Control of Concrete Mixtures." Portland Cement Association.
- Kurtz, M. A., and Constantiner, D. (2004). "Resistance to Freezing and Thawing Cycles and Scaling Resistance of Very High Early Strength Concrete." *Cement, Concrete, and Aggregates*, 26(2), 160–164.
- Lane, R. O. (1983). "Effects of Fly Ash on Freshly Mixed Concrete." *Concrete International*, 5(10), 50–52.
- Mindess, S., and Young, J. F. (1981). *Concrete*. (K. Winkler, ed.), Prentice-Hall, Inc.
- Najm, H., and Balaguru, P. (2005). "Rapid-Hardening Concrete Mixes." *Journal of Materials in Civil Engineering, ASCE*, (March/April), 198–206.
- PCI Northeast. (2016). *Northeast Deck Bulb Tee Beam Details*. PCI Northeast Deck Bulb Tee Guidelines (NEDBT)
- Riding, K. a., Poole, J. L., Schindler, A. K., Juenger, M. C. G., and Folliard, K. J. (2008). "Quantification of effects of fly ash type on concrete early-age cracking." *ACI Materials Journal*, 105(2), 149–155.
- Russell, H., and Graybeal, B. A. (2013). *Ultra-High Performance Concrete : A State-of-the-Art Report for the Bridge Community*. U.S. Department of Transportation Federal Highway Administration, McLean, VA.
- Schindler, A. K. (2004). "Effect of temperature on hydration of cementitious materials." *ACI Materials Journal*, 101(1), 72–81.
- See, H. T., Attiogbe, E. K., and Miltenberger, M. A. (2003). "Shrinkage Cracking Characteristics of Concrete Using Ring Specimens." *ACI Materials Journal*, (May-June), 239–245.
- Shane, J. D. (Northwestern U., Mason, T. O. (Northwestern U., and Jennings, H. M. (Northwestern U. (2000). "Effect of Interfacial Transition Zone on the Conductivity of Portland Cement Mortars." *Journal of the American Ceramic Society*.
- Taylor, P., Yurddakul, E., Wang, X., and Wang, X. (2015). *An Innovative Approach To Proportioning Concrete Mixtures*.
- Transportation Research Board. (2013). *Durability of Concrete. Transportation Research Circular E-C171*.
- Xie, W., Yuan, D., and Li, S. (2012). "Influence of Aggregate Gradation of Coarse Aggregates on Concrete Strength." *Applied Mechanics and Materials*, Trans Tech Publications, Switzerland, 147–149.

Young, J. F., Mindess, S., Gray, R. J., and Bentur, A. (1998). "The Science and Technology of Civil Engineering Materials." W. Stenquist and M. Horton, eds., Prentice-Hall, Inc.

Zhuang, J. (2009). "Evaluation of Concrete Mix Designs to Mitigate Early-Age Shrinkage Cracking in Bridge Decks." *Dissertation*, Washington State University.

## APPENDIX A

### AGGREGATE PROPERTIES

#### Gradation Curves

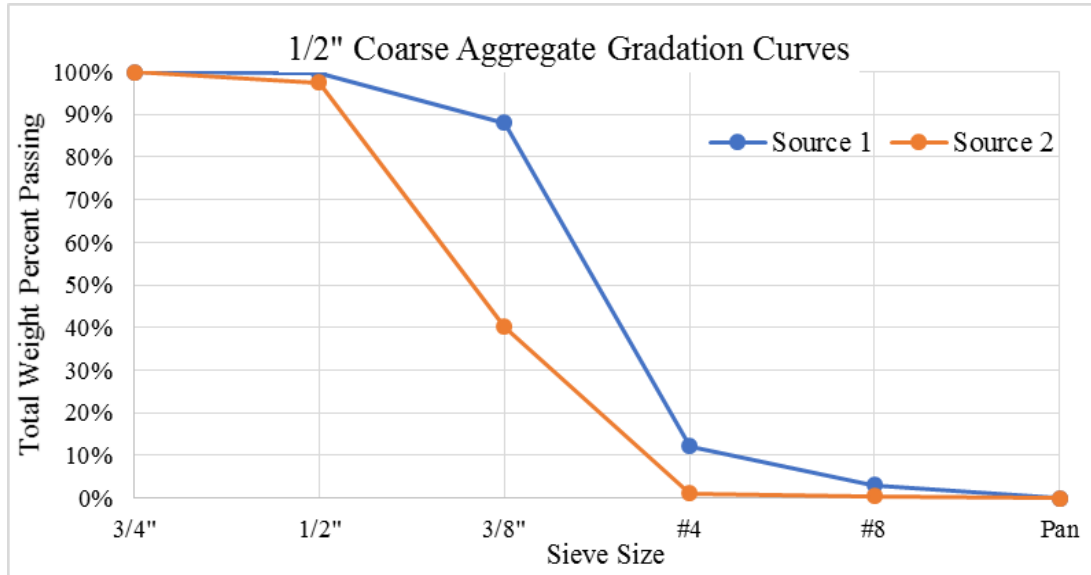

Figure A-0-1: 1/2" Aggregate Gradation Curves of Source 1 and Source 2 Aggregates

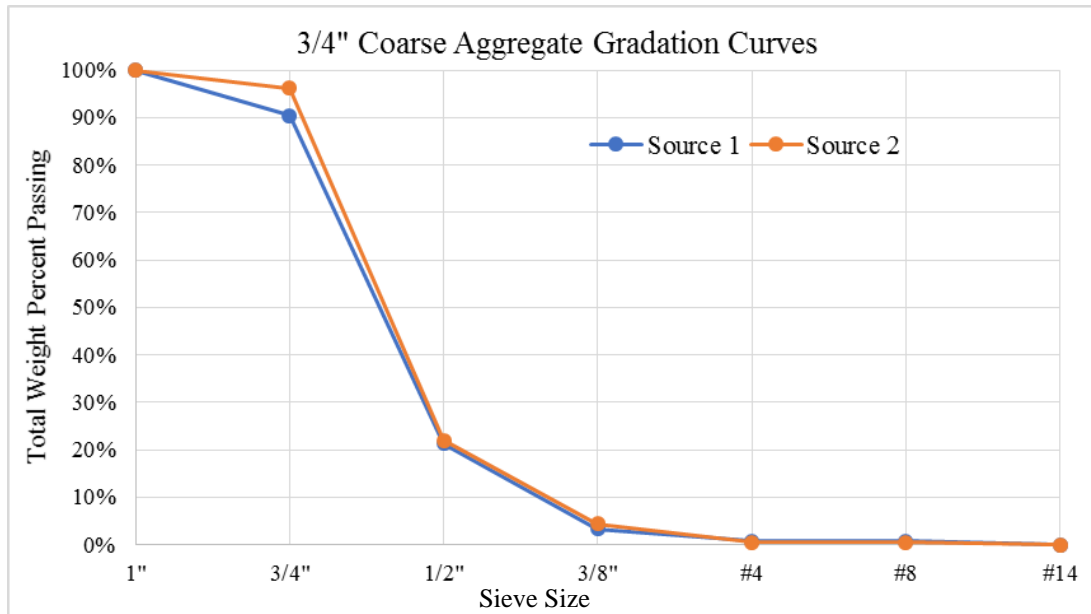

Figure A-0-2: 3/4" Aggregate Gradation Curves of Source 1 and Source 2 Aggregates

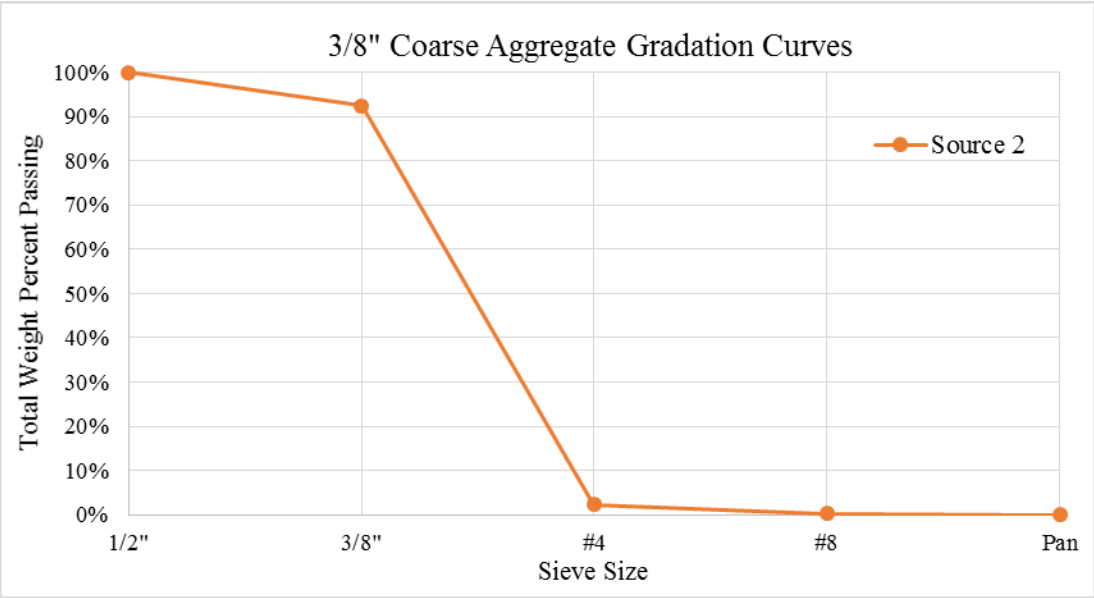

Figure A-0-3: 3/8" Aggregate Gradation Curves of Source 2 Aggregates

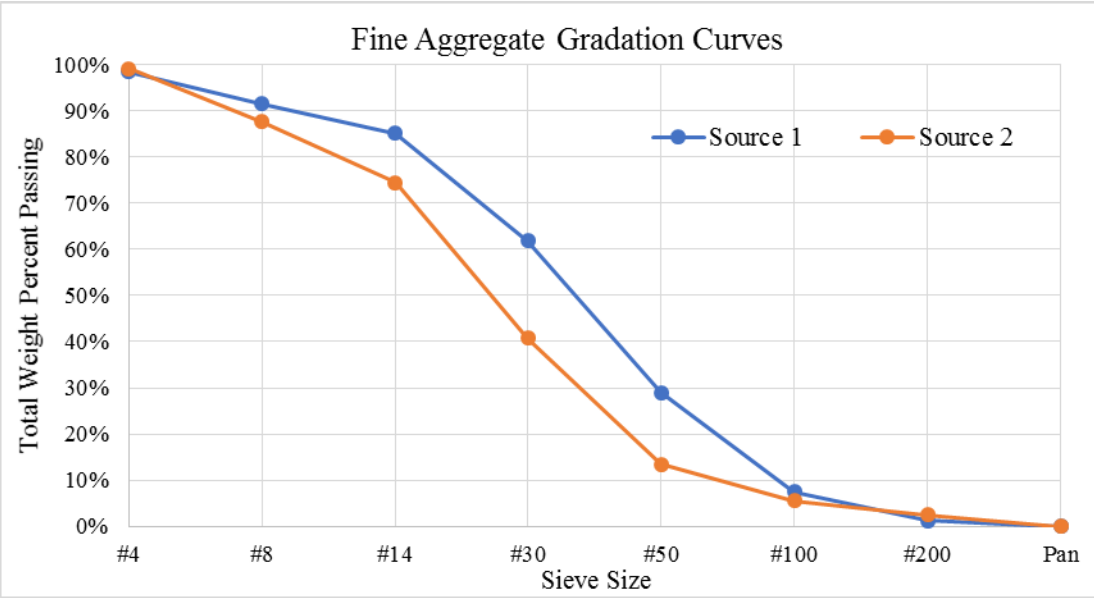

Figure A-0-4: Fine Aggregate Gradation Curves of Source 1 and Source 2 Aggregates

**Additional Aggregate Properties**

Table A-1: Summary of Source 1 and Source 2 Coarse and Fine Aggregate Properties

		Bulk Density (lb/ft <sup>3</sup> )		% Voids	Relative Density (Specific Gravity)		Apparent Relative Density (Apparent Specific Gravity)	Density (lb/ft <sup>3</sup> )		Apparent Density (lb/ft <sup>3</sup> )	Absorption Capacity
		Rodded	Loose		Oven Dried	Saturated Surface-Dry		Oven Dried	Saturated Surface-Dry		
Source 1	Fine Aggregate	102.3	96.4	40.3%	2.75	2.81	2.91	171	175	181	1.97%
	1/2" Coarse Aggregate	95.5	89.8	40.2%	2.56	2.62	2.71	160	163	169	2.16%
	3/4" Coarse Aggregate	97.3	93.5	40.6%	2.62	2.66	2.72	163	166	170	1.34%
Source 2	Fine Aggregate	75.6	70.8	54.6%	2.67	2.70	2.76	166	168	172	1.22%
	3/8" Coarse Aggregate	64.6	60.4	64.1%	2.89	2.93	3.00	180	182	187	1.34%
	1/2" Coarse Aggregate	64.0	61.6	64.4%	2.88	2.92	2.99	180	182	186	1.24%
	3/4" Coarse Aggregate	99.1	86.8	43.6%	2.82	2.86	2.92	176	178	182	1.27%

## APPENDIX B

### TRIAL BATCH CONCRETE MIXTURE DESIGNS

Table B-1: Trial Batch Concrete Mixture Design Quantities per Cubic Yard of Concrete  
(MIX 1 – MIX 4)

Component	Material	Maximum Aggregate Compaction Trial Batches			
		MIX 1	MIX 2	MIX 3	MIX 4
Coarse Aggregate (lb) <sup>1</sup>	1/2" Crushed Stone	1255	1252	1251	1251
	3/8" Crushed Stone	–	–	–	–
Fine Aggregate (lb) <sup>1</sup>	Concrete Sand	1045	1043	1043	1042
Cement (lb)	Type III Portland Cement	1501	1251	1170	1090
Fly Ash (lb)	Class F	–	221	293	363
	Class C	–	–	–	–
Water (lb) <sup>2</sup>	N/A	382	374	372	370
Chemical Admixtures (fl. oz.)	Accelerator	–	–	–	–
	Superplasticizer	216	180	168	157
1 - Weight of Aggregate Corresponds to Oven-Dried Weights					
2 - Weight of Water Excludes Water Absorbed by Aggregates and was Adjusted for Water Content of Chemical Admixtures					

Table B-2: Trial Batch Concrete Mixture Design Quantities per Cubic Yard of Concrete Cont.  
(MIX 5 – MIX 7)

Component	Material	Maximum Aggregate Compaction Trial Batches			
		MIX 5	MIX 6	MIX 6-HD	MIX 7
Coarse Aggregate (lb) <sup>1</sup>	1/2" Crushed Stone	1254	1252	1252	1251
	3/8" Crushed Stone	–	–	–	–
Fine Aggregate (lb) <sup>1</sup>	Concrete Sand	1045	1043	1043	1043
Cement (lb)	Type III Portland Cement	1426	1190	1190	1113
Fly Ash (lb)	Class F	–	210	210	278
	Class C	–	–	–	–
Water (lb) <sup>2</sup>	N/A	406	398	396	396
Chemical Admixtures (fl. oz.)	Accelerator	–	–	–	–
	Superplasticizer	205	171	224	160
1 - Weight of Aggregate Corresponds to Oven-Dried Weights					
2 - Weight of Water Excludes Water Absorbed by Aggregates and was Adjusted for Water Content of Chemical Admixtures					

Table B-3: Trial Batch Concrete Mixture Design Quantities per Cubic Yard of Concrete Cont.  
(MIX 7A – MIX 9)

Component	Material	Maximum Aggregate Compaction Trial Batches			
		MIX 7-A	MIX 7-C	MIX 8	MIX 9
Coarse Aggregate (lb) <sup>1</sup>	1/2" Crushed Stone	1266	1251	1251	1254
	3/8" Crushed Stone	–	–	–	–
Fine Aggregate (lb) <sup>1</sup>	Concrete Sand	1055	1043	1042	1045
Cement (lb)	Type III Portland Cement	1126	1113	1037	1359
Fly Ash (lb)	Class F	282	–	346	–
	Class C	–	278	–	–
Water (lb) <sup>2</sup>	N/A	381	396	393	427
Chemical Admixtures (fl. oz.)	Accelerator	563	–	–	–
	Superplasticizer	162	160	149	196
1 - Weight of Aggregate Corresponds to Oven-Dried Weights					
2 - Weight of Water Excludes Water Absorbed by Aggregates and was Adjusted for Water Content of Chemical Admixtures					



Table B-4: Trial Batch Concrete Mixture Design Quantities per Cubic Yard of Concrete Cont.  
(MIX 10 – MIX 12)

Component	Material	Maximum Aggregate Compaction Trial Batches			
		MIX 10	MIX 11	MIX 11-C	MIX 12
Coarse Aggregate (lb) <sup>1</sup>	1/2" Crushed Stone	1252	1251	1251	1250
	3/8" Crushed Stone	–	–	–	–
Fine Aggregate (lb) <sup>1</sup>	Concrete Sand	1043	1043	1043	1042
Cement (lb)	Type III Portland Cement	1135	1062	1062	990
Fly Ash (lb)	Class F	200	265	–	330
	Class C	–	–	265	–
Water (lb) <sup>2</sup>	N/A	420	417	417	415
Chemical Admixtures (fl. oz.)	Accelerator	–	–	–	–
	Superplasticizer	163	153	153	142
1 - Weight of Aggregate Corresponds to Oven-Dried Weights					
2 - Weight of Water Excludes Water Absorbed by Aggregates and was Adjusted for Water Content of Chemical Admixtures					

Table B-5: Trial Batch Concrete Mixture Design Quantities per Cubic Yard of Concrete Cont.  
(MIX 13 – MIX 15)

Component	Material	Maximum Aggregate Compaction Trial Batches			
		MIX 13	MIX 14	MIX 14-A	MIX 15
Coarse Aggregate (lb) <sup>1</sup>	1/2" Crushed Stone	–	–	–	1350
	3/8" Crushed Stone	1149	1149	1162	–
Fine Aggregate (lb) <sup>1</sup>	Concrete Sand	1149	1149	1162	1125
Cement (lb)	Type III Portland Cement	1108	1032	1044	1100
Fly Ash (lb)	Class F	277	344	348	194
	Class C	–	–	–	–
Water (lb) <sup>2</sup>	N/A	394	391	376	368
Chemical Admixtures (fl. oz.)	Accelerator	–	–	557	–
	Superplasticizer	159	148	150	158
1 - Weight of Aggregate Correspond to Oven-Dried Weights					
2 - Weight of Water Excludes Water Absorbed by Aggregates and was Adjusted for Water Content of Chemical Admixtures					

Table B-6: Trial Batch Concrete Mixture Design Quantities per Cubic Yard of Concrete Cont.  
(MIX 15-HD – MIX 18)

Component	Material	Maximum Aggregate Compaction Trial Batches			
		MIX 15-HD	MIX 16	MIX 17	MIX 18
Coarse Aggregate (lb) <sup>1</sup>	1/2" Crushed Stone	1350	481	1465	522
	3/8" Crushed Stone	–	535	–	580
Fine Aggregate (lb) <sup>1</sup>	Concrete Sand	1125	1451	1221	1574
Cement (lb)	Type III Portland Cement	1100	1093	995	988
Fly Ash (lb)	Class F	194	193	176	174
	Class C	–	–	–	–
Water (lb) <sup>2</sup>	N/A	366	366	333	330
Chemical Admixtures (fl. oz.)	Accelerator	–	–	–	–
	Superplasticizer	207	157	143	142
1 - Weight of Aggregate Correspond to Oven-Dried Weights					
2 - Weight of Water Excludes Water Absorbed by Aggregates and was Adjusted for Water Content of Chemical Admixtures					

## APPENDIX C

### CONCRETE MIXTURE TEST RESULTS

Table C-1: Results from Compressive Strength Tests of Concrete Mixtures

Compressive Strength (psi) of Concrete Mixtures <sup>1</sup>							
Concrete Mixture	Batch	Curing Time					
		12 Hours	18 Hours	24 Hours	7 Day	14 Day	28 Day
MIX 1	a	5860	-	7500	9120	-	10540
MIX 2	a	5198	-	7060	9420	-	11270
MIX 3	a	4320	-	6710	7610	-	9660
MIX 4	a	4750	-	6210	7370	-	7940
MIX 5	a	4390	-	7600	-	-	10390
MIX 6	a	4320	-	6290	-	-	9400
	b	2610	-	6540	-	-	-
	c	4220	-	5200	-	-	-
	d	4380	-	5400	-	-	-
MIX 6-HD	a	4280	-	5940	-	-	-
	b	3500	-	5870	-	-	-
	c	3870	-	5710	7680	-	10560
	d	3570	-	5660	-	-	-
	e	3970	-	5340	-	-	-
	f	3840	-	5470	-	-	-
MIX 6-HD-H		5140	-	6160	-	-	-
MIX 7	a	2070	-	5980	8100	-	9980
MIX 7-C	a	2860	-	-	6500	-	9760
MIX 7-A	a	2900	-	-	8650	-	10640
MIX 8	a	1050	-	5610	-	-	9320
MIX 9	a <sup>2</sup>	1440	3830	5300	-	-	6920
	b	4640	5210	5700	-	-	7530
	c	4880	6760	-	8770	-	9875
MIX 10	a	2890	-	5990	-	-	9630

1 – Followed ASTM Standard C39 Using 4” by 8” Cylinders  
2 - Batch was hand mixed; uniform mixing was not attained

Table C-2: Results from Compressive Strength Tests of Concrete Mixtures (Cont.)

Compressive Strength (psi) of Concrete Mixtures <sup>1</sup>							
Concrete Mixture	Batch	Curing Time					
		12 Hours	18 Hours	24 Hours	7 Day	14 Day	28 Day
MIX 11	a	2680	-	5830	7880	-	9580
MIX 11-C	a	1900	-	5780	8380	-	10070
MIX 12	a	940	-	4970	-	-	9160
MIX 13	a	4490	-	5860	8340	-	9740
MIX 14	a	3910	-	5880	8560	-	10940
	b	3120	-	4560	-	-	-
	c	3480	-	4800	-	-	-
	d	2380	-	4450	-	-	-
	e	2360	-	4700	-	-	-
	f	1210	-	3820	-	-	-
MIX 14-A	a	1870	-	5770	-	10070	11770
	b	3480	-	4040	8900	-	-
	c	2610	-	5090	-	-	-
MIX 15	a	4130	-	5330	7480	-	-
	b	3690	-	4870	6510	-	-
	c	3600	-	4920	-	-	-
MIX 15-HD	a	3970	-	5620	-	-	-
	b	3700	-	5360	-	-	-
	c	3930	-	5350	7500	-	10300
	d	3670	-	5140	-	-	-
	e <sup>3</sup>	1800	-	5090	-	-	-
MIX 15-HD-H	a	5200	-	6160	-	-	-
MIX 16	a	3420	-	5010	-	-	-
	b	3830	-	5080	-	-	-
MIX 17	a	3880	-	4900	7090	-	-
MIX 18	a	3690	-	5080	-	-	-
	b	3250	-	4790	-	-	-

1 - Followed ASTM Standard C39 Using 4" by 8" Cylinders  
3 - The machine mixer was much warmer than typical; caused segregation to occur

Table C-3: Air Content Measured in Concrete Mixtures

Concrete Mixture	Air Content (%) <sup>1</sup>
6(A)	2.4
6(B)	3.5
6(C)	3.3
14(A)	3.5
14(A)	3.5
15(A)	2.4
15(B)	1.1
15(C)	1.8
16(A)	2.7
16(B)	2.1
17(A)	2.4
17(B)	2.3
18(A)	2.7
18(B)	2.5
6-HD(A)	1.2
6-HD(B)	1.9
6-HD(C)	1.4
6-HD(D)	2.3
6-HD(E)	1.7
15-HD(A)	2.0
15-HD(B)	2.2
15-HD(C)	1.4
15-HD(D)	2.1
1 – Air Content was Not Measured in Mixes Not Appearing in Table	

Table C-4: Slump and Spread Measured in Concrete Mixtures

Concrete Mixture	Test Executed	Slump (inches)	Spread (inches)
1	slump	2.3	–
2	slump	≥ 9*	–
3	slump	1.6	–
4	slump	1.2	–
5	slump	≥ 9	–
6	slump	≥ 9	–
6	spread	–	20.3
6	slump	0.3	–
6	slump	0.8	–
7	slump	≥ 9	–
7-A	slump	≥ 9	–
8	slump	≥ 9	–
9	slump	≥ 9	–
10	slump	≥ 9	–
11	slump	≥ 9	–
11-C	slump	9.0	–
12	slump	≥ 9	–
13	slump	1.0	–
14	spread	–	28.0
14	slump	0.0	–
14	slump	1.0	–
14	slump	0.5	–
14	slump	5.0	–
14	spread	–	31.0
14-A	spread	–	30.5
14-A	spread	–	27.5
14-A	spread	–	21.0

\*  $\geq 9$  Indicates that the concrete was too flowable to measure a slump reading

Table C-5: Slump and Spread Measured in Concrete Mixtures (Cont.)

Concrete Mixture	Test Executed	Slump (inches)	Spread (inches)
15	slump	4.0	–
15	slump	0.8	–
15	slump	0.8	–
16	slump	1.0	–
16	slump	1.3	–
17	slump	4.5	–
17	slump	0.5	–
17	slump	0.8	–
18	slump	0.8	–
18	slump	0.5	–
6-HD	spread	–	20.8
6-HD	spread	–	17.3
6-HD	spread	–	19.3
6-HD	slump	4.8	–
6-HD	spread	–	18.0
6-HD	slump	7.5	–
6-HD	slump	2.5	–
15-HD	slump	4.0	–
15-HD	spread	–	16.0
15-HD	spread	–	20.5
15-HD	spread	–	18.0
15-HD	spread	–	30.0
15-HD	spread	–	15.8



## APPENDIX D

### RECOMMENDED CONCRETE MIXTURE DESIGN SPECIFICATION

The following recommendations and specifications are only to be used as a guide. Trial batches need to be developed based on availability of materials near the site. Table D-1 provides recommendations on the types of materials to use in the development of accelerated bridge construction (ABC) closure pour concrete mixtures. The quantities included in this table are recommended to be used as initial estimates for concrete mixture design when developing the mixture through trial batches.

A specification recommending performance requirements for high-early strength concrete mixtures that can be used in closure pours for accelerated bridge construction is provided in Table D-2. The recommended ranges are provided for relevant concrete properties that were tested for this project. Additional testing, outside the scope of tests shown in Table D-2, should also be performed to fully understand the behavior of the concrete mixtures.

It is recommended that the concrete mixtures used for ABC closure pours be mixed in a concrete mixer onsite. The concrete mixer should be cleaned to minimize the amount of residue that adheres to the walls of the mixer barrel. The concrete mixer barrel should also be dampened prior to each concrete mixture to reduce the amount of water absorbed by residue that may still exist on the walls of the barrel. It is recommended that mixture constituents be added into the concrete mixer in the following order: coarse and fine aggregates, cementitious materials, 75% of water, 25% of water combined with high-range water reducer chemical admixture. ASTM

Standard C192, Section 7.1.2 should be used as a guide for the duration of mixing times and the procedures followed once all concrete constituents have been added to the concrete mixer.

Table D-1: ABC Closure Pour Concrete Mix Design Recommendations

<b>Accelerated Bridge Construction Closure Pour Concrete Mix Design</b>		
Materials		
Material		Recommended
Cement	-	ASTM Type III Portland Cement <sup>1</sup>
Cementitious Material	Fly ash	Class F
Chemical admixtures	High-Range Water Reducer	WR Grace ADVA CAST 575 or Similar
Aggregates	Coarse Aggregate Size	1/2" Coarse Aggregate
	Aggregate Shape	Angular/Elongated/Flat
	Aggregate Texture	Rough
Proportions/Quantities		
Parameter		Recommended Value
Aggregates	Aggregate Gradation	Maximum Compaction Using Fuller-Thompson Curves
Cement Content	W/CM Ratio	0.29 by Mass
Paste Content	$V_{\text{paste}}/V_{\text{voids}}$	1.75 by Volume
Cementitious Materials	Fly Ash Replacement	15% of Cement by Mass
Chemical Admixtures	High-Range Water Reducer	16 oz./cwt of Cementitious Materials <sup>2</sup>
1 – High-Early Strength		
2 - 33% More Than Max. Typically Recommended by Manufacturer		

Table D-2: ABC Closure Pour Concrete Specifications

<b>Accelerated Bridge Construction Closure Pour Concrete Specifications</b>				
<b>Strength</b>				
Specification	Property		Acceptable Values	Units
ASTM C39	Compressive Strength	12 Hours of Curing	$\geq 3500$	PSI
		24 Hours of Curing	$\geq 7000$	
		28 Days of Curing	$\geq 10000$	
<b>Constructability</b>				
Specification	Property		Acceptable Values	Units
ASTM C403	Set Time	Initial Set	3 - 6	Hours
		Final Set	5 - 8	
ASTM C143	Consistency	Slump	$\geq 4$	Inches
ASTM C1611		Spread	$\leq 30$	
<b>Durability/Serviceability</b>				
Specification	Property		Acceptable Values	Units
AASHTO PP 34-99	Confined Shrinkage	Time to Cracking	$\geq 14$	Days
ASTM A944	Concrete-Reinforcement Bond Strength	Maximum Load Reached	$\geq$ Nominal Yield Strength of Test Bar	Kip
ASTM C1567	Alkali-Silica Reactivity	Percent Length Extension	$\leq 0.10\%$ Extension	%